Chapter 21

Printing

(Revision 2, Aug 2007)

The Model 4040 Viper Analyzer allows you to print jobs, setups, and graphic spectra.

The “Print” option is available through the various analyzer functions mentioned above as a selection from the “Manage Job” submenus of these functions. See the chapters for the individual functions for specifics on how to access the print function within each.

Before printing for the first time to a printer, you must first input the printer’s specifics into the analyzer’s memory using the “Setup Printer” function as described in the following section, 21.2. Once a specific printer is “setup” you do not have to repeat this step each time you print to that printer. Before printing you must also physically connect the analyzer and printer with cables, connectors, etc. as needed for that specific printer. This process is described in section 21.3. The process of selecting and accessing the “Print” function from the analyzer is described in section 21.4.

21.1. – Supported Printers

The Viper 4040 analyzer supports direct printing to the following SERIAL PRINTERS: Epson-compatible dot-matrix printers, Hewlett-Packard Laser Jet II or higher versions of Laser Jet printers, and Seiko DPU-414 thermal printers. (See your specific printer manual for Epson compatibility information.)

The analyzer supports only the three listed printer types with its *direct serial* output. However, the analyzer also supports printing to parallel printers with the use of a serial-to-parallel print converter. The converter can be purchased from ACES Systems or from your local electronics dealer. ACES Systems does not provide technical support for difficulties in printing associated with printer converters not purchased through ACES Systems since there are so many converters available for which we have no technical information.

The communications/printer cable provided with the analyzer is a serial communications cable for transfer of data to a personal computer, serial printer, or serial-to-parallel converter. If using a parallel printer, you will also need a standard printer cable (purchase locally) configured for connection of the converter to your parallel printer.

21.2. - Printer Data Setup

Before printing from the analyzer to a specific printer for the first time, you must first enter data specific to the printer type into the analyzer's memory through the "Setup Printers" function. This function is accessed through the "Miscellaneous Items" option on the "Main Menu" (see illustrations below). Once a specific printer is "setup," you do not have to perform the "Printer Setup" process each time you print to that printer.

The "Setup Printer" option allows you to select from three possible printer types (discussed in the previous section, 21.1), three print qualities, horizontal and vertical page margins, and paper size.

Print quality is largely determined by the visual quality of spectral graphics and print desired by the user. The higher quality print takes longer for the dot matrix printer to perform. Experiment with the three quality options to determine which best fits your needs.

To complete the "Setup Printer" process, do the following:

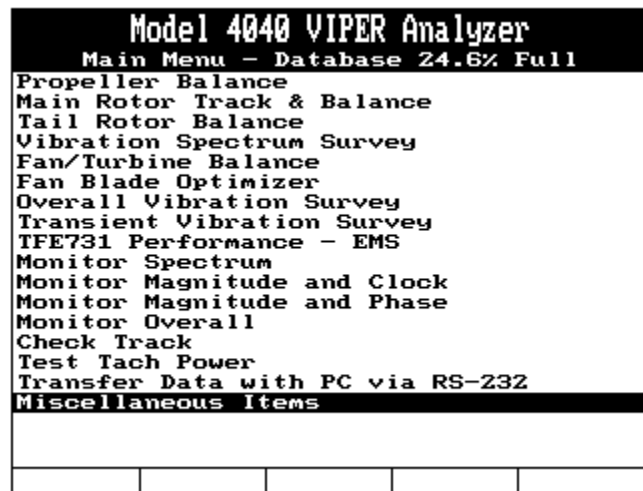

1. Select "Miscellaneous Items" from the Main Menu banner screen.
2. Select "Setup Printers" from the "Miscellaneous Items" banner screen menu. The "Setup Printer" banner screen shown below appears.

```

Model 4040 VIPER Analyzer
Setup Printers

Printer: LaserJet (Laser)
Quality: Low (Fastest)

Page Margins:
Sides: 1.0
Top/Bottom: 1.0

Page Size:
Width: 8.5
Length: 11.0

```

3. Use the [⇒] key to toggle between the three printer choices in the “Printer” field to select a printer. (Refer to Chapter 3, “Using the Viper 4040 Viper” if you are unfamiliar with using the keypad or the toggle function.)
4. Use the [↓] key to move down to the next field, “Quality.” Select print quality by using the [⇒] key to toggle between the choices.
5. Use the [↓] key to move down to the next field, “Pg Margin, Horiz” Enter the desired margin size using the keypad. Use the [↓] key to move to the next field in this area of the screen. Enter all dimensions in the four fields in this part of the screen using the keypad.
6. Press [ENTER] to accept your settings and exit the screen.

Proceed to the next section to configure printer equipment (cables, connectors, etc.) for printing.

21.3. – Printer Equipment Setup

There are four possible printer equipment configurations for printing with the Viper 4040. Each configuration is described in the following sections.

21.3.1. - Print to a Serial Printer

21.3.1.1. – Equipment Required

1. Serial Printer, Epson FX Compatible/Hewlett Packard LaserJet II or newer/Seiko DPU 414
2. Model 4040 Viper Analyzer
3. Serial/Communication Cable (PN10-320-0157)
4. Adapter (Gender Changer) (PN75-900-0201)

21.3.1.2. – Equipment Setup

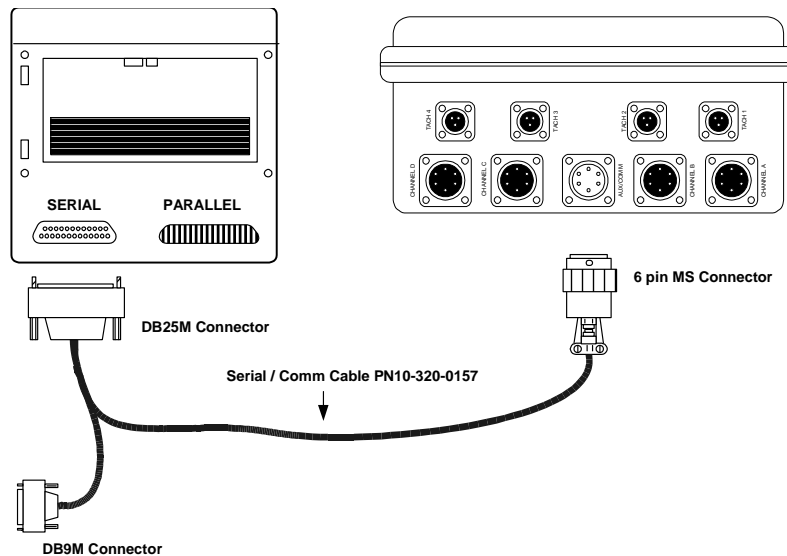

**Configuration 1; Print to Serial
W / DB25M Connector**

To setup the equipment for this printing configuration, refer to the illustration above and do the following:

1. Connect the Serial/Communication Printer Cable 6 Pin MS Connection to the Viper 4040
2. Connect the other end of the Serial/Communication Printer Cable DB9 Connector to the 9-Pin Null Modem Adapter
3. Connect the Null Modem Adapter to the DB9 Pin port on the Printer.

You are ready to print. See section 21.4 to continue with the printing process.

21.3.3. - Print to a Parallel Printer with Internally-Powered Converter

21.3.3.1. - Equipment Required

1. Parallel Printer; HP LaserJet II or newer (higher) version of LaserJet printer/Epson FX/Seiko DPU 414
2. Viper 4040 Analyzer
3. Interface Cable (535) (PN 10-320-0201)
4. ACES Systems' Model 535 S-P Converter (PN 10-100-0535)
5. Standard DB25M-Centronix Printer Cable (purchase locally)

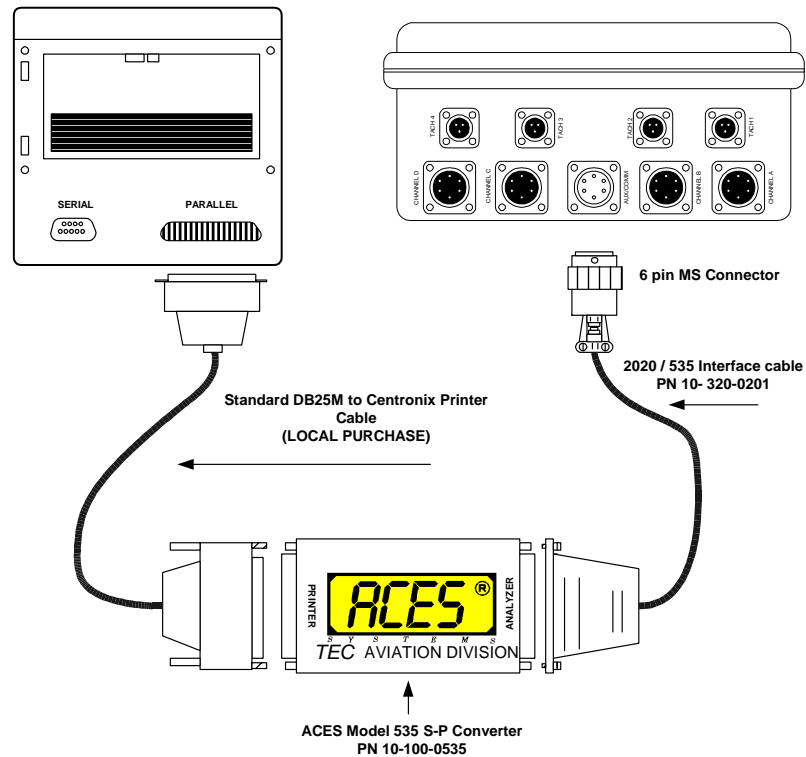
21.3.3.2. - Equipment Setup**Configuration 3; Print to Parallel
W / Converter**

To setup the equipment for this printing configuration, refer to the illustration above and do the following:

1. Connect the 6 Pin MS connector of the Interface Cable (535) (PN10-320-0201) to the 6-Pin, AUX/COM port of the Model 4040.
2. Connect the DB25 connector end of the Interface cable to the “Analyzer” port of the ACES Systems’ Model 535 S-P Converter (PN10-100-0535)
3. At the “Printer” end of the ACES Systems’ 535 Converter, attach the Standard DB25M to Centronix cable (purchase locally)
4. Connect the Centronix connection to the Centronix connection on the Printer.

You are ready to print. See section 21.4 to continue with the printing process.

21.3.4. - Print to a Parallel Printer with Externally-Powered Converter

21.3.4.1. - Equipment Required

1. Parallel Printer, HP LaserJet II or newer (higher) version of LaserJet printer
2. Viper 4040 Analyzer
3. Serial/Communication Printer Cable (PN10-320-0157)
4. Adapter (gender changer) (PN75-900-0201)
5. SXP 1000 bi-directional (Powered) Converter (PN75-210 0056)
6. Standard Centronix to Centronix Cable (purchase locally)

21.3.4.2. - Equipment Setup

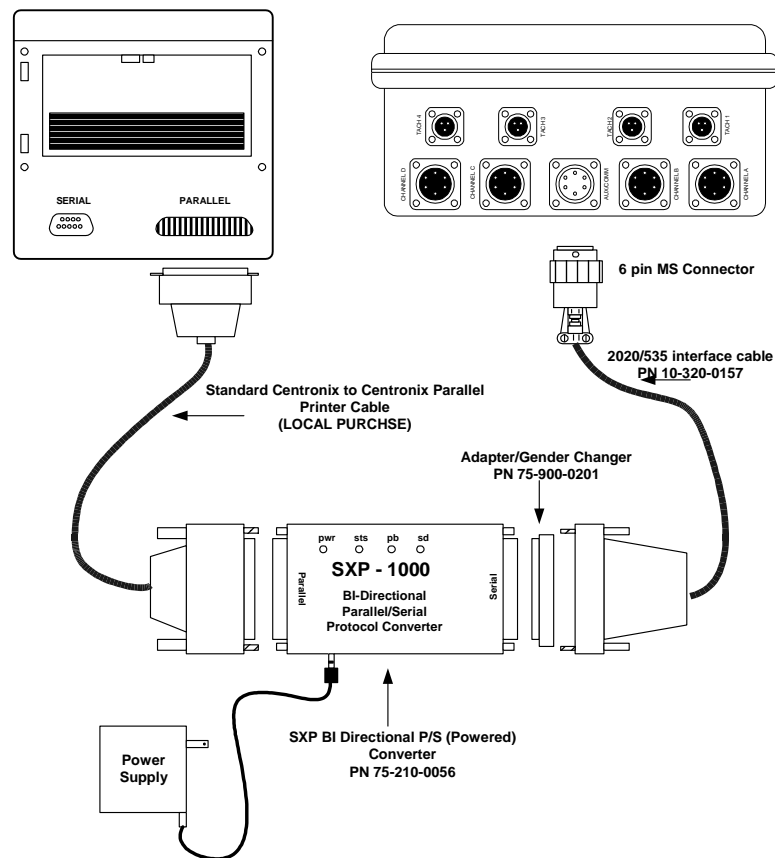

**Configuration 4; Print to Parallel
W / External Powered
Converter**

To setup the equipment for this printing configuration, refer to the illustration above and do the following:

1. Connect the 6-Pin MS connector of the Serial/Communication Printer Cable (PN10-320-0157) to the AUX/COM port on the Model 4040
2. Connect the other end of the Serial/Communication Printer Cable DB25 Connector to the Adapter (Gender Changer) (PN75-900-0201)
3. Connect the Adapter to the DB25 connector on the SXP 1000 Converter (PN75-210-0056)
4. Connect the Standard Centronix Printer Cable to the SXP 1000 Converter and the other end to the Centronix connection on the printer.

NOTE

For this configuration, the DIPswitches on the SXP1000 must be set as follows: 1,3,7,8,9&10 OFF. 2,4,5&6 ON. "DTE" must also be selected. The DIP switches and DTE switches are located on the side of the converter adjacent to the external power cord port.

You are ready to print. See section 21.4 to continue with the printing process.

21.4. – Print

To print a propeller balance job, rotor track and balance job, job setup, or graphic spectra, do the following:

1. Turn the printer on and ensure you have sufficient paper loaded for the print job.
2. From the analyzer's Main Menu banner screen, select the procedure you intend to print from, such as "Propeller Balance" (as shown in this example), "Tail Rotor Balance" or "Vibration Spectrum Surveys." The print function is available from any of the "Main Menu" "Job" functions. The print function is not available from the "Main Menu" "Monitor" or "Check" functions.

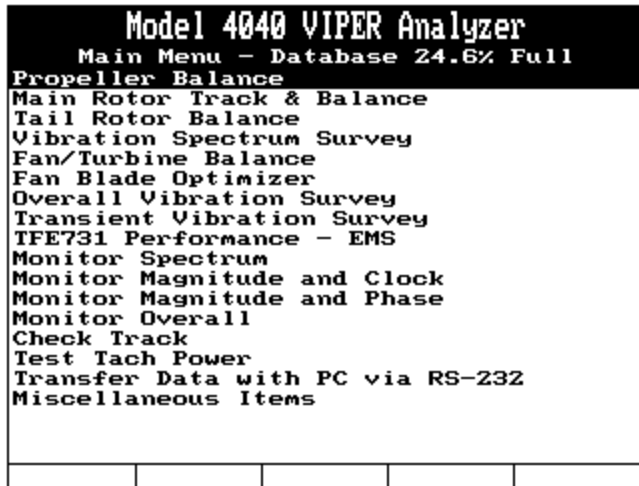

3. Select "Manage Jobs" or "Manage Setups".

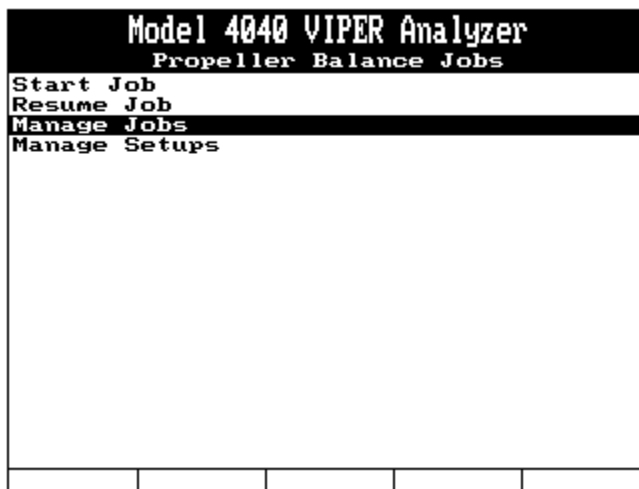

4. From the "Manage Jobs" or "Manage Setups" menu, select "Print".

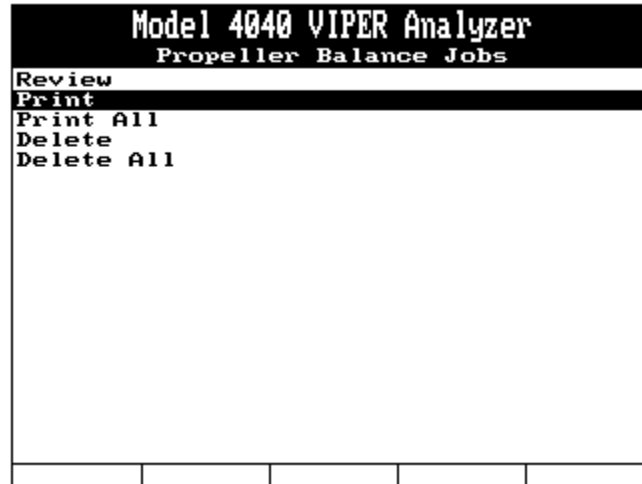

5. Select the job/setup you want to print.
6. Press [ENTER] to print.

The analyzer screen will display the message "Printing in Progress," and when all data has been transferred from the analyzer to the printer's print buffer, the analyzer will display the message "Successful Print."

If the print job was not successful, recheck the printer for possible problems. Examples of problems include inadequate paper quantity, paper jam, pauses, printer not turned on, improper connection of the cable, improper converter, and the wrong printer is selected on analyzer printer setup, incompatible baud rate selection, or loss of power. Check these potential problem areas, and then try to print again. If the print function still does not work, call ACES Systems' Customer Support at the phone number listed at the front of the manual.