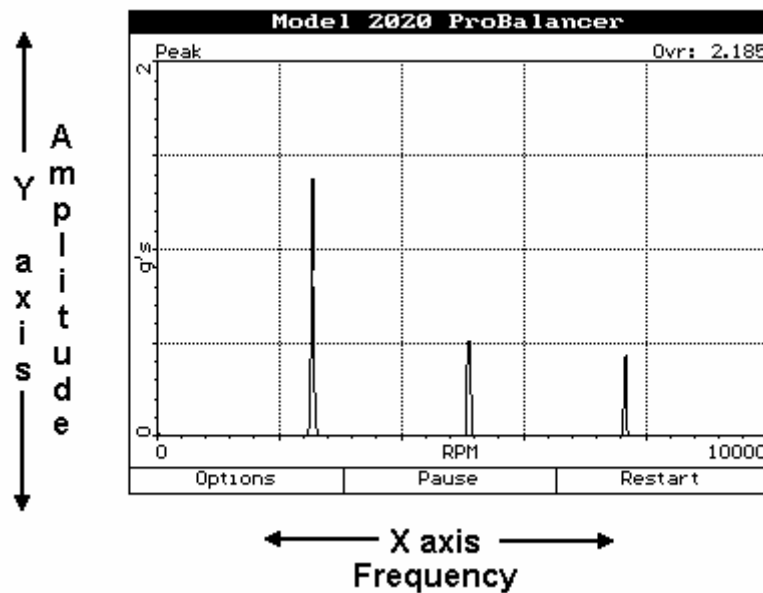

Chapter 16

Reading Spectrum and Scales

(Revision 2, February 2005)

The information in this chapter is provided to assist you in reading the graphical displays of the various types of data that can be acquired using the Model 2020 ProBalancer Analyzer.

16.1 - Reading the X and Y Plotted Vibration Spectrum



A graphic spectrum display allows the user to investigate all aspects of a rotating component related to vibration. In the figure above, the primary indicators are the plotted peaks that represent component vibrations.

The scale of the “X” axis, along the lower horizontal edge, displays the frequency of interest in Hertz (Hz), which is cycles per second, or in Revolutions per minute (RPM), as shown in the figure. The frequency scale is a means of locating a component operating at a known number of cycles per second (Hz) or minute (RPM).

The scale of the “Y” axis, along the left vertical edge, displays the amplitude or strength of the component’s expended energy in the specified engineering units. In the figure above, the engineering units are presented as IPS, or Inches Per Second, of movement.

16.2 - Reading the Converging Vibration Indicator and Scale

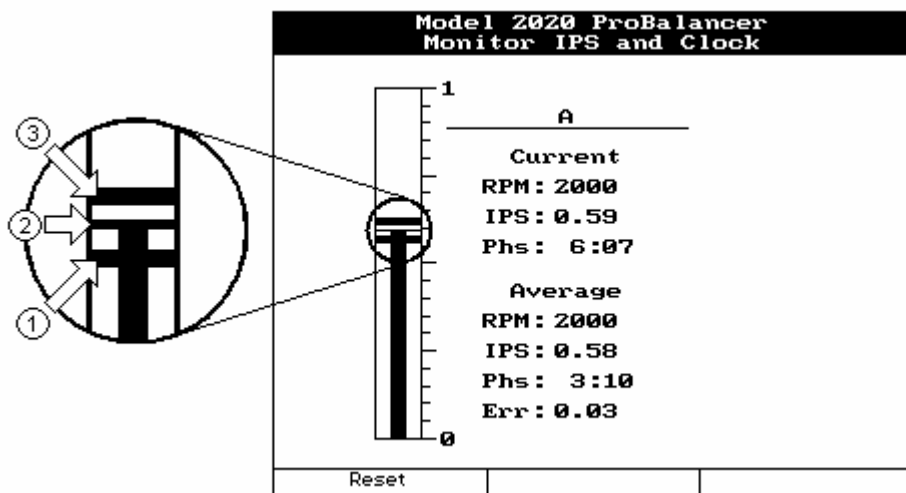

The converging vibration indicator and scale, as shown in the illustration above, appears in several instances when using the analyzer. The Propeller Balance, Main Rotor Track and Balance, Tail Rotor Balance, Monitor Magnitude and Phase, and Monitor IPS and Clock functions all use the converging vibration scale.

The scale is graduated along the right vertical side of the indicator from 0 at the bottom to the upper end of the scale. The vertical indicator bar which begins at the bottom and continues upward in the center of the window indicates the current average. A thin horizontal line (see arrow 2 in the figure above) indicates the latest collected amplitude. The lower error bar (see arrow 1 in the figure above) and the upper error bar (see arrow 3 in the figure above) will converge on the average indicator as errors are averaged out of the indication. Also notice that to the right of the indicator, the error is reported as a numeric value.

When collecting data with this indicator displayed, you should continue taking data until the upper and lower error bars converge on the average indicator. The reported error will also continue to decrease as the bars converge. Allow the unit to collect data as long as the error continues to decrease. This will insure you have the most accurate data possible. If you believe wind gust, aircraft movement or other external influences have caused the indications to be corrupted, press the [F1] key for “Reset.” This will clear the averaged data and begin a new averaging. When satisfied that the data is acceptable, press [ENTER] to stop the data collection and accept the averaging.