Chapter 14

Printing

(Revision 2, February 2005)

The ACES Model 2020 ProBalancer Analyzer allows you to print propeller balance jobs, rotor track and balance jobs, job setups, and graphic spectra.

The “Print” option is available through the various analyzer functions mentioned above as a selection from the “Manage Job” submenus of these functions (shown below in the example banner screen menu for “Propeller Balance”). See the chapters for the individual functions for specifics on how to access the print function within each.

| Model 2020 ProBalancer Main Menu | | |
|-------------------------------------|---------|-----------|
| Propeller Balance | | |
| Main Rotor Track & Balance | | |
| Tail Rotor Balance | | |
| Vibration Spectrum Surveys | | |
| Monitor Spectrum | | |
| Monitor IPS and Clock | | |
| Monitor Magnitude and Phase | | |
| Monitor Overall Vibration | | |
| Check Track | | |
| Transfer Data with PC | | |
| Miscellaneous Items | | |
| -Contrast | Default | +Contrast |

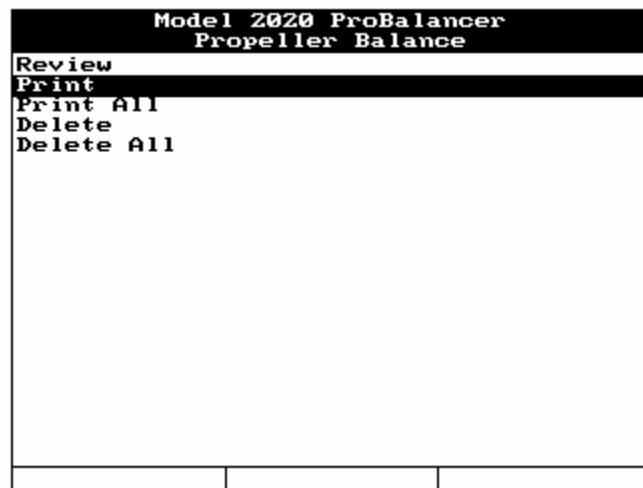
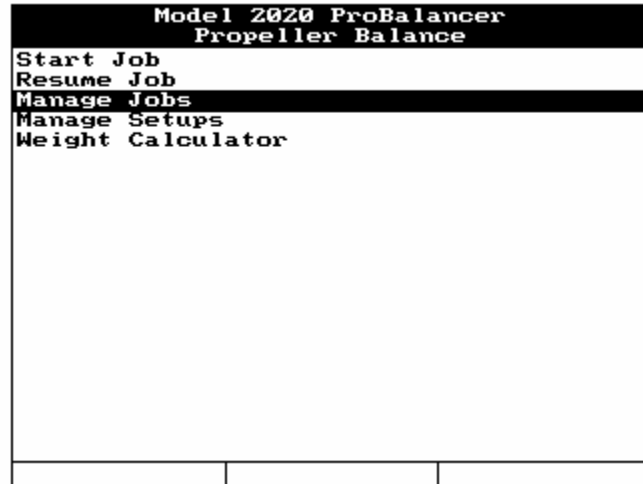

Before printing for the first time to a printer, you must first input the printer’s specifics into the analyzer’s memory using the “Printer Data Setup” function as described in the following section, 14.2. Once a specific printer is “setup” you do not have to repeat this step each time you print to that printer. Before printing you must also physically attach the analyzer and printer with cables, connectors, etc. as needed for that specific printer. This process is described in section 14.3. The process of selecting and accessing the “Print” function from the analyzer is described in section 14.4.

14.1 – Supported Printers

The ACES Model 2020 ProBalancer Analyzer supports direct printing to Epson-compatible dot matrix printers, Hewlett-Packard Laser Jet II or higher versions of Laser Jet printers, and Seiko DPU-414 thermal printers. (See your specific printer manual for Epson compatibility information.)

The analyzer supports only the three listed printer types with its *direct serial* output. However, the analyzer also supports printing to parallel printers but a serial-to-parallel print

converter is required to accomplish this. The converter can be purchased from ACES Systems or from your local electronics dealer. ACES Systems does not provide technical support for difficulties in printing associated with printer converters not purchased through ACES Systems since there are so many converters available for which we have no technical information.

The communications/printer cable provided with the analyzer is a serial communications cable for transfer of data to a personal computer, serial printer, or serial-to-parallel converter. If using a parallel printer, you will also need a standard printer cable (purchase locally) configured for connection of the converter to your parallel printer.

14.2 - Printer Data Setup

Before printing from the analyzer to a specific printer for the first time, you must first enter data specific to the printer type into the analyzer's memory through the "Setup Printers" function. This function is accessed through the Miscellaneous Items option on the Main Menu (see illustrations below). Once a specific printer is "setup," you do not have to perform the "Printer Setup" process each time you print to that printer.

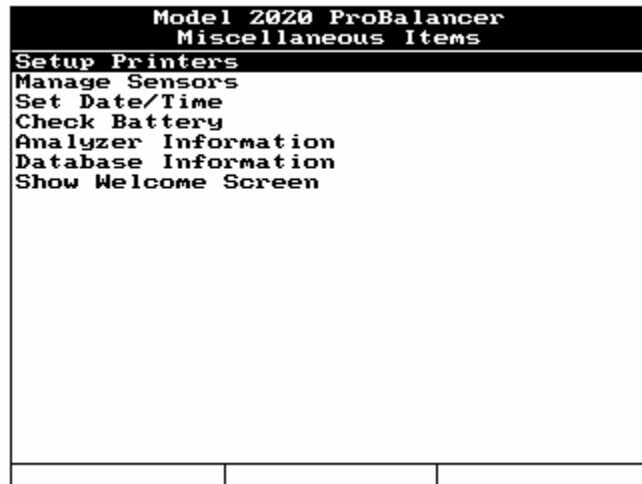
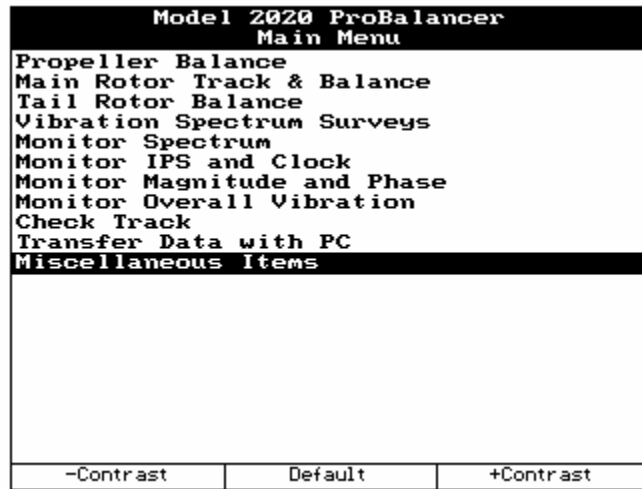

The “Setup Printer” option allows you to select from three possible printer types (discussed in the previous section, 14.1), three print qualities, horizontal and vertical page margins, and paper size.

Print quality is largely determined by the visual quality of spectral graphics and print desired by the user. The higher quality print takes longer for the dot matrix printer to perform. Experiment with the three quality options to determine which best fits your needs.

To complete the “Setup Printer” process, do the following:

1. Select “Miscellaneous Items” from the Main Menu banner screen.
2. Select “Setup Printers” from the “Miscellaneous Items” banner screen menu. The “Setup Printer” banner screen shown below appears.

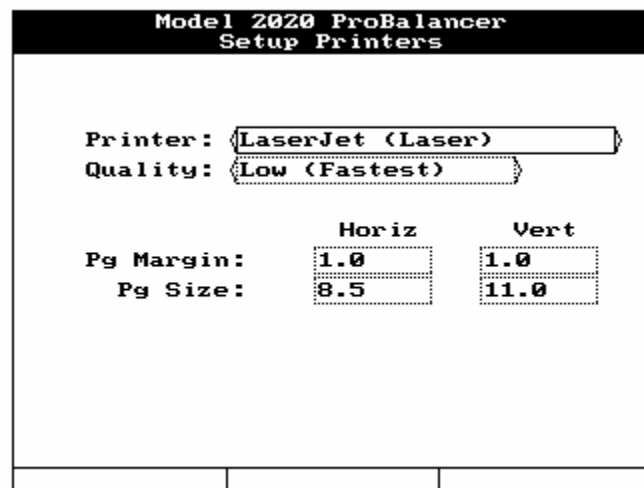

The screenshot shows the "Model 2020 ProBalancer Setup Printers" screen. It features a title bar at the top with the text "Model 2020 ProBalancer Setup Printers". Below the title bar, there are several fields for configuration. The "Printer" field is set to "LaserJet (Laser)", and the "Quality" field is set to "Low (Fastest)". Below these, there are two columns of fields: "Pg Margin" and "Pg Size". The "Pg Margin" field is set to "1.0", and the "Pg Size" field is set to "8.5". To the right of these fields, there are two columns labeled "Horiz" and "Vert". The "Horiz" field is set to "1.0", and the "Vert" field is set to "11.0". The fields are arranged in a grid-like structure with dashed borders.

3. Use the [⇒] key to toggle between the three printer choices in the “Printer” field to select a printer. The three selections have default values entered for “Pg Margin” and “Pg Size”. These values can be edited as necessary by following the steps below. (Refer to Chapter 3, “Using the ACES Model 2020 ProBalancer Analyzer” if you are unfamiliar with using the keypad or the toggle function.)
4. Use the [↓] key to move down to the next field, “Quality.” Select print quality by using the [⇒] key to toggle between the choices.
5. Use the [↓] key to move down to the next field, “Pg Margin, Horiz”. Enter the desired margin size using the keypad. Use the [↓] key to move to the next field in this area of the screen. Enter all dimensions in the four fields in this part of the screen using the keypad. The “Pg Margin” and “Pg Size” fields are fixed for the DPU-414 printer selection, editing is unnecessary.
6. Press [ENTER] to accept your settings and exit the screen.

Proceed to the next section to configure printer equipment (cables, connectors, etc.) for printing.

14.3 – Printer Equipment Setup

There are four possible printer equipment configurations for printing with the ACES Model 2020 ProBalancer Analyzer. Each configuration is described in the following sections.

14.3.1 - Print to a Serial Printer with DB25M Connector

14.3.1.1 – Equipment Required

1. Serial Printer, Epson FX Compatible/Hewlett Packard LaserJet II or newer/ Seiko DPU 414
2. ACES Model 2020 ProBalancer Analyzer
3. Serial/Communication Cable (PN10-320-0157)
4. Adapter (Gender Changer) (PN75-900-0201)

14.3.1.2 - Equipment Setup

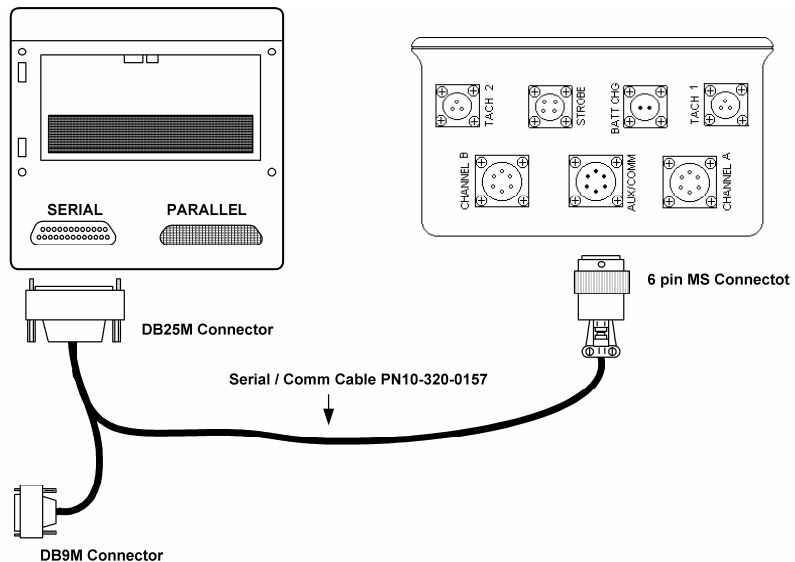

**Configuration 1; Print to Serial
W / DB25M Connector**

To setup the equipment for this printing configuration, refer to the illustration above and do the following:

1. Connect the 6 Pin connector on the Serial/Communication Cable (PN10-320-0157) to the ACES Model 2020 ProBalancer Analyzer's AUX/COM Port
2. Connect the other end of the Serial/Communication cable (DB25 Connector) to the Adapter (Gender Changer) (PN 75-900-0201)
3. Plug the Adapter into the serial port on the printer

You are ready to print. See section 14.4 to continue with the printing process.

14.3.2 - Print to a Serial Printer with DB9M Connector

14.3.2.1 - Equipment Required

1. Serial Printer, HP LaserJet II or newer (higher) version of LaserJet printer/Epson FX/Seiko DPU 414
2. ACES Model 2020 ProBalancer Analyzer
3. Serial/Communication Printer Cable (PN10-320-0157)
4. 9-Pin Null Modem Adapter (PN75-900-0226)

14.3.2.2 - Equipment Setup

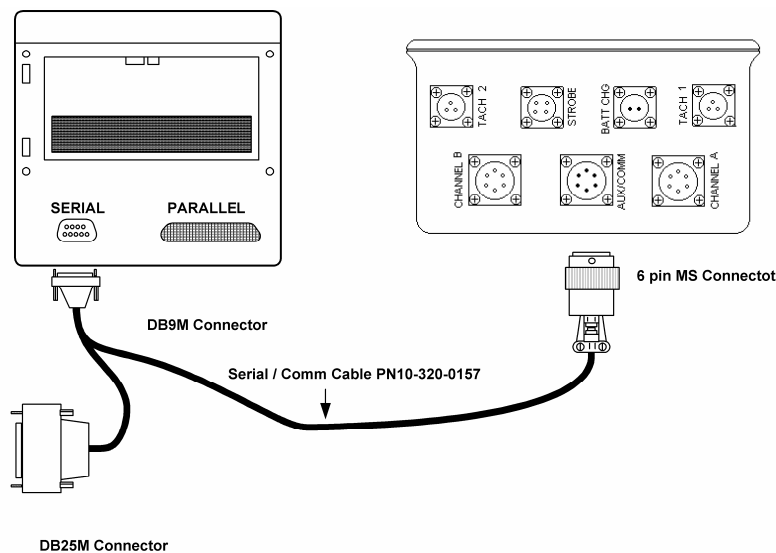

**Configuration 2; Print to Serial
W / DB9M Connector**

To setup the equipment for this printing configuration, refer to the illustration above and do the following:

1. Connect the Serial/Communication Printer Cable 6 Pin MS Connection to the ACES Model 2020 ProBalancer Analyzer
2. Connect the other end of the Serial/Communication Printer Cable DB9 Connector to the 9-Pin Null Modem Adapter
3. Connect the Null Modem Adapter to the DB9 Pin port on the Printer.

You are ready to print. See section 14.4 to continue with the printing process.

14.3.3 - Print to a Parallel Printer with Converter

14.3.3.1 - Equipment Required

1. Parallel Printer; HP LaserJet II or newer (higher) version of LaserJet printer/Epson FX/Seiko DPU 414
2. ACES Model 2020 ProBalancer Analyzer
3. Interface Cable (535) (PN 10-320-0201)
4. ACES Systems' Model 535 S-P Converter (PN10-100-0535)
5. Standard DB25M-Centronix Printer Cable (purchase locally)

14.3.3.2 - Equipment Setup

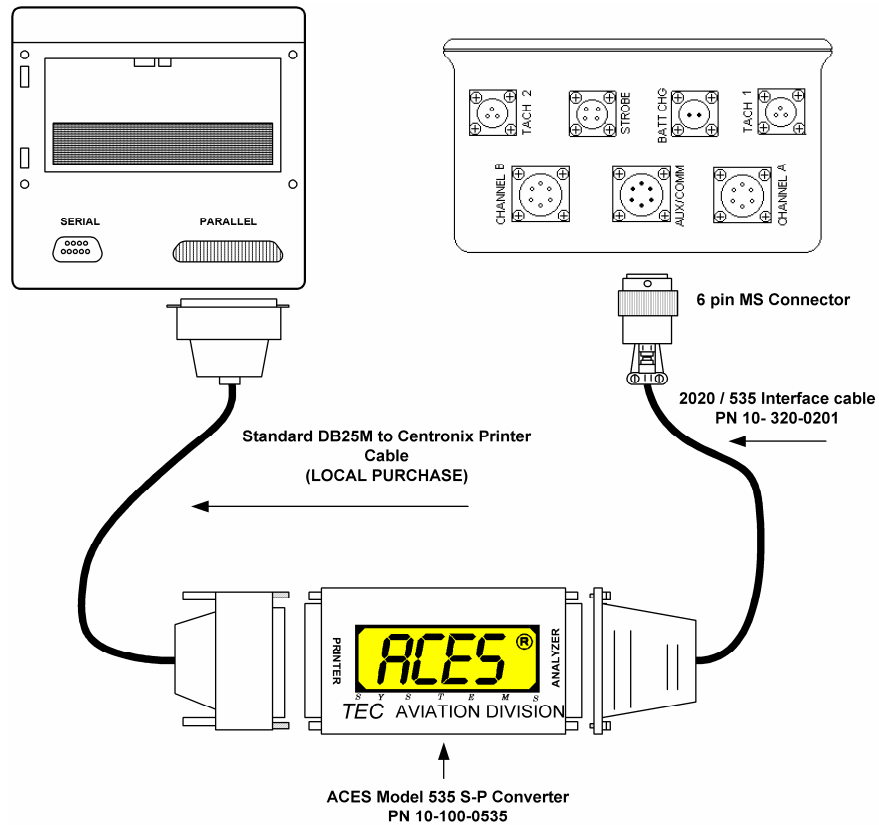

Configuration 3; Print to Parallel W / Converter

To setup the equipment for this printing configuration, refer to the illustration above and do the following:

1. Connect the 6 Pin MS connector of the Interface Cable (535) (PN10-320-0201) to the 6-Pin, AUX/COM port of the ACES Model 2020 ProBalancer Analyzer.
2. Connect the DB25 connector end of the Interface cable to the “Analyzer” port of the ACES Systems’ Model 535 S-P Converter (PN10-100-0535)
3. At the “Printer” end of the ACES Systems’ 535 Converter, attach the Standard DB25M to Centronix cable (purchase locally)
4. Connect the Centronix connection to the Centronix connection on the Printer.

You are ready to print. See section 14.4 to continue with the printing process.

14.3.4 - Print to a Parallel Printer with Powered Converter

14.3.4.1 - Equipment Required

1. Parallel Printer, HP LaserJet II or newer (higher) version of LaserJet printer
2. ACES Model 2020 ProBalancer Analyzer
3. Serial/Communication Printer Cable (PN10-320-0157)
4. Adapter (gender changer) (PN75-900-0201)
5. SXP 1000 bi-directional (Powered) Converter (PN75-210-0056)
6. Standard Centronix to Centronix Cable (purchase locally)

14.3.4.2 - Equipment Setup

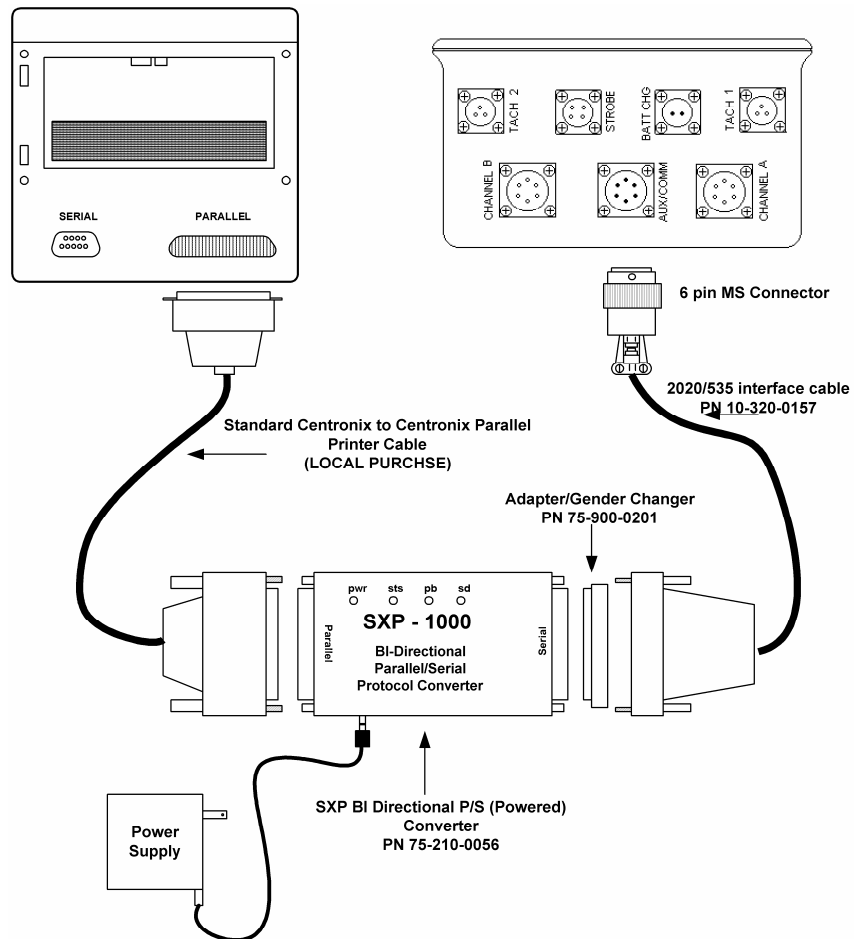

**Configuration 4; Print to Parallel
W / External Powered
Converter**

To setup the equipment for this printing configuration, refer to the illustration above and do the following:

1. Connect the 6-Pin MS connector of the Serial/Communication Printer Cable (PN10-320-0157) to the AUX/COM port on the ACES Model 2020 ProBalancer Analyzer
2. Connect the other end of the Serial/Communication Printer Cable DB25 Connector to the Adapter (Gender Changer) (PN75-900-0201)
3. Connect the Adapter to the DB25 connector on the SXP 1000 Converter (PN75-210-0056)
4. Connect the Standard Centronix Printer Cable to the SXP 1000 Converter and the other end to the Centronix connection on the printer.

NOTE

For this configuration, the DIP switches on the SXP1000 must be set as follows: 1, 3, 7, 8, 9 & 10 OFF. 2, 4, 5 & 6 ON. "DTE" must also be selected. The DIP switches and DTE switches are located on the side of the converter adjacent to the external power cord port.

You are ready to print. See section 14.4 to continue with the printing process.

14.4 – Print

To print a propeller balance job, rotor track and balance job, setup, or graphic spectra, do the following:

1. Turn the printer on and ensure you have sufficient paper loaded for the print job.
2. From the analyzer's Main Menu banner screen, select the procedure you intend to print from, such as "Propeller Balance," "Tail Rotor Balance" or "Vibration Spectrum Surveys."
3. Select "Manage Jobs" or "Manage Setups"
4. From the "Manage Jobs" or "Manage Setups" menu, select "Print"
5. Select the job or setup you want to print.
6. Press "Enter" to print.

The analyzer screen will display the message "Printing in Progress," and when all data has been transferred from the analyzer to the printer's print buffer, the analyzer will display the message "Output to Printer Complete." Press the [F3] "Continue" key to return to the procedure's sub menu.

If the print job was not successful, recheck the printer for possible problems. Examples of problems include inadequate paper quantity, paper jam, pauses, printer not turned on, improper connection of the cable, improper converter, the wrong printer is selected on analyzer printer setup, or loss of power. Check these potential problem areas, then try to print again. If the print function still does not work, call ACES Systems' Customer Support at the phone number listed at the front of the manual.