

Chapter 2

Analyzer Description

(Revision 4, July 2007)

This chapter gives you a brief tour of the ProBalancer. It describes the various keys and their functions, the input and output ports, and the standard accessories supplied with the ProBalancer. Optional accessories are discussed later in the chapter in Section 2.5, Optional Equipment.

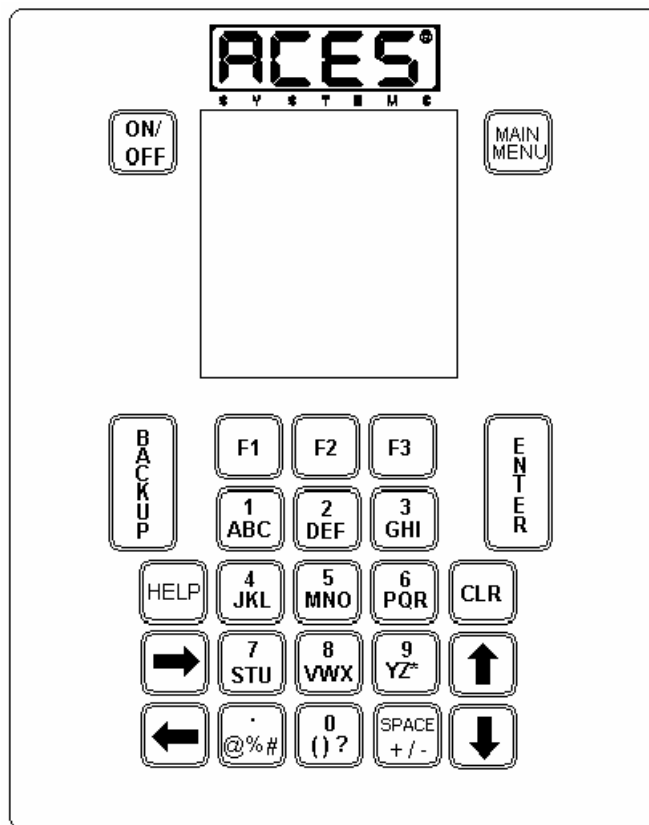

2.1 - Keypad

The ProBalancer keypad consists of 25 function keys. (See Chapter 3, “Using the Model 2015 Balancer” for keypad operation.)



Located at the top left of the ProBalancer keypad, the [ON/OFF] key, when pressed once and released, turns the ProBalancer power on or off. The ProBalancer incorporates a power conservation function. If no activity (keystroke) occurs within ten minutes following the on keystroke, the ProBalancer will automatically shut off. If activity does occur within ten minutes, the ProBalancer remains on for thirty minutes with no activity before automatically shutting off. As long as a keystroke is detected at least once every thirty minutes thereafter, the ProBalancer remains powered until the [ON/OFF] key is pressed to turn power off, or the battery's charge expires.



The [MAIN MENU] key is used as a means to quickly return to the main menu (the first menu that appears when the ProBalancer is powered on) without the necessity of multiple steps. When pressed momentarily then released, this key produces the same action as turning the ProBalancer power off, then back on. The key may be used to escape screens where [BACKUP] will consume too much time for the user. Pressing the [MAIN MENU] key causes all in-progress functions to cease and incomplete balance or survey data to be lost in whole or in part. Holding the [MAIN MENU] key down for more than two seconds will turn the ProBalancer off.

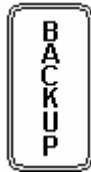

The [BACKUP] key allows the user to back up one step in the current running procedure to make corrections or immediate changes. The [BACKUP] key is also used to escape an active screen where no other options for exit are available. Data may be lost or overwritten when using the [BACKUP] key in certain screens.



Three function keys ([F1], [F2], and [F3]) are located directly below the ProBalancer's screen. Three small rectangular boxes on the screen directly above the keys define their use as it corresponds to each screen. The purpose of each key may change from screen to screen. If any of the screen boxes are blank, the box's corresponding key has no function in that screen.



The [ENTER] key is pressed to accept data or a menu selection and set that selection into motion. The key is used in survey and balance procedures to proceed to the next step.



Pressing the [HELP] key allows you to access guidance and/or examples of information which can be entered into the current field.



The ten alphanumeric keys (0 through 9 / A through ?) are used to input alphanumeric values into the ProBalancer. A single press followed by a two-second delay returns the numeric value (first character) of the key. Two rapid presses followed by a two second delay returns the second character (first of the three alpha characters) of the key. Three or four rapid presses followed by a two-second delay returns the third or fourth (second or third alpha) characters of the key, respectively. For example, if you want to type the letter "N" which is the third character on its corresponding key, press the key three times rapidly, and then stop for two second. The letter "N" should appear on the screen. In order to enter multiple characters found on the same key, press the [=>] to bypass the two second waiting period and progress directly to the next character.



The [CLR] key is used to clear input in the current field.



The four arrow keys (up, down, left, and right) are used to select, move between fields and positions within a field, or highlight menu items on screen. They are also used in various functions to "toggle" between choices, to increase or decrease screen values and graphic display sizes, and to change the field value or cursor position.



The symbols key (.@%&) has multiple functions. The "." is used for placement of a decimal in fractional numbers such as 98.6. The other characters on this key are used as they would be in normal text such as "54 grams @ 230 degrees" or "3% error," or "Left & Right propellers." To type any of the symbols on this key, follow the same procedure described in the preceding paragraph that is used for the alphanumeric keys.



The [SPACE] key has multiple functions also. The characters can be used as normal text in a text field. To type any of the symbols on this key, follow the same procedure described in the preceding paragraphs as used for the alphanumeric keys. The (-) character can be used to represent the removal of weight in a balance solution screen. A single press of this key, while in a weight entry field, will display the (-) character.

2.2 - Screen

The full graphics Liquid Crystal Display (LCD) screen is how the ProBalancer communicates with the user. In computer terminology, the screen is the "graphical user interface." The screen displays messages, menus, selection lists, graphic illustrations, and survey plots. The display is 2.6 inches high by 2.6 inches wide. It is an adjustable-contrast, backlit LCD with a 192 x 192 dot-matrix display. It is capable of displaying 32 columns and 16 lines of text at one time. The backlight is turned on automatically when ProBalancer power is turned on. Screen contrast is controlled by pressing one of the function keys ([F1] for less contrast and [F3] for more contrast) on the main menu screen, which is the first menu screen displayed after the ProBalancer is turned on.

NOTE

If the ProBalancer is exposed to extremes in temperature, either heat or cold, the LCD may darken or lighten to a point that it cannot be clearly read. If this occurs, press the [MAIN MENU] key and adjust the contrast to compensate for the change by pressing the [F1] key for -Contrast or the [F3] key for +Contrast. If this fails to return the LCD to

a viewable state, remove the unit to an ambient room temperature of 65 – 85 degrees F. The LCD should return to its previous state in approximately 30 minutes.

2.3 - Input and Output Ports

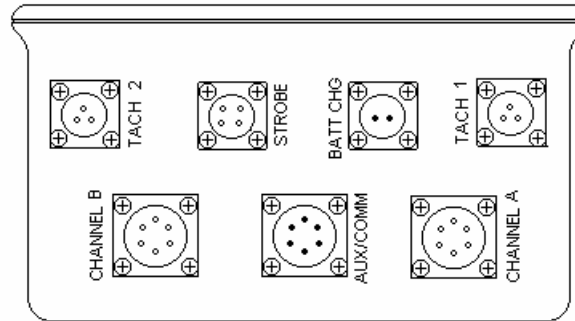

There are seven input/output ports on the end panel of the ProBalancer, as shown in the figure above: two “CHANNEL” (vibration channel) inputs (velocity or acceleration), two “TACH” (tachometer) inputs, one “BATT CHG” (battery charge) input, one “AUX/COMM” (auxiliary/communication) input/output, and one “STROBE” input/output port.

2.3.1 – CHANNEL Ports

The two vibration inputs will accept any of three sensors, the 991V, 991D-1 or CH7310. Both inputs are six-pin MS socket connectors. The default configuration for a two-plane balance on a single engine is “CHANNEL A” for the front sensor and “CHANNEL B” for the rear sensor. These default values can be changed as necessary by the user within the SETUP function. Either of the two channels may be defined as the input for a single plane balance job. The six-pin connector enables the ProBalancer to provide sensor power as required by the sensor being used.

2.3.2 – TACH Ports

The “TACH 1” and “TACH2” inputs are three-pin female receptacle connectors. They will accept either a raw tachometer speed reference signal or a Transistor-Transistor Logic (TTL) level speed signal. Power (+12V) is provided on one pin of the tachometer connector to power optical speed sensors such as the Phototach or LASETACH®.

2.3.3 – BATT CHG Port

The “BATT CHG” (Battery Charge) port is used in conjunction with the battery charger supplied with the ProBalancer. Your ProBalancer will come with either a 110V or 220V charger according to your geographical requirements.

WARNING

When using the 220V battery charger, do not leave the battery attached (on charge) for a period of more than 24 hours. To do so may result in damage to the battery and/or ProBalancer.

WARNING

The protective cap on the “BATT CHG” port must remain in place during periods when the charging unit is not connected. The two pins of the charging input are active at all times and may be shorted by unintentional contact with a conductor if the cap is not in place.

2.3.4 – AUX/COMM Port

The “AUX/COMM” or Auxiliary and Communications port is a 6-pin MS type male connection used for serial communications between the ProBalancer and a personal computer or modem. The port is also used as a serial printer port. With an optional serial-to-parallel converter, the port may also be used for printing to a parallel printer. Additionally, this port is used to connect an ACES Systems’ Optical Tracker.

2.3.5 – STROBE Port

The “STROBE” port is for connection of a strobe light for manual, visual tracking of rotor or propeller blades. The ProBalancer provides a trigger for the strobe through this port. Power (28V DC) for the strobe must be provided from outside the ProBalancer, usually from a ship’s power source. The strobe and necessary cables are available as optional equipment from ACES Systems.

2.4 - Standard Equipment

When you purchase a Model 2015 ProBalancer, several accessories come with the analyzer as standard equipment. These items are described in the following paragraphs.

2.4.1 - Battery

The primary power source for the ProBalancer is its internal battery. It is a camcorder, RB-85 type 12-volt lead acid battery rated at 2.3 Amp hours. This means that a fully charged battery will supply power at the rate of 2.3 Amps for one hour or at the rate of 1 Amp for 2.3 hours. Typically, a fully charged battery will provide power for 8 hours of continuous operation while powering all four available sensors. Power is proportionally increased with the use of fewer sensors and accessories. A minimum of 2 hours charging time is required for a full charge. As with any lead acid battery, age, usage, and environmental conditions may eventually necessitate battery replacement. We do not recommend you change the battery yourself because of the possibility of damage to other components. Contact ACES Systems for details about return and replacement of the internal battery.

NOTE

The battery must always be stored in a charged state. Leaving the battery in a discharged condition during storage causes sulfation, a condition that makes the battery difficult, if not impossible, to recharge.

2.4.2 - Battery Charger

The ProBalancer's internal battery must be charged periodically. This is accomplished using the battery charger included as standard equipment with your ProBalancer and shown in the figure below (or similar). The 12-Volt DC battery charger is a standard float-type charger commonly used to charge lead-acid, camcorder-type, batteries. The charger has an input of 120VAC, 60Hz, 16W. The output is 12VDC, 800mA. The charger has a three-prong (grounded) outlet connector built into the charging unit which plugs directly into a wall outlet. On some chargers, a red LED indicator light (not shown in the figure below) built into the charger head indicates when a charge is being supplied. The cord is a standard, 16-gage electrical appliance cord that is 6 feet long. The connector is an MS, two-pin female, quarter turn lock type constructed of aluminum alloy and coated with olive drab chromate for corrosion protection.

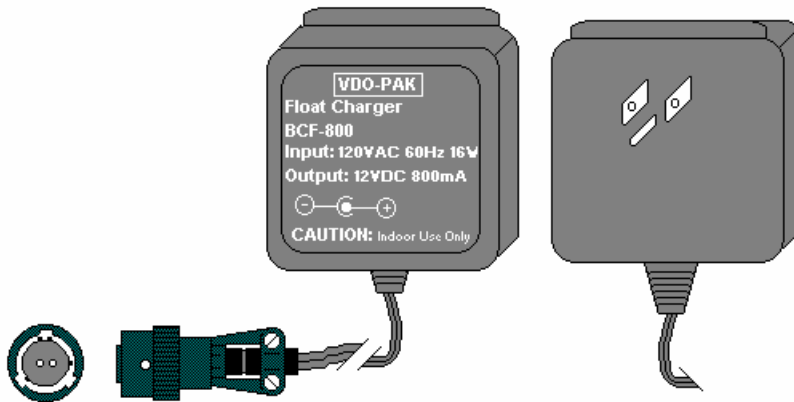
**2.4.2.1 - Charging the Battery**

To charge the battery, do the following.

1. Place the ProBalancer near an indoor AC electrical outlet where it can remain undisturbed for at least two hours.

WARNING

When using the 220V battery charger, do not leave the battery attached (on charge) for a period of more than 24 hours. To do so may result in damage to the battery and/or ProBalancer.

2. Remove the protective cap from the "BATT CHG" port of the ProBalancer and connect the MS connector of the battery charger.

-
3. Plug the charging unit into a 120VAC, 60Hz (or 220VAC 50 Hz for the 220V charger) outlet and note that the red LED indicator light on the charger head illuminates (if so equipped), indicating an in-progress charge.

NOTE

The red LED indicator light does not exist on any 220V chargers or certain models of the 110V charger.

4. Leave the ProBalancer connected to the charger for a minimum of two hours. (The 120V charger may remain connected continuously without harm to the ProBalancer, battery, or charger.) The red LED indicator light will blink when charge is complete.
5. When charging is complete, unplug the charger from the AC outlet and disconnect from the ProBalancer. Replace the protective cap on the ProBalancer's "BATT CHG" port. Place the charger in a safe place for future use.

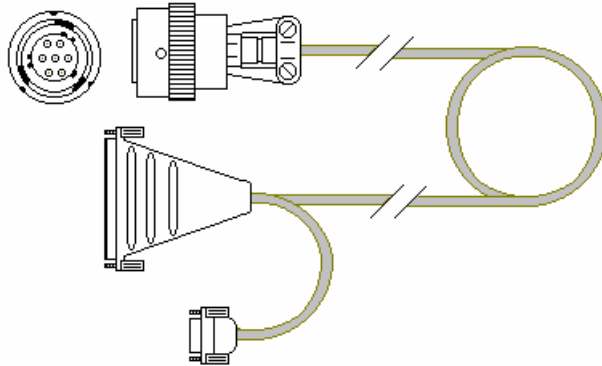

2.4.3 - Communications/Printer Cable

The ProBalancer comes with a communications/printer cable for data transfer with a personal computer or a printer. The cable has both a standard DB25F and a DB9F connector at one end and an MS 6-pin socket connector at the other. This cable is configured to connect directly to your ProBalancer at the 6-pin "COMM" port at one end and to a standard DB25M or DB9M pin for connection to a printer, computer, or interface.

Once connected to a personal computer, you can transfer data to and from the ProBalancer for use with ACES Comm or ACES WinFlash or the optional *AvTrend* software available from ACES Systems.

If connecting to a serial printer, you may require the 25-pin gender changer, which comes with your ProBalancer (For further printing instructions, see Chapter 14, "Printing". Once connected to a printer, you can print completed jobs, setups, spectra, etc.

2.4.4 - Carrying Case

The ProBalancer carrying case is constructed of expanded ABS plastic. The case is durable and protects its contents from the elements when closed and latched. Clean the case with a

mild soap solution and coat with an ARMOR ALL® (ARMOR ALL is a registered trademark of the Clorox Company.) type protectant to preserve appearance. The case has a limited lifetime warranty from the original manufacturer. The case is airtight when the purge valve is closed (turned clockwise to its limits). If the case is transported between the varying pressure altitudes, such as those which occur during air travel, the case may be difficult to open due to pressure differential. If there is a pressure differential between the exterior and interior of the case, open the purge valve by turning it counterclockwise. This will allow the pressure to equalize and ease the task of opening the case.

2.4.5 - User Manual

This user manual is current when you receive it with the ProBalancer. To verify that your manual is current, visit our web site at www.acesystems.com or call ACES Systems at the number listed in the front of this manual.

2.5 - Optional Equipment

Because the Model 2015 ProBalancer is so diverse in its capability, many accessories such as helicopter-specific sensor mounts, blade tracking devices and numerous vibration sensors are available for use with it.

For rotary wing applications, contact ACES Systems directly to inquire about available accessories for your particular needs. Because of the diversity of this application, many accessories are available that are too numerous to list concisely in this manual.

Unlike rotary wing applications, most propeller balancing applications use common accessories, so ACES Systems has assembled a propeller balancing kit, described below, which can be purchased with the Model 2015 ProBalancer.

2.5.1 - Propeller Balancing Kit

The propeller balancing kit contains all the necessary items to complete a single-engine, single-plane propeller balance. If your requirements are multiple-plane balance on a single-engine or multiple-engines balancing, additional equipment will be required. The items in the propeller balancing kit are described below.

2.5.1.1 – Manual, *ACES Systems Guide to Propeller Balancing*

The *ACES Systems Guide to Propeller Balancing* provides procedures and practices for completing an FAA-approved propeller balance job in lieu of airframe or propeller manufacturers' written instructions. The guide includes instructions on installing vibration sensors, photo tachometers, and reflective tape; information on selecting the proper trim weights, attaching trial weights, attaching permanent weights; and other hints for simplifying the balance job. The guide does not provide information on using the ProBalancer. Review this user's manual for detailed information on the ProBalancer's operation.

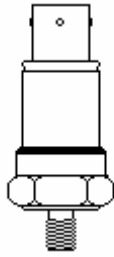

2.5.1.2 - 991D-1 Accelerometer

Although the Model 2015 will support the 991D-1, 991V, and CH7310 vibration sensors, the 991D-1 accelerometer (see the illustration above) was selected as the standard for use with the ProBalancer due to its rugged construction, accuracy, cost, and range of operation. A single sensor is supplied with the propeller balancing kit. Additional sensors can be purchased separately.

The output of the 991D-1 accelerometer is 20 mV per g. The 991D-1 is pre-programmed in the ProBalancer's sensor setup list. The operating temperature range is -50 to + 120 degrees C. The three-pin connector is a MIL-C -26482, and the mating connector is a Bendix PT06-8-3S. The mounting stud is 1/4 x 28. Although the sensor is rugged, it can be damaged when dropped on hard surfaces. Use care when installing the sensor, as you would with other electronic components.



2.5.1.3 - 991D-1 Sensor Cable

The 991D -1 sensor cable, shown above, is a 25-foot (50-foot optional) shielded and Teflon-coated four-conductor cable. The three-pin MS female connector on one end of the cable mates to the 991D -1 sensor. The six-pin MS male connector mates to one of the two (CHANNEL A or CHANNEL B) available vibration-input ports on the ProBalancer. Contact ACES Systems for other sensor, cable, or adapter options.

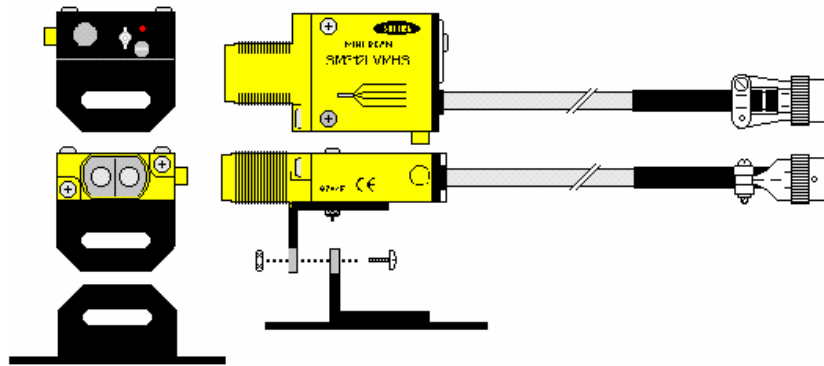

2.5.1.4 - Phototach

The Phototach is a short-range optical sensor used in acquiring speed and phase angle data. Its optimum range is 12 to 18 inches from the target (reflective tape, 3M 7610). It is supplied with a three-inch by three-inch base. An optional camera type swivel mount is available from ACES Systems.

Hardware (screw, nut, and washers) for assembly of the supplied mount is contained in the tackle box which is also supplied with the ProBalancer. The three-pin MS connector attaches directly to the Phototach cable. Other speed/phase sensors that can be used with the ProBalancer can be purchased separately. They include the ACES Systems' LASETACH®, Magnetic Interrupter, or specific-application speed interfaces. Call ACES Systems for further information.



2.5.1.5 - Tachometer Sensor Cable

The tachometer sensor cable connects the ProBalancer to a Phototach, an ACES Systems' LASETACH®, or an interface for optional speed sensors such as a magnetic pickup or pulse generator. The cable is a three-wire shielded cable, insulated in a bright yellow, petroleum-resistant jacket. Attached to one end of the cable is a female three-pin bulkhead type socket connector. On the opposite end of the cable is a male three-pin, quarter-turn-locking MS connector. The connectors are constructed of aluminum alloy with olive drab chromate coated for corrosion resistance. The male end connects to the tach input of any ACES Systems' analyzer/balancer or to the female end of another cable of the same type. The opposite (female, bulkhead) end will accept another 10-320-0126 cable for extension or connect to an aircraft or sensor interface. There is a 50 ft. and a 25 ft. variant of this cable. The 25 ft. cable was built generally for propeller balancing applications which normally require less distance to the sensors. When using this cable to connect to older versions of the Phototach, LASETACH®, or to any other speed-sensing device, an interface appropriate to the application may be required. New-design LASETACHs® with the part number 10-100-

1300 and new-design Phototachs with part number 10-100-1773 have a socket connector that connects directly to the bulkhead connector end of this cable.

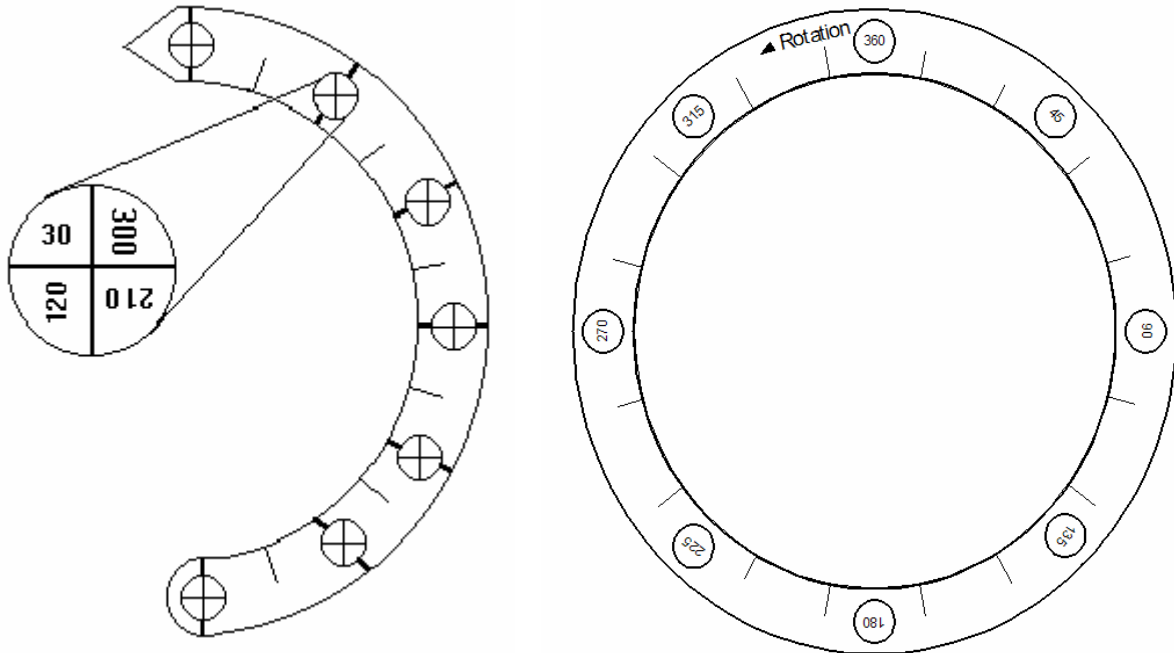

2.5.1.6 - Propeller Protractor

The propeller protractor is designed to measure angles in a typical propeller/spinner assembly. As illustrated in the figure above left, each of the seven circles on the protractor contains four angles. The angle at each circle location can be determined by reading the upright number (for example the 30 degree location in the illustration). The circles are located at 30-degree increments with unmarked 15-degree incremental lines between them. Since the Model 2015 can be configured to calculate solution angles relative to the vibration sensor or reflective tape, both methods are presented here.

The propeller protractor pictured above right is a complete circle. This is divided into five-degree increments. Every 30 degrees, the angle is identified by text. Every 45 degrees, the angle is printed in a circular identifier. Place the propeller protractor over the spinner with the proper direction of rotation side facing you as indicated by the text and an arrow. Since the Model 2015 can be configured to calculate solution angles relative to the vibration sensor or reflective tape, both methods are described in more detail below.

2.5.1.6.1 - Using the Propeller Protractor

For correct use of the protractor when measuring **relative to the vibration sensor**, do the following:

WARNING

Always ensure mag switches are off prior to any movement of the propeller

1. Rotate the propeller with the reflective tape until it is directly in front of the Phototach.
2. With the propeller in this position, place the protractor over the spinner with the pointed end pointing in the direction of rotation (forward looking aft) and one of the 360 degree points aligned with the position of the vibration sensor.
3. Read the upright numbers in the circles, and then interpolate values of the unmarked incremental lines to locate the desired angle.

For correct use of the protractor when measuring **relative to the reflective tape**:

1. Place the protractor over the spinner with the pointed end pointing in the direction of rotation (forward looking aft) and one of the 360 degree points aligned with the position of the reflective tape.
2. Read the upright numbers in the circles, and then interpolate values of the unmarked incremental lines to locate the desired angle.

NOTE

If the angle is out of range for the position of the protractor, rotate the protractor 90 degrees (right or left as appropriate) at a time until you can read the correct angle.

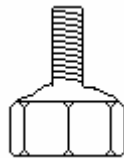
**2.5.1.7 - Case Bolt Adapter Set**

An eight-piece case bolt adapter set with nut sizes 1/4 to 7/16 NF and NC threads is included in the propeller balancing kit. The stud portion is a 1/4 x 28 thread. To use the bolts/nuts during a typical propeller balance, select the adapter from the set to match the case bolts of a typical opposed engine. Attach the adapter nut end to the exposed case bolt threads then slide the right angle mount over the stud end and secure with the supplied nut. You will require two sets of the adapters for dual-engine balancing.

2.5.1.8 Tackle Box

A multi-compartment, high impact plastic, tackle box is included with the propeller balancing kit. The box has ample storage space for vibration sensors, vibration sensor mounts, and the case bolt adapter set. It may also serve as storage for AN washers used as balance weights.

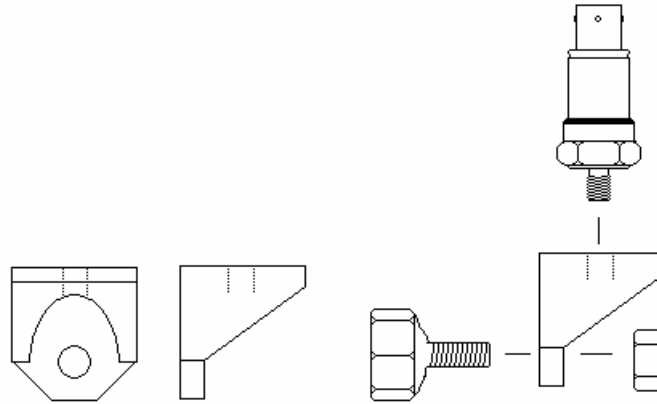

2.5.1.9 – Right-Angle Sensor Mount

The right-angle sensor mount shown in the left portion of the illustration above is made of anodized aluminum and designed to be mounted directly on the engine case bolt or to the case bolt adapter, shown in the right portion of the illustration above. The mount has a 1/4 x 28-threaded hole for the vibration sensor and a 1/4 unthreaded hole for the case bolt adapter stud.

2.5.1.10 - Gram Scale

A 150-gram capacity scale is included with the propeller balancing kit for weighing the washers or trim weights used in balancing. Read the operating instructions enclosed with the scale carefully prior to its use.

2.5.1.11 - Video Tape, *Using the Model 2020 ProBalancer Analyzer*

An instructional videotape is included with the balancing kit. The video provides basic instructions on equipment setup and ProBalancer operation. Refer to this manual for detailed instructions or call ACES Systems Customer Support at the number listed at the front of this manual if you have questions not addressed in the video.

2.5.1.12 - Reflective Tape

The reflective tape supplied with the propeller balancing kit is used as a tach trigger for the Phototach to generate a once-per-rev pulse used in speed readings and balancing calculations. The reflective tape (3M 7610) supplied with the propeller balancing kit was selected because of its excellent reflective quality and performance under varied operating conditions. Using a lower quality tape will cause inaccurate tachometer readings or unreliable phase information. The tape is manufactured by the 3M Company and is the only tape we recommend for use with the system. Contact ACES Systems for replacement tape. (See Chapter 15, “Equipment and Accessory Setup and Troubleshooting” for additional information for high RPM)