



Application Note

Turbomeca Arriel 2S1, 2S2 On Wing

Transient Vibration Survey

Part Number: 11-200-0212

AppNote Number: E-TM-ARRIEL2S12S2-4040-TVS (Rev. 0.00, Jan 2010)

This Application Note is provided for information only and does not supersede the requirements or guidelines set forth in the applicable engine or airframe maintenance manual. Technology for Energy Corporation assumes no obligation or liability, either expressed or implied, to the Purchaser arising out of the use of this procedure.

Copyright © 2010, TEC Aviation Division. All rights reserved. This document is to be printed and reproduced for personal use only.



Application Note

Application Note Number	E-TM-ARRIEL2S12S2-4040-TVS
Revision	0.00
Function	Transient Vibration Survey
Airframe	Sikorsky S76C+ and S76C++
Engine	Turbomeca Arriel 2S1, 2S2
E-Setup Number	e-tm-arriel-4040-tvs.asf Revision 0.00 or greater
ACES Systems Analyzer	Model 4040
Boot/App Version	3.05/3.05i
Procedure	On Wing

Introduction

This Application Note covers the required equipment, equipment installation, analyzer setup and data acquisition process for using the ACES Systems Model 4040 with the Transient Vibration Survey Performance Option to perform a transient vibration survey on the Turbomeca Arriel 2S1, 2S2. General instructions for the use of the Model 4040 can be found in the Model 4040 User Manual #4040-OM-01 (P/N 75-900-4040). All procedures for the transient vibration survey must be conducted in accordance with the applicable Maintenance Manual.

A. Required Equipment

The following equipment is required to perform a Transient Vibration Survey:

Item	Quantity	Description	Part Number
1.	1	Analyzer, Model 4040CE	10-100-4040CE
2.	1	Cable, Breakout, Arriel 2 Series	10-320-0326
3.	1	Sensor, Vibe, Accel, 6233C-10 and Model 538 Kit	Z69-100-0024
4.	1	Option, 4040 Transient Vibration Survey	11-900-0008

Optional Equipment

As specified by the appropriate Maintenance Manual.



Miscellaneous Equipment

Item	Quantity	Description	Part Number
5.	1	Cable, 4040 USB Comm	10-320-0483

Tape or tie wraps to secure equipment to airframe.

B. Equipment Installation

1. Park the aircraft on a flat level surface with the nose into the wind. Place the analyzer ([Item 1](#)) in the cabin.
2. Using three M4 x 0.70 x 12 mm screws (Component of [Item 3](#)), install a 6233C-10 Vibration Sensor (Component of [Item 3](#)) on the axial compressor casing sensor mount that is located behind the igniter box on the right-hand side of the engine. ([Figure 1](#))

NOTE

Secure and route cables as not to interfere with hot or rotating components and aircraft controls.

3. Connect a High Temperature Sensor Cable (Component of [Item 3](#)) to the forward vibration sensor. Safely route the cable under the engine avoiding electrical wiring and hot components as necessary. The cable should exit the engine cowling on the left-hand side of the aircraft and terminate in the Main Gear Box (MGB) area. ([Figure 1](#))
4. N1 and N2 Speed Breakout Cable ([Item 2](#)) installation. ([Figure 2](#))
 - 4.1 Disconnect the engine wiring harness at the P100 connector.
 - 4.2 Connect end of the Speed Breakout Cable marked P100/P101 ([Figure 3](#) Detail 1) to the P100 connector where you disconnected the Cable in [Step 4.1](#) above.
 - 4.3 Connect the P100 cable removed from the engine deck in [Step 4.1](#) above to the end of the Speed Breakout Cable marked J100/J101 ([Figure 3](#) Detail 2).
 - 4.4 Safely route the Speed Breakout Cable to the cabin area. Secure as necessary to prevent damage to the aircraft of cable.
 - 4.5 Connect the Speed Breakout Cable “NGG” lead, [Figure 3](#) Detail 3, to the “TACH 1” connector of the analyzer. ([Figure 4](#))
 - 4.6 Connect the Speed Breakout Cable “NTL” lead, [Figure 3](#) Detail 3, to the “TACH 4” connector of the analyzer. ([Figure 4](#))
5. Place a Model 538 Charge Converter (Component of [Item 3](#)) on the MGB deck. Connect the High Temperature Sensor Cable from the forward 6233C-10 Vibration Sensor as installed in [Step 3](#) above to the 2-socket connector on the Model 538. Connect the 4-socket end of a Sensor Cable (Component of [Item 3](#)) to the 4-pin connector on the Model 538. Safely secure and route the Sensor Cable forward toward the toward the left hand aft cabin door avoiding electrical wiring and hot components as necessary. The cable should exit the MGB area on the left-hand side of the aircraft, reenter the cabin through the left hand aft cabin door and terminate in the cabin area. Connect the 6-pin connector of the Sensor Cable to “CHANNEL A” on the analyzer.
6. Reinstall any previously removed cowlings, secure all cables and test equipment to prepare for ground runs.

Equipment Installation Diagram – locations typical

Figure 1

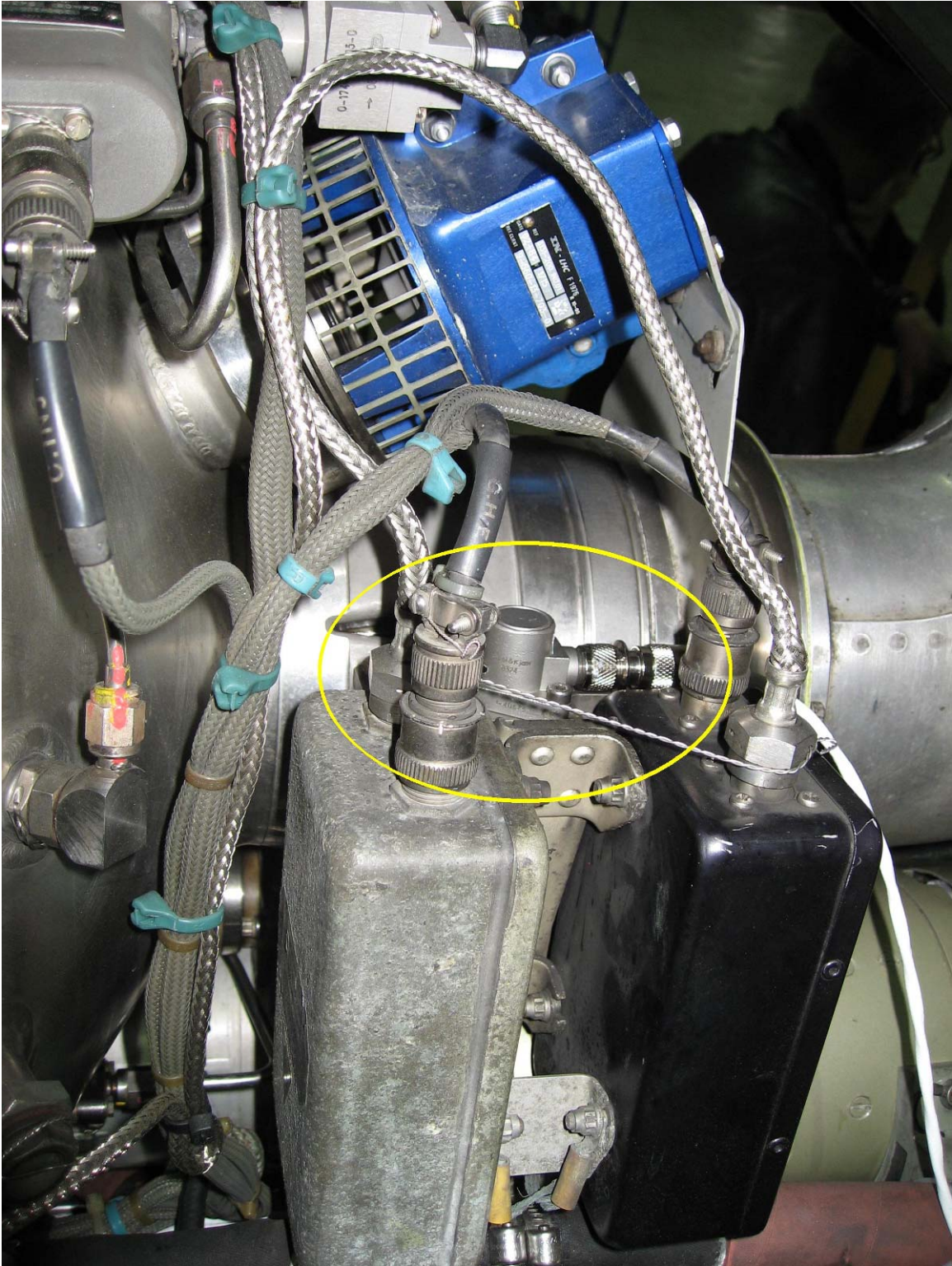

Figure 2



Figure 3

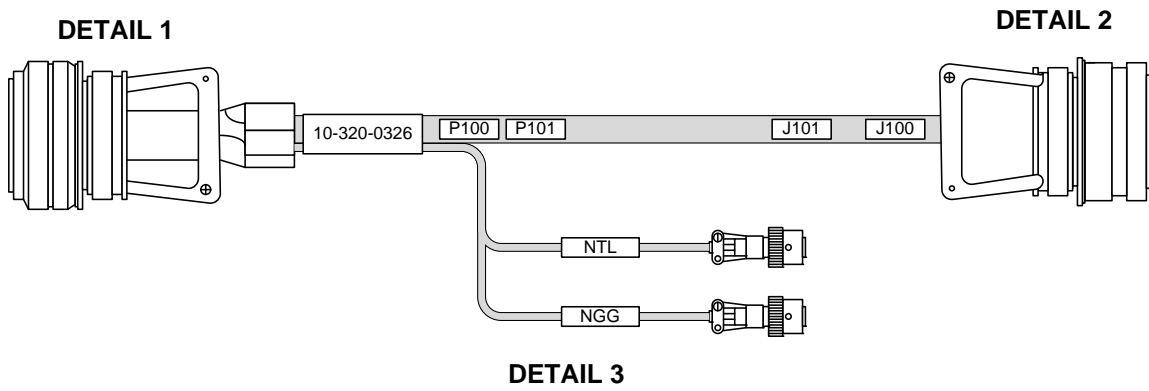
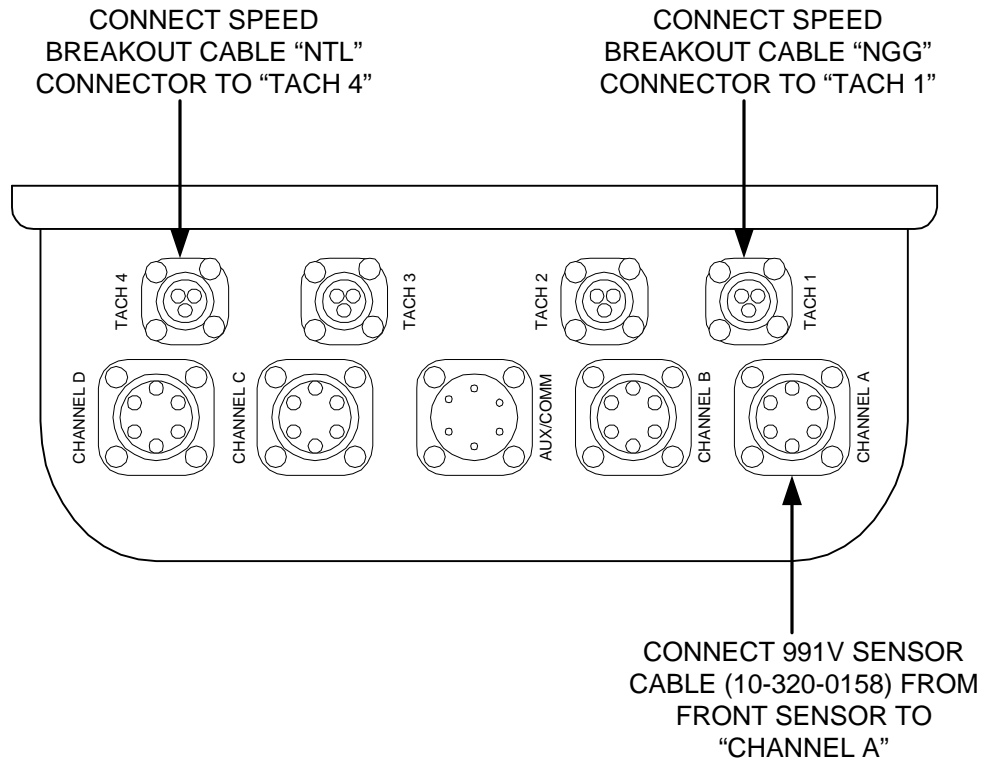
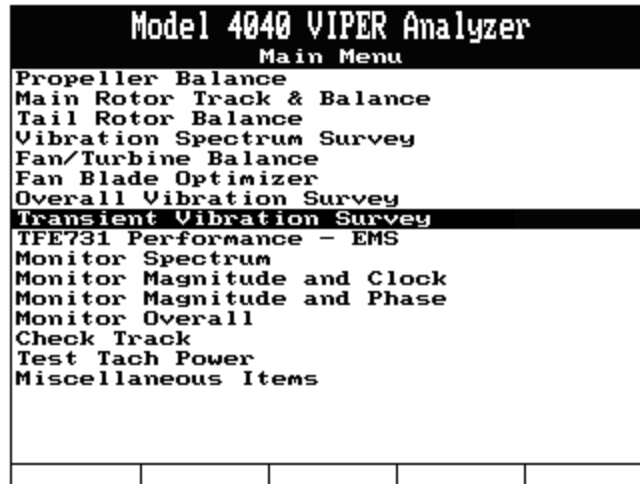

Figure 4



C. Analyzer Set Up

1. Turn the analyzer ON by pressing the **[ON/OFF]** key.
2. Insure the analyzer battery is charged prior to starting the job. See the Model 4040 User Manual #4040-OM-01 (P/N 75-900-4040) Chapter 2 for detailed instructions on battery charging.
3. From the Main Menu shown below, select "Transient Vibration Survey" and press the **[ENTER]** key.



4. From the Transient Vibration Survey Jobs Menu shown below, select “Start Job” and press the **[ENTER]** key.

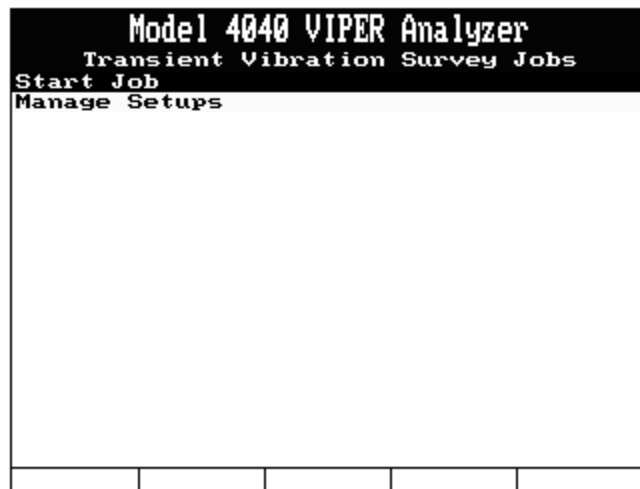

5. If the Turbomeca Arriel 2S1, 2S2 setups are listed in the Setup List, select the appropriate engine model and configuration using the **[↓]** key, press **[ENTER]** and go to [Section D below](#). If the Turbomeca Arriel 2S1, 2S2 setups are not in the Setup List or if the “Transient Survey Setup” screen appears, press **[BACKUP]** until the Main Menu is displayed and continue with [Step 6 below](#).

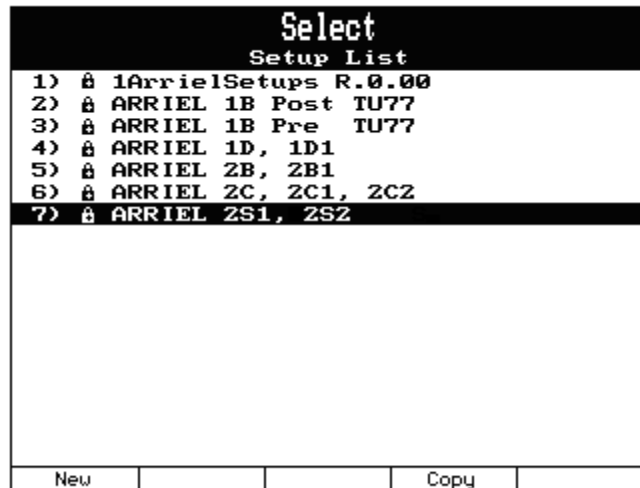
**NOTE**

Before beginning a job, ACES Systems recommends that you confirm this AppNote and your eSetups are current by visiting www.acesystems.com.

- You will have to download the setup library from the ACES Systems web site. Obtain access to a computer with internet access. Click the following link or enter the address into the address line of your internet browser. <http://www.acesystems.com/downloads/esetups/e-tm-arriel-4040-tvs.asf>. When prompted as shown in the screen below, save the file to your computer in a location where it can be easily found. This file is NOT a Windows Media Audio/Video playlist, it is a “Setup Library” that can be read in AvTrend or the analyzer. Do not try to open this file with a program other than AvTrend. This setup library will contain all of the setups for the Arriel Series of engines.

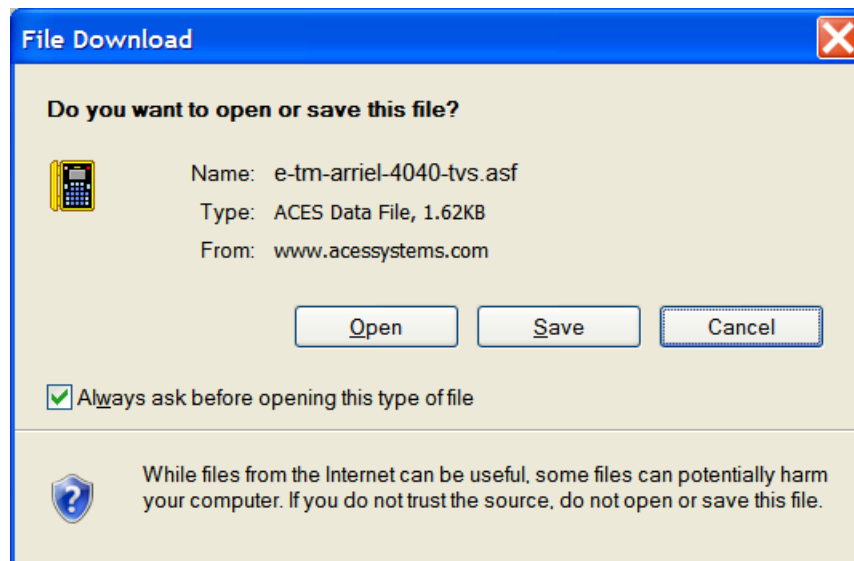

- After the file has downloaded, you will have to connect the 4040 Viper to the computer with the Comm Cable (Item 5). Insure the analyzer is turned on. Open AvTrend on the computer. You can check for updates to the AvTrend program at: <http://www.acesystems.com/applications.htm>.

CAUTION

**LOADING NEW SETUPS WILL OVERWRITE ANY DATA CURRENTLY STORED IN THE ANALYZER.
SAVE ALL DATA BEFORE LOADING ANY NEW SETUPS.**

8. Instructions for USB Transfer using Comm Cable (Item 5):
 - 8.1 Make sure the analyzer is displaying the Main Menu
 - 8.2 In AvTrend, insure that there is a “USB” icon in the upper right-hand corner of the AvTrend display as shown below. If the USB icon is not present, insure the analyzer is turned on and insure the proper drivers are loaded. Contact ACES Systems for additional help.



- 8.3 In AvTrend, Select “File|Transfer|Send Setups”
- 8.4 In the “Send Setup” window, find the file saved in [Step 6 above](#). Select the Setup Library and press “Send”.
- 8.5 AvTrend will display the message shown below. If you have forgotten to save the data in the analyzer answer “Yes” to save it now. If you have already saved the data or do not wish to save the data, answer “No” to proceed.

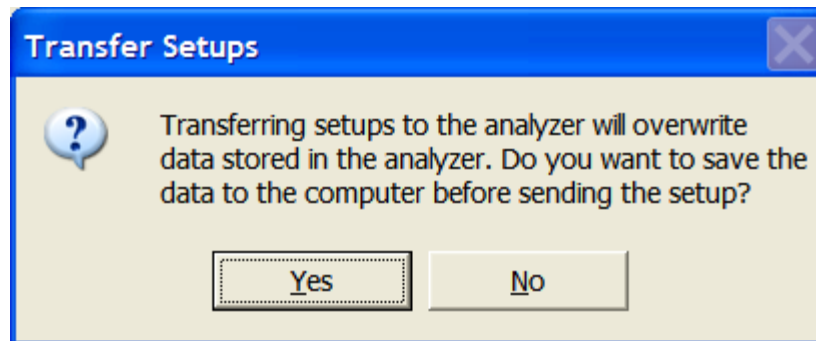

- 8.6 The rest of the transfer should be automatic.
9. Repeat [Steps 3](#) and [5 above](#) and insure that the correct setup is available for use. Select the appropriate setup and continue with [Section D below](#).

D. Data Acquisition

1. Start the engine in accordance with the flight and/or maintenance manual instructions. While the engine is warming up, proceed to [Step 2 below](#).
2. The “Job Identification” screen should be displayed, as shown below. Use the analyzer keypad to enter a customer name in the “Name:” field. The analyzer will maintain a list of customer names as new names are entered. If names have been previously entered into this analyzer, you may press the [F1] “Names” key and select a customer’s name from the provided list. Press the [↓] key to move to the next field and use the analyzer keypad to enter the optional aircraft registration and aircraft total time as required. When all fields are complete, press the [ENTER] key to accept and continue.

Model 4040 VIPER Analyzer				
Job Identification				
Name :	CUSTOMER NAME			
A/C Registration:	F-XYZ			
A/C Total Time:	123.4			
Press ENTER to continue				
Names				

3. The next screen to be displayed will be the “Engine Information” screen as illustrated below. This screen gives the opportunity to enter information about the engine under test. Enter as much or as little information as necessary. This is for record keeping purposes only and will not influence the job in any way. Use the [F1] “Serial Nos” key to access a database of recently entered Serial Numbers as used in previous jobs. Press the [ENTER] key when finished to progress to the next screen.

Model 4040 VIPER Analyzer				
Engine Information				
Position:	1			
Propeller:				
S/N				
Type				
TSO	0			
TSN	0			
Engine:				
S/N	123			
Type	ARRIEL2S			
TSO	123			
TSN	123			
Serial Nos				

NOTE

You must start the engine within 3 minutes of stopping it or wait 20 minutes to start it again for this test.

CAUTION

DO NOT DO THE VIBRATION SURVEY BETWEEN 3 AND 20 MINUTES AFTER THE ENGINE STOPS. READINGS TAKEN DURING THIS PERIOD ARE INVALID DUE TO THERMAL UNBALANCE IN THE ENGINE.

4. While the engine warms up to an oil temperature of at least 50°C, (122° F) read [Steps 5](#) through [8 below](#) to prepare for data collection.

5. The “Start Engine” screen will read “Perform FOD check, start the engine, and establish normal operating conditions”. Keep the engine running, press the **[ENTER]** key and wait for the analyzer to display the “Overall Vibration” screen. Proceed directly to [Step 6 below](#). Should you need to exit the “Start Engine” screen, press the **[F2]** “Swap Job” key to go directly to the Main Menu.

NOTE

This is not a recommendation from Turbomeca to perform a Foreign Object Damage inspection. This is only an informational line prompting you to search the local area for Foreign Object Debris before starting the engine.

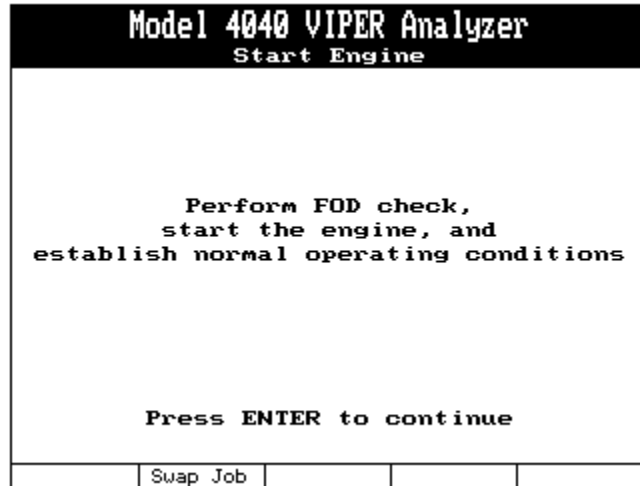

6. The analyzer will display the “Overall Vibration” screen. The “Samples”, “Events” and “Press F5 to record” lines will flash until actual data is being recorded. The values in the “Current” column should indicate actual engine speed. When the engine reaches normal operating oil temperature and while the analyzer shows the “Overall Vibration” screen, shut down the engine. Monitor the engine readings until the engine is stopped. If any anomalies are observed during the shutdown, determine the cause before proceeding to [Step 7](#) to record data.

Model 4040 VIPER Analyzer			
Overall Vibration			
Samples: +	Events: +		
	Current	Maximum	Units
			%RPM
CFRONT	1.11	0.00	mm/sec
NGG	35706.09	0.00	70.0
NPT	22579.87	0.00	58.8
Press F5 to record.			
CFRONT		CREAR	Record

7. Press the [F5] “Record” key. The Samples count will begin to increase, the Events value will read zero and the “Press F5 to record.” line will disappear. **IMMEDIATELY**, begin the engine start sequence. The actual speed and vibration values will be displayed as the engine is accelerating. Accelerate the engine to flight idle and stabilize at this speed. Use the [F1] “CFRONT” key to view the readings for the Front Sensor. Use the [F5] “Event” key to add an event marker to the collected data.

Model 4040 VIPER Analyzer				
Overall Vibration				
Samples: 209		Events: 0		
	Current	Maximum	Units	%RPM
CFRONT	1.11	2.19	mm/sec	
NGG	35706.09	35659.49		70.0
NPT	22579.87	24469.37		58.8
CFRONT				Event

8. When the engine reaches flight idle, press [ENTER] to terminate data acquisition. The screen will display the message “STORE THE DATA?” Press the [F1] “Yes” key to store the data then proceed to [Step 9 below](#). If you wish to conduct another survey without saving the data, press the [F5] “No” key. This will return you to the Start Engine screen, [Step 5 above](#), where you may begin another survey.

Model 4040 VIPER Analyzer				
Store the data?				
Yes				No

9. The screen will display the information message “Shut down engine(s) per manual instructions”. At this time you may shut down the engine in accordance with flight or maintenance manual procedures.

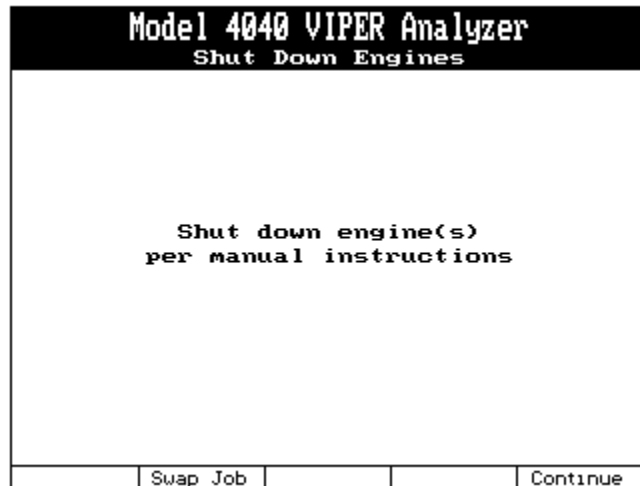

E. Quit Job

1. Press the **[F5]** "Continue" key to acknowledge the message and continue. The screen will again display the "Transient Vibration Survey Jobs" menu. From this screen, you may review the data you just collected by moving the highlight bar to "Manage Jobs" and pressing **[ENTER]**. From the "Transient Vibration Survey Jobs" screen, choose "Review" and press **[ENTER]**. From the next screen, choose the job you wish to review from the Job List and press **[ENTER]**. The jobs are sorted in order of time and date taken.
2. You can also download the data to AvTrend for additional review or printing. Please see the AvTrend Silver Manual for specific instructions.
3. Remove all test equipment and return the aircraft to airworthy condition.