



Application Note

Rolls Royce M250 Series

Engine Vibration Survey

Part Number: 11-200-0273

AppNote Number: E-ROM250-4040-VI (Rev. 3.02, Jan 2011)

This Application Note is provided for information only and does not supersede the requirements or guidelines set forth in the applicable engine or airframe maintenance manual. Technology for Energy Corporation assumes no obligation or liability, either expressed or implied, to the Purchaser arising out of the use of this procedure.

Copyright © 2009 – 2011, TEC Aviation Division. All rights reserved. This document is to be printed and reproduced for personal use only.



Application Note

Application Note Number	E-ROM250-4040-VI
Revision	3.02 (From CSL Rev. 8, Aug 2009)
Function	Engine Vibration Survey
Airframe	Various
Engine	Rolls Royce M250 Series
E-Setup Number	e-rom250-4040-vi.asf
ACES Systems Analyzer	Model 4040
Boot/App Version	3.xx/3.xx or later
Procedure	N/A

Introduction

This Application Note covers the required equipment, equipment installation, analyzer setup, and data acquisition process for using the ACES Systems Model 4040 Viper Analyzer to perform an engine vibration survey on the Rolls Royce M250 Series. General instructions for the use of the Model 4040 can be found in the Model 4040 User Manual #4040-OM-01 (P/N 75-900-4040). All procedures and adjustments should be made in accordance with the Engine Maintenance Manual.

A. Required Equipment – All

The following equipment is required to perform an Engine Vibration Survey on all M250 Series engines*:

Item	Quantity	Description	Part Number
1.	1	Analyzer, Model 4040	10-100-4040
2.	3	Sensor, 6222S-20, W/510 Chg Conv & Cbl	Z10-100-1510

Required Equipment – Series I and II Turboshaft applications (C18 and C20 Models)

The following equipment is required to perform an Engine Vibration Survey on all M250 Series I and II engines in Turboshaft applications*:

Item	Quantity	Description	Part Number
3.	1	Mount, Sens, AGB, A250 (RR P/N 23032993)	22-430-0123
4.	1	Mount, Sens, T-type, A250 (RR P/N 23032992)	22-430-0124
5.	1	Mount, Sens, T-type, A250 (RR P/N 23032992)	22-430-0124

Required Equipment – Series III and IV Turboshaft applications (C28, C30, C40 and C47 Models)

The following equipment is required to perform an Engine Vibration Survey on all M250 Series III and IV engines in Turboshaft applications*:

Item	Quantity	Description	Part Number
3.	1	Mount, Sens, AGB, A250 (RR P/N 23032993)	22-430-0123
4.	1	Mount, Sens, T-type, A250 (RR P/N 23032992)	22-430-0124
5.	1	Mount, Sens, Comp, A250 (RR P/N 23034204)	22-430-0125

Required Equipment – Series II Turboprop applications (B17 Models)

The following equipment is required to perform an Engine Vibration Survey on all M250 Series II engines in Turboprop applications*:

Item	Quantity	Description	Part Number
3.	1	Mount, Sens, AGB, A250 (RR P/N 23032993)	22-430-0123
4.	1	Mount, Sens, Turbine, A250-B17 (RR P/N 23038047)	22-430-0122
5.	1	Mount, Sens, T-type, A250 (RR P/N 23032992)	22-430-0124
6.	1	Mount, Sens, T-type, A250 (RR P/N 23032992)	22-430-0124
7.	1	Sensor, 6222S-20, W/510 Chg Conv & Cbl	Z10-100-1510

*This listing shows the latest design parts. It is acceptable to perform this task using previous designs with the appropriate accessories. For compatibility issues, contact ACES Systems.

Optional Equipment

The following equipment may be used as an alternate on the Compressor, Accessory Gearbox, or Propeller Reduction Gearbox when accomplishing the job:

Item	Quantity	Description	Part Number
8.	3	Sensor, Vibration, Velocity, 991V	69-100-0064
9.	1	Mount, 991V Sens Comp	Locally Fabricated
10.	1	Mount, 991V AGB	Locally Fabricated
11.	As Req	Cable, Sensor, 991V – 2020/4040 25 ft	10-320-0158

Miscellaneous Equipment

Tape or tie wraps to secure cables to airframe.

B. Equipment Installation

1. Park the aircraft on a flat level surface with the nose into the wind. Place the Analyzer ([Item 1](#)) in the flight compartment.

NOTE

Secure and route cables as not to interfere with hot or rotating components and aircraft controls.

2. Compressor:
 - 2.1 (Turboshaft applications) Install the Compressor Mount ([Item 5](#) applicable to engine model under test) on the front side of the compressor-to-inlet housing splitline at the 12 o'clock position. Install a High Temperature Sensor (component of [Item 2](#)) onto the Sensor Mount. Connect High Temperature Sensor Cable (component of [Item 2](#)) to the Sensor and to the 510 Charge Converter (component of [Item 2](#)). It is acceptable to use a 991V Vibration Sensor (Optional [Item 8](#)) in this location provide a suitable sensor mount is fabricated. Connect the 991V sensor cable (component of [Item 2](#) or Optional [Item 11](#)) to the Charge Converter or 991V Sensor, safely route the cable into the cabin area and connect the cable end to "CHANNEL A" on the analyzer. ([Figure 1](#))
 - 2.2 (Turboprop applications) Install the Compressor mount ([Item 5](#) applicable to engine model under test) on the front side of the compressor-to-inlet housing splitline at the 6 o'clock position. Install a High Temperature Sensor (component of [Item 2](#)) onto the Sensor Mount. Connect High Temperature Sensor Cable (component of [Item 2](#)) to the Sensor and to the 510 Charge Converter (component of [Item 2](#)). It is acceptable to use a 991V Vibration Sensor (Optional [Item 8](#)) in this location provide a suitable sensor mount is fabricated. Connect the 991V sensor cable (component of [Item 2](#) or Optional [Item 11](#)) to the Charge Converter or 991V Sensor, safely route the cable into the cabin area and connect the cable end to "CHANNEL A" on the analyzer. ([Figure 2](#))
3. Accessory Gearbox:
 - 3.1 (Turboshaft applications) Install the Accessory Gearbox vibration sensor mount ([Item 3](#) applicable to engine model under test) on the power and accessory gearbox top engine mounting pad. Install a High Temperature Sensor (component of [Item 2](#)) onto the Sensor Mount. Connect High Temperature Sensor Cable (component of [Item 2](#)) to the Sensor and to the 510 Charge Converter (component of [Item 2](#)). It is acceptable to use a 991V Vibration Sensor (Optional [Item 8](#)) in this location provide a suitable sensor mount is fabricated. Connect the 991V sensor cable (component of [Item 2](#) or Optional [Item 11](#)) to the Charge Converter or 991V Sensor, safely route the cable into the cabin area and connect the cable end to "CHANNEL B" on the analyzer. ([Figure 1](#))
 - 3.2 (Turboprop applications) Install the Accessory Gearbox vibration sensor mount ([Item 3](#) applicable to engine model under test) on the power and accessory gearbox mounting pad at the 6 o'clock position. Install a High Temperature Sensor (component of [Item 2](#)) onto the Sensor Mount. Connect High Temperature Sensor Cable (component of [Item 2](#)) to the Sensor and to the 510 Charge Converter (component of [Item 2](#)). It is acceptable to use a 991V Vibration Sensor (Optional [Item 8](#)) in this location provide a suitable sensor mount is fabricated. Connect the 991V sensor cable (component of [Item 2](#) or Optional [Item 11](#)) to the Charge Converter or 991V Sensor, safely route the cable into the cabin area and connect the cable end to "CHANNEL B" on the analyzer. ([Figure 2](#))
4. Turbine:

- 4.1 (Turboshaft applications) Install Sensor Mount ([Item 4](#) applicable to engine model under test) on the forward side of the gas producer-to-power turbine support split-line at the 12 o'clock position. Install a High Temperature Sensor (component of [Item 2](#)) onto the Sensor Mount. Connect High Temperature Sensor Cable (component of [Item 2](#)) to the Sensor and to the 510 Charge Converter (component of [Item 2](#)). Connect the end marked "991V" of the Vibration Sensor Cable (component of [Item 2](#) or Optional [Item 11](#)) to the Model 510 charge amplifier. Route the cable safely and securely into the cabin area. Connect the end to "CHANNEL C" on the analyzer. ([Figure 1](#))
 - 4.2 (Turboprop applications) Install Sensor Mount ([Item 4](#) applicable to engine model under test) on the forward side of the gas producer-to-power turbine support split-line at the 6 o'clock position. Install a High Temperature Sensor (component of [Item 2](#)) onto the Sensor Mount. Connect High Temperature Sensor Cable (component of [Item 2](#)) to the Sensor and to the 510 Charge Converter (component of [Item 2](#)). Connect the end marked "991V" of the Vibration Sensor Cable (component of [Item 2](#) or Optional [Item 11](#)) to the Model 510 charge amplifier. Route the cable safely and securely into the cabin area. Connect the end to "CHANNEL C" on the analyzer. ([Figure 2](#))
5. Turboprop Engines Only: Install a vibration pickup mount ([Item 6](#)) on the front side of the front prop reduction gearbox splitline at the 12:30 position looking from rear to front. Install a High Temperature Sensor (component of [Item 7](#)) onto the Sensor Mount. Connect High Temperature Sensor Cable (component of [Item 7](#)) to the Sensor and to the 510 Charge Converter (component of [Item 7](#)). It is acceptable to use a 991V Vibration Sensor (Optional [Item 8](#)) in this location provide a suitable sensor mount is fabricated. Connect the 991V sensor cable (component of [Item 2](#) or Optional [Item 11](#)) to the Charge Converter or 991V Sensor, safely route the cable into the cabin area and connect the cable to the Model 510 charge amplifier. Route the cable safely and securely into the cabin area. Connect the end to "CHANNEL D" on the analyzer. ([Figure 2](#))
6. Reinstall any previously removed cowlings. Return aircraft to flying configuration.

Equipment Installation Diagram

Figure 1

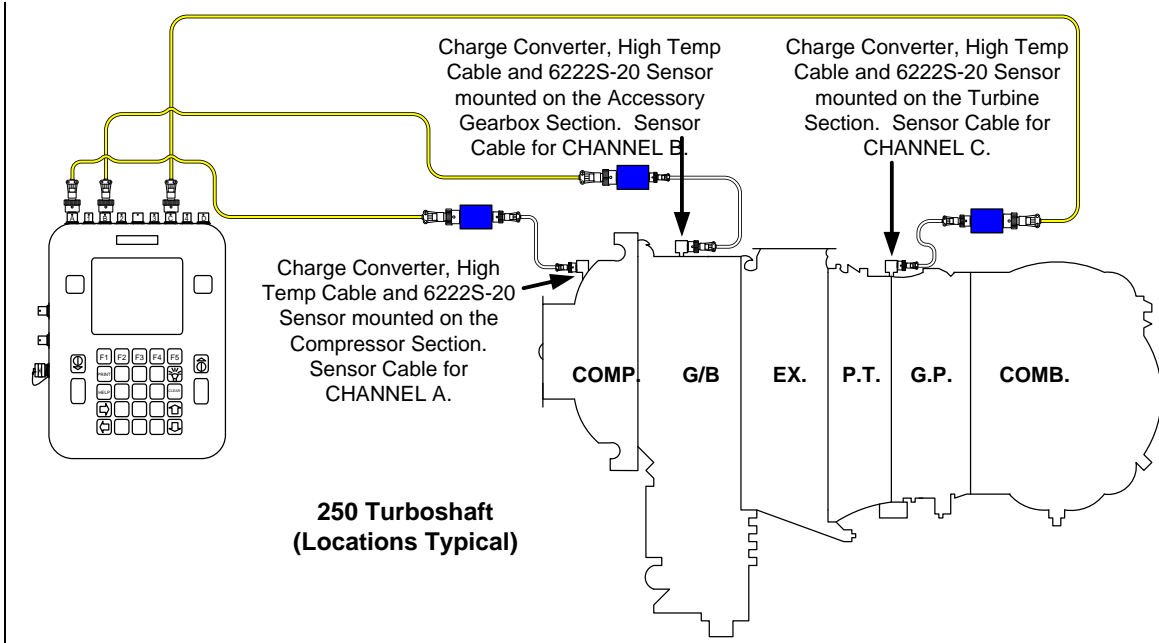
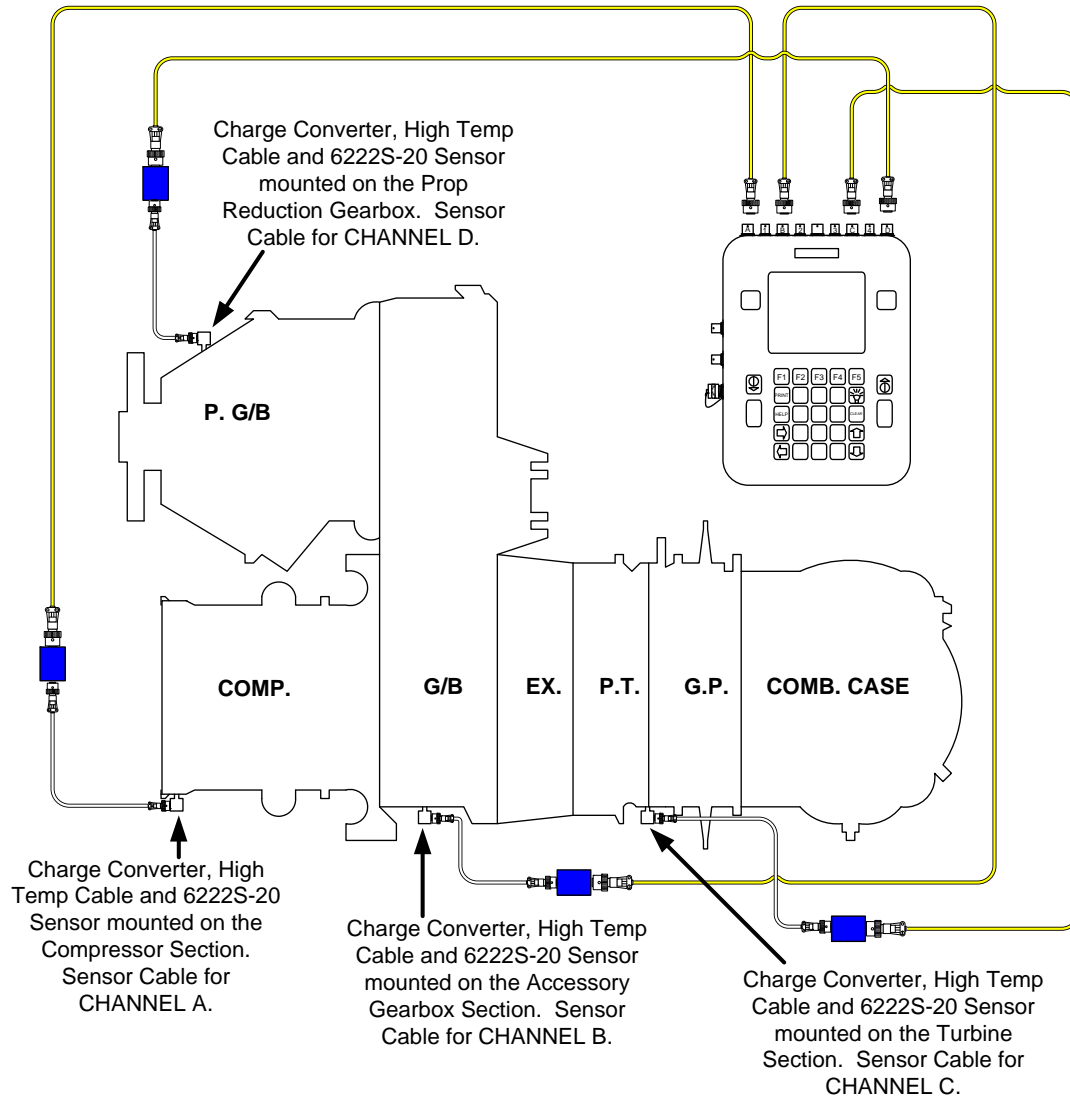
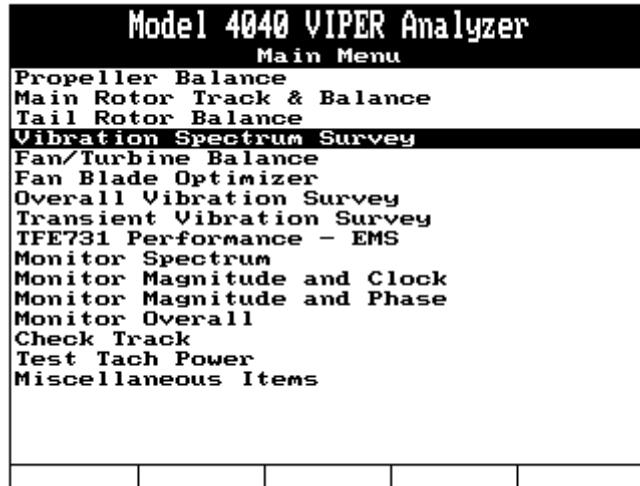

Figure 2
M250 Turboprop
(Locations Typical)



C. Analyzer Set Up

1. Insure the analyzer battery is charged prior to starting the job. See the Model 4040 User Manual #4040-OM-01 (P/N 75-900-4040) Chapter 2 for detailed instructions on battery charging.
2. Turn the analyzer ON by pressing the [ON/OFF] key.
3. From the Main Menu shown below, select “Vibration Spectrum Survey” and press the [ENTER] key.



- From the Vibration Spectrum Survey Menu shown below, select "Manage Setups" and press the [ENTER] key.

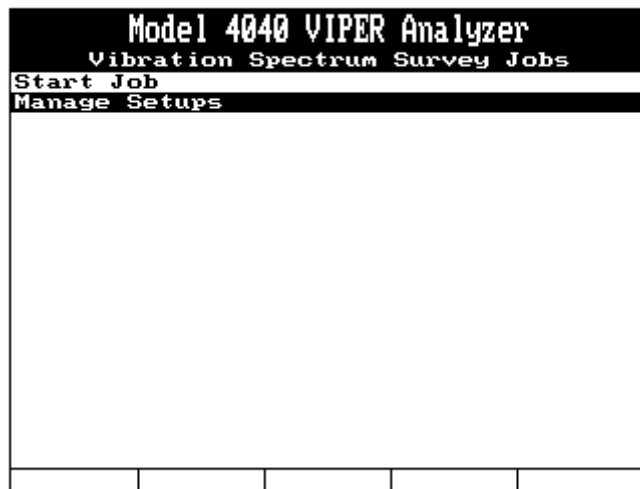

- From the Vibration Spectrum Survey Setups menu shown below, select "Edit" and press the [ENTER] key.

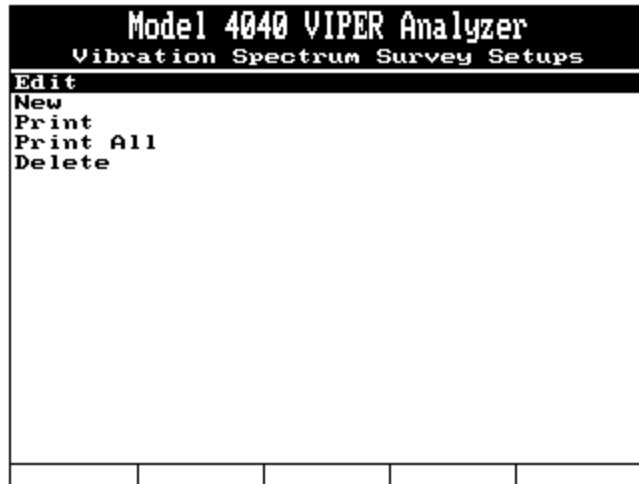

6. If the setup required for the Rolls Royce M250 Series is already loaded in the analyzer it will display the Setup List similar to the one shown below. Press **[BACKUP]** to return to the “Vibration Spectrum Survey” menu and continue with [Section D below](#).

If the setup for the Rolls Royce M250 Series is not in the Setup List or if the analyzer displays a blank “Spectra Setup” screen, it will be easiest to create a “Sensor Setup” before proceeding, therefore, press **[MAIN MENU]** to return to the Main Menu and continue with [Step 7 below](#).



Sensor Setup

7. From the Main Menu shown below, select “Miscellaneous Items” and press the **[ENTER]** key.

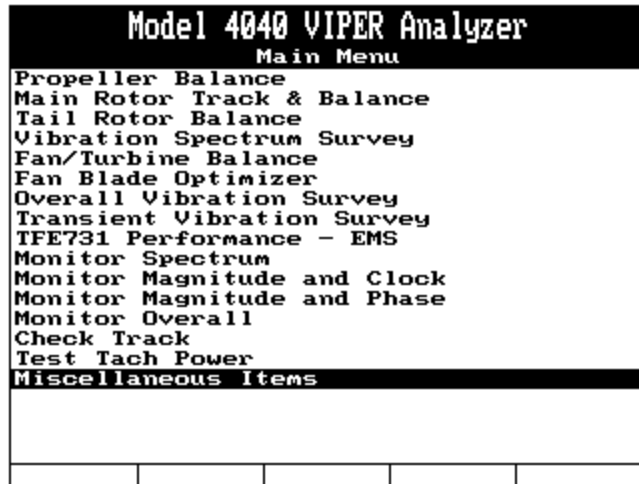

8. From the Miscellaneous Items menu select “Setup Sensors” and press [ENTER].

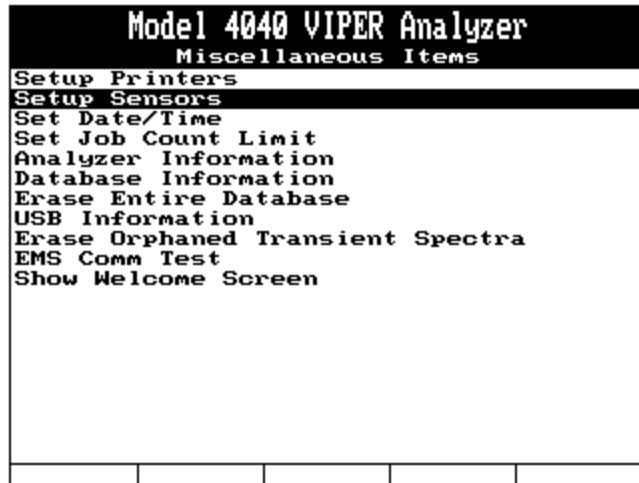

9. From the Manage Sensors menu select “Edit” and press [ENTER].

Model 4040 VIPER Analyzer				
Sensor Setup				
Name:	6222S-20 W/510			
Amplitude Units:	IPS			
Probe Sensitivity:	20.000			
Reverse Polarity:	No			
Input Type:	Single Ended			

12. The analyzer will display the “Manage Sensors” menu again. Press the [BACKUP] key twice to return to the Main Menu.

Model 4040 VIPER Analyzer				
Manage Sensors				
Edit				
New				
Print				
Print All				
Delete				

13. From the Main Menu shown below, select “Vibration Spectrum Survey” and press the [ENTER] key.

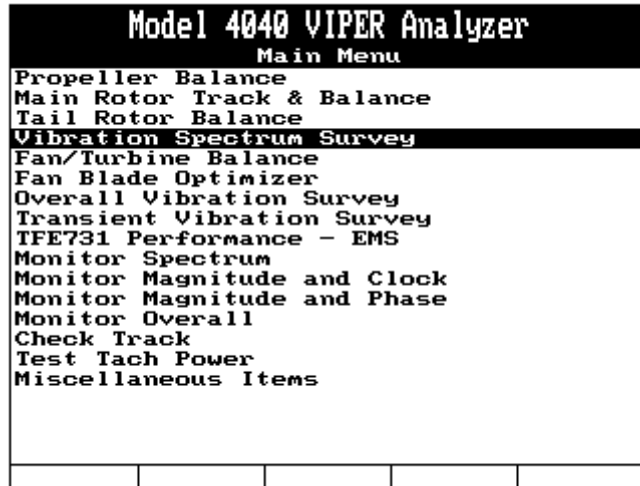

14. From the Vibration Spectrum Survey Menu shown below, select “Manage Setups” and press the [ENTER] key.

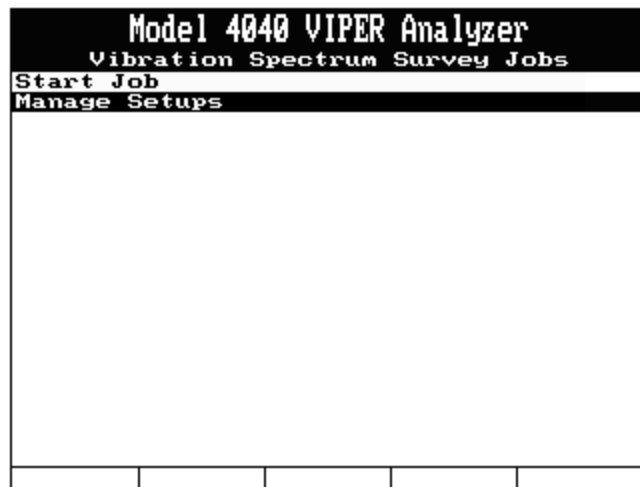

15. From the Vibration Spectrum Survey Setups menu select “New” and press [ENTER].

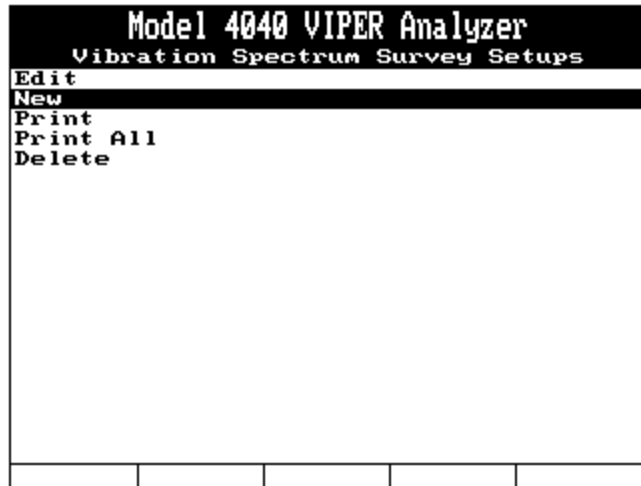

16. The “Spectra Setup” screen now appears. Enter the Spectra Setup as shown below. You can enter any name that is convenient for locating the setup in the future. This setup will record data used when monitoring the engine trend. When completed press [F1] “Edit Conds” to define the power settings where data will be acquired.

NOTE

Turboshaft applications need not configure Channel D for Propeller Reduction Gearbox measurements.

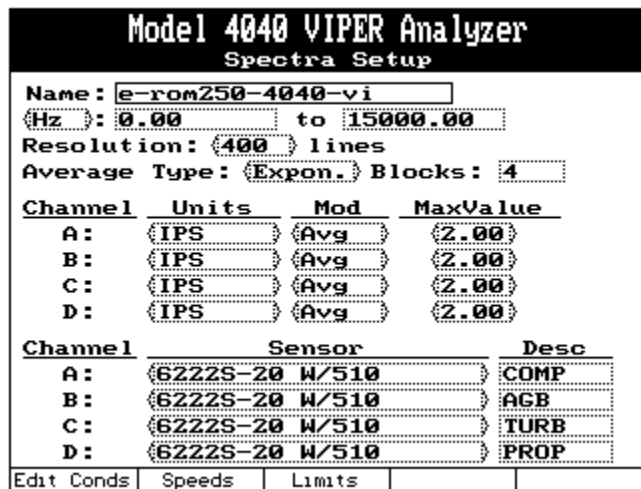

17. The “Condition” screen will be displayed next. Enter the values as shown in the illustration below. Press [ENTER] to continue.

The required flight conditions as defined in the Maintenance Manual should be reviewed. Due to limited space, not all engine/flight conditions can be completely described and abbreviations are sometimes used.

CAUTION

The engine speed settings in this procedure are only suggestions. Insure all N2 speed avoidance ranges applicable to the engine model are observed.

- “GND IDL” means to operate the aircraft with the engine at ground idle.
- “85% N2” means to operate the aircraft at 85% N2 engine speed with no defined N1 speed.
- “FPG 100%” means operate the aircraft at Flat Pitch on the Ground at 100% N2 engine speed.
- “87% 100%” means to operate the aircraft at 87% N1 and 100% N2 engine speed.
- “95% 100%” means to operate the aircraft at 95% N1 and 100% N2 engine speeds.
- “IN FLIGHT” means to fly the aircraft using maximum allowable power in level flight at a safe altitude with the engine at 100% N2.
- “FLT +3000” means to fly the aircraft at maximum allowable power in level flight 3000 feet above the altitude where readings for the condition above were obtained.

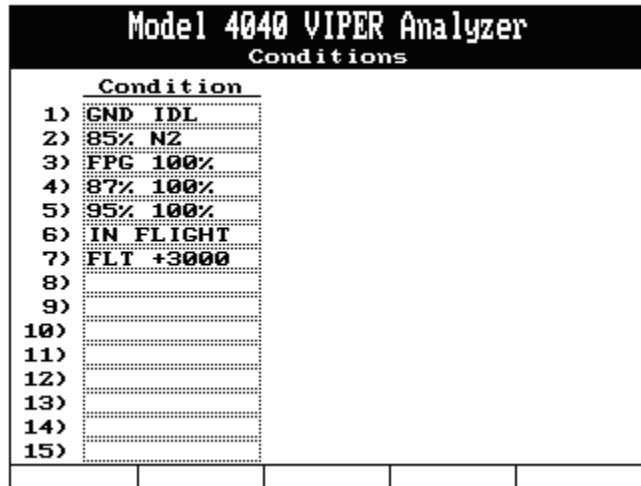

18. The screen will display the “Spectra Setup” screen as shown below. Press the [F3] “Limits” key to access the “Limits” function key menu as shown below.

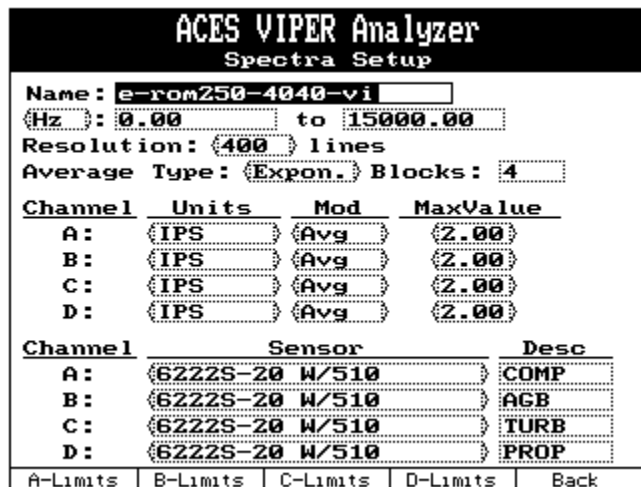

19. Press the [F1] “A-Limits” key to define the limits for Channel A. Complete the fields as shown below. When all entries are made on this screen, press the [F1] “CopyToAll” key to copy these settings to the remaining channels. Then, press [ENTER] to return to the “Spectra Setup” screen as shown in [Step 16 above](#).

ACES VIPER Analyzer				
Edit Limits for Channel A: COMP				
	F-low	F-high	Unit	Limit
1)	0.00	15000.00	xHz	1.00
2)	0.00	0.00	xCS1	0.00
3)	0.00	0.00	xCS1	0.00
4)	0.00	0.00	xCS1	0.00
5)	0.00	0.00	xCS1	0.00
6)	0.00	0.00	xCS1	0.00
7)	0.00	0.00	xCS1	0.00
8)	0.00	0.00	xCS1	0.00
9)	0.00	0.00	xCS1	0.00
10)	0.00	0.00	xCS1	0.00
11)	0.00	0.00	xCS1	0.00
12)	0.00	0.00	xCS1	0.00
13)	0.00	0.00	xCS1	0.00
14)	0.00	0.00	xCS1	0.00
CopyToAll		CopyToB	CopyToC	CopyToD

20. From the “Spectra Setup” page, press [ENTER] to store the complete setup.
21. From the “Manage Setups” menu shown below, press the [BACKUP] key to return to the “Vibration Spectrum Survey” menu.

D. Data Acquisition

1. From the “Vibration Spectrum Survey Jobs” menu, shown below, select “Start Job” and press [ENTER].

Model 4040 VIPER Analyzer				
Vibration Spectrum Survey Jobs				
Start Job				
Manage Setups				

2. From the “Setup List” screen, shown below, select “e-rom250-4040-vi” setup and press [ENTER].

Select				
Setup List				
1)	e-rom250-4040-vi			
2)	BRAND X HELICOPTER			
3)	BRAND Y HELICOPTER			
4)	BRAND Z HELICOPTER			
New			Copy	

3. The “Job Identification” screen will be displayed, as shown below. Use the analyzer keypad to enter a customer name in the “Name:” field. The analyzer will maintain a list of customer names as new names are entered. If names have been previously entered into this analyzer, you may press the [F1] “Names” key and select a customer’s name from the provided list. Press the [↓] key to move to the next field and use the analyzer keypad to enter the optional aircraft registration and aircraft total time as required. When all fields are complete, press the [ENTER] key to accept and continue.

Model 4040 VIPER Analyzer				
Job Identification				
Name: CUSTOMER NAME				
A/C Registration: N1234				
A/C Total Time: 123.4				
Press ENTER to continue				
Names				

4. The next screen to be displayed is the “Engine Information”, as shown below. The information entered on this screen is optional. Entering as much information as possible will help complete the final report.

Model 4040 VIPER Analyzer				
Engine Information				
Position:				
< 1 >				
Propeller:				
S/N				
Type				
TSO	0			
TSN	0			
Engine:				
S/N				
Type				
TSO	0			
TSN	0			
Serial Nos				

5. The analyzer will display the “Start Engine” screen. “Perform FOD check, start the engine, and establish normal operating condition.” When the engine is stabilized, press [ENTER] to continue. You can use the [F2] “Swap Job” key to return directly to the Main Menu without rebooting the analyzer.

Model 4040 VIPER Analyzer				
Start Engine				
Perform FOD check, start the engine, and establish normal operating conditions				
Press ENTER to continue				
Swap Job				

6. The analyzer will display the “Select Condition” screen as displayed below. Select the condition that you want to gather data for using the [↑] [↓] arrows and press [ENTER]. Pressing [F1] “End Run” will allow you to exit the current job and leave it incomplete in the analyzer. You can resume this job at a later date. Pressing [F5] “Quit Job” will mark the current job complete in the analyzer. You cannot resume this job at a later date.

Model 4040 VIPER Analyzer				
Select Condition				
<input type="checkbox"/>	GND	IDL		
<input type="checkbox"/>	85%	NZ		
<input type="checkbox"/>	FPG	100%		
<input type="checkbox"/>	87%	100%		
<input type="checkbox"/>	95%	100%		
<input type="checkbox"/>	IN	FLIGHT		
<input type="checkbox"/>	FLT	+3000		
End Run				Quit Job

7. The analyzer will present the data acquisition screen as shown below. This screen allows you to monitor both the current and averaged vibration readings. Operate the aircraft in the configuration for the selected condition and allow the analyzer to collect data. While monitoring the measurement, you may press the [F5] “Reset” key to restart the averaging process. Use this feature as a way to validate the quality of the measurement. If the averaged readings return to a value similar to the displayed value prior to being “Reset”, the measurement can be considered good. If the measurement is not similar, you may choose to “Reset” the average again. Press the [ENTER] key to stop acquisition. The solid line at 1.0 IPS Avg is the limit line. Values near or in excess of this line should be investigated.

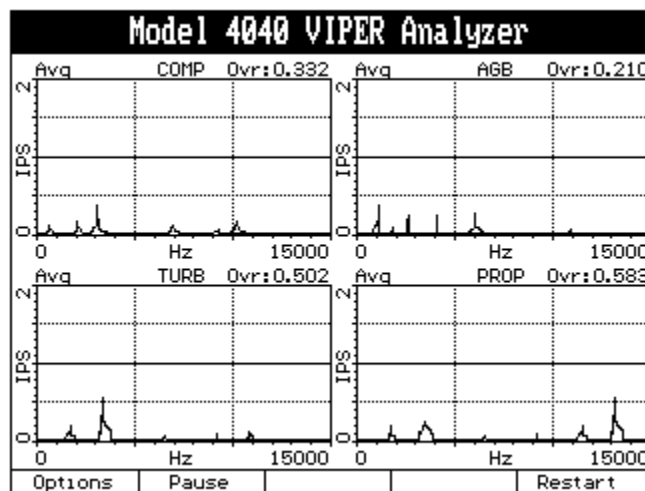

See the Model 4040 User Manual #4040-OM-01 (P/N 75-900-4040) Chapter 20 for detailed instructions on how to read the “Reading the X and Y Plotted Vibration Spectrum.”

8. The analyzer will display the screen shown below. If the data is good, press the [F1] “Yes” key to store the data. If you need to retake the data for some reason, press the [F2] “No” key.

Model 4040 VIPER Analyzer				
Store the data?				
Yes				No

- The analyzer will display the “Select Condition” screen showing any conditions that have already had data stored with an [x] preceding the condition name. Continue to take data until all conditions have been acquired.

Model 4040 VIPER Analyzer				
Select Condition				
[x]	GND	IDL		
[]	85%	N2		
[]	FPG	100%		
[]	87%	100%		
[]	95%	100%		
[]	IN	FLIGHT		
[]	FLT	+3000		
End Run				Quit Job

E. Quit Job

- After data is taken in the last condition and the data has been stored, the “Shut Down Engines” screen will appear with the message, “Shut down engine(s) per manual instructions.” When the engine shut down process is complete, press the [F3] “Continue” key. This will complete the job. Pressing the [F2] “Swap Job” key will leave the job incomplete and return you directly to the Main Menu without rebooting the analyzer. This will allow you to resume the job at a later date.



- 2. The job can be reviewed in the analyzer by using the “Manage Jobs” function under the “Vibration Spectrum Survey Jobs” menu as shown below. The data can also be downloaded to AvTrend for review and evaluation. See the appropriate AvTrend manual for detailed instructions.

