



# Application Note

---

## Pratt & Whitney PT6 A/B Series

### Transient Vibration Survey

Part Number: 11-200-0256

AppNote Number: E-PWPT6-4040-TVS (Rev. 1, Dec 2008)

This Application Note is provided for information only and does not supersede the requirements or guidelines set forth in the applicable engine or airframe maintenance manual. Technology for Energy Corporation assumes no obligation or liability, either expressed or implied, to the Purchaser arising out of the use of this procedure.

Copyright © 2008, TEC Aviation Division. All rights reserved. This document is to be printed and reproduced for personal use only.



# Application Note

Application Note Number	E-PWPT6-4040-TVS
Version	1
Function	1ENG & 1/3ENG (AGB) and 1ENF Surveys
Airframe	Test Cell
Engine	PT6A/B ALL Models
Other Application Notes Required	none
ACES Systems Analyzer	Viper 4040
Firmware Version	3.05 or greater
Procedure Cards	N/A

## Introduction

This Application Note is required to perform a 1ENG, 1/3ENG and 1ENF transient vibration surveys on a PT6A/B engines. This Application Note describes the steps necessary for set up and operation of the Viper 4040 analyzer and associated equipment.

**Required Equipment:** The following equipment is required to accomplish this survey.

Item	Quantity	Description	Part Number
1.	1EA	ANALYZER, VIPER 4040	10-100-4040
2.	1EA	MOUNTS, SENSORS, VIBRATION, PWC (AGB) PWC50578 or PWC51495 and (RGB) PWC8052	
3.	2EA	SENSOR, VIBE, ACCEL, B&K 4505A	69-100-0023
4.	2EA	CABLE, MICRODOT-TO-BNC, 3 FT	75-200-0031
5.	2EA	CONVERTER, CHARGE, MODEL 510-2	10-100-1502
6.	2EA	CABLE, 510-2-TO-4040, 80 FT	10-320-0321
7.	2EA	GENERATOR, TACHOMETER, PWC N2	75-900-0001
8.	2EA	CABLE, TACH GENERATOR, 80 FT	10-320-0132
9.	2EA	CONDITIONING UNIT, SPEED, MODEL 516	10-100-1516
10.	2EA	CABLE, 516 TACH INTERFACE, 3 FT	10-320-0133

**Optional Equipment:** None

### Note

**You may choose to install the required items for both AGB and RGB vibration testing so as to complete both vibration tests without the necessity of uninstalling and reinstalling the equipment between test, or install only one and change the equipment for the second test.**

## A. Equipment Set Up

---

1. Install the required PWC vibration sensor mounts, item 2, at the appropriate locations IAW PWC maintenance manual.
2. Install the B&K 4505A accelerometers, item 3, on the sensor mounts, item 2, and torque per the instructions provided by the sensor specification sheet.
3. Install the microdot connector ends of the microdot-to-BNC cables, item 4, on the B&K4505A sensors, item 3.
4. Attach the BNC connector ends of the microdot-to-BNC cables, item 4, to the BNC connector ends of the 510-2 Charge Converters, item 5.
5. Attach the four pin end of the 80 ft 510-2-to-4040 cables, item 6, to the MS connector ends of the 510-2 charge converters, item 5. Secure the charge converters to the engine away from hot or moving parts using the provided tabs and wire ties.
6. Route the 80 Ft. 510-2 cables, item 6 to the location where the analyzer will be operated and connect the cable for the first test to be conducted (AGB or RGB) to the Viper 4040 Analyzer, item 1, at the CHANNEL A six pin vibration input.
7. Install the tachometer generators, item 7, on the engine according to maintenance manual instructions.
8. Attach the 80 Ft. tach generator cables, item 8, to the tachometer generators and to the 516 speed conditioners, item 9.
9. Connect the 516 Tach interface cables, item 10, to the 3 pin side of the 516 speed conditioning units, item 9, and the opposite end of the cables for the first test to be conducted (AGB or RGB) to the 4040 Viper Analyzer, item 1, at the TACH 1 input.

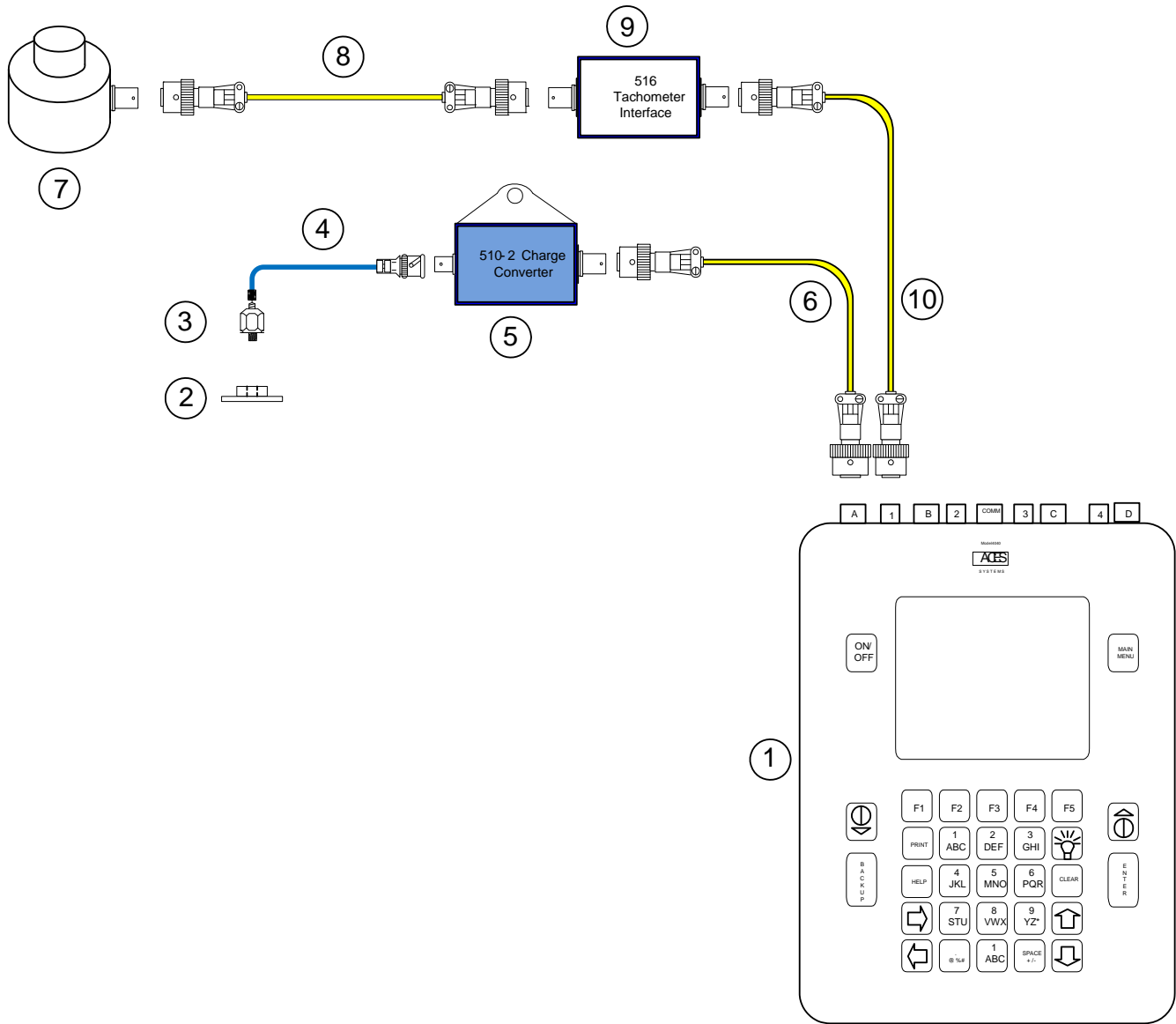

Figure 1. Equipment Installation

## B. Transient Vibration Survey Setup

---

### 10. Transient Vibration Survey Setup.

- 10.1 This section will give you the steps to enter the PT6A 1ENG Transient Vibration Survey Setup into the Viper Analyzer. If the setup for your model of PT6 has been previously entered, you need not repeat this step. If the setup is already entered, go to section B. Data Acquisition. Otherwise proceed to 10.2 below.

#### Note

You may optionally download all PT6 setup files from the ACES Systems web site <http://www.acesystems.com/esetups.htm> and transfer them directly to your analyzer from your PC using AvTrend software.

- 10.2 Turn the analyzer on by pressing the ON/OFF key.
- 10.3 From the Main Menu, select Miscellaneous Items.

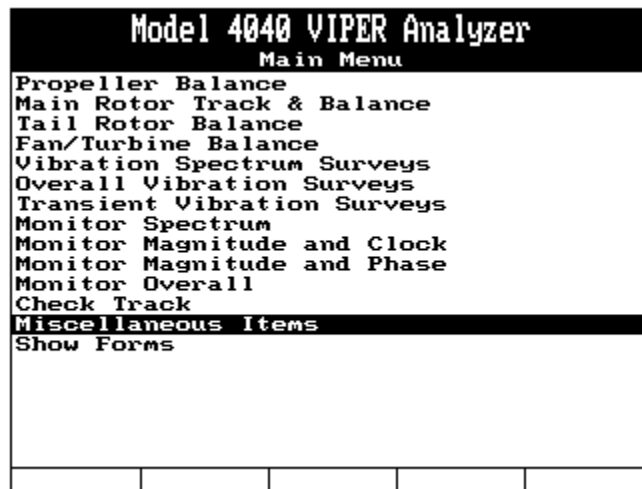

- 10.4 From the Miscellaneous Items menu, select "Setup Sensors".

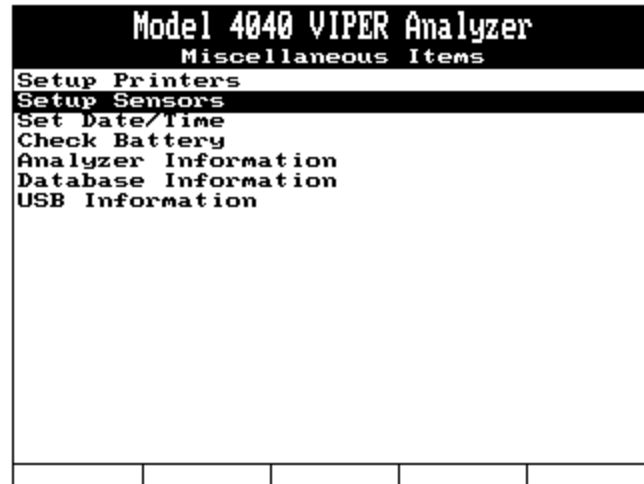

10.5 Complete the Sensor Setup screen, shown below, as follows:

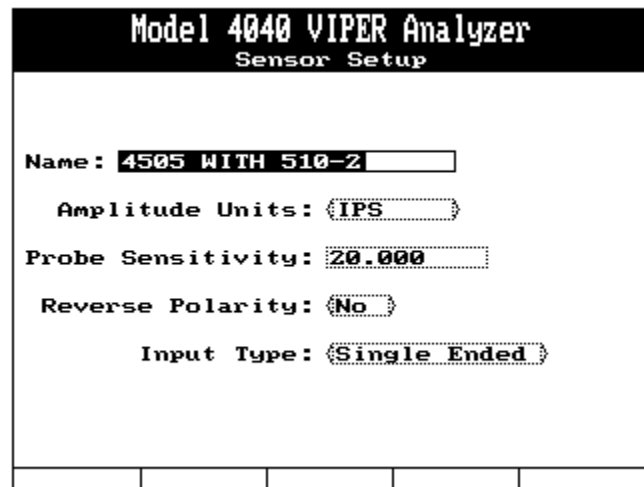

- 10.5.1 In the **Name:** field, enter “BK4505/510-2”. This will indicate this sensor is the B&K 4505 sensor with the ACES 510-2 charge converter. Press the ↓ key to move to the next field.
- 10.5.2 In the **Amplitude Units:** field, use the ⇒ key to select “IPS”. This is the engineering unit of output for the 4505 sensor being used with the 510-2 charge converter. IPS will be converted to cm/sec in the setup. Press the ↓ key to move to the next field.
- 10.5.3 In the **Probe Sensitivity:** field, enter “20”. This indicates the output of the 4505A sensor and 510-2 charge converter combination. Press the ↓ key to move to the next field.
- 10.5.4 In the **Reverse Polarity:** field, use the ⇒ key, if necessary, to select “No” indicating the sensor polarity is not reversed. Press the ↓ key to move to the next field.
- 10.5.5 In the **Input Type:** field, use the ⇒ key, if necessary, to select “Single Ended” indicating the type input from the sensor.

10.5.6 When all fields are complete, press ENTER to accept and save. The screen will return to the “Manage Sensors” screen. From that screen, press [BACKUP] repeatedly until the Main Menu is again displayed.

10.6 From the Main Menu, select “Transient Vibration Surveys” and press [ENTER].

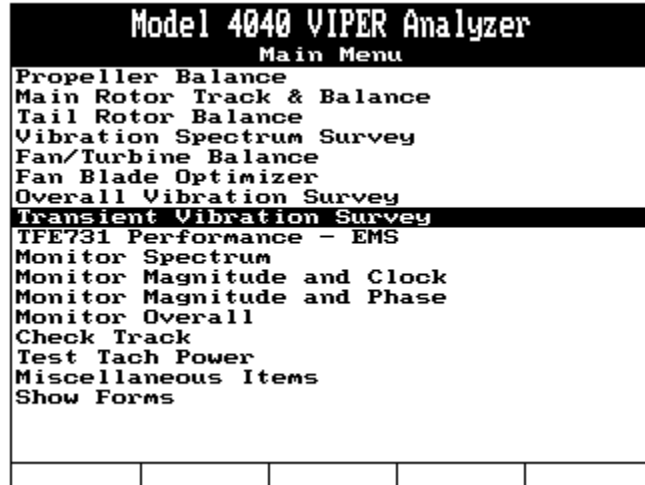

10.7 If there are setups already in the analyzer, the Setup List banner screen will be displayed. If the PT6 (+ sub model) 1ENG SURVEY is among those setups you need not repeat the following steps. Otherwise, from that screen, press the [F1] “New” key. If there are no setups in the analyzer, the “Transient Survey Setup” screen will be displayed automatically. Complete the Setup screen as follows:

10.7.1 Use the keypad to enter “PT6 (+submodel) 1ENG ” or “PT6(+submodel) 1ENF” in the **Name:** field. If the engine you are entering is PT6A-67B, -67D pr -64, and this is the AGB setup, also add “1/3ENG” to the end of the Name. For example “PT6A-67B 1ENG 1/3ENG”. Press the ↓ key to move to the next field.

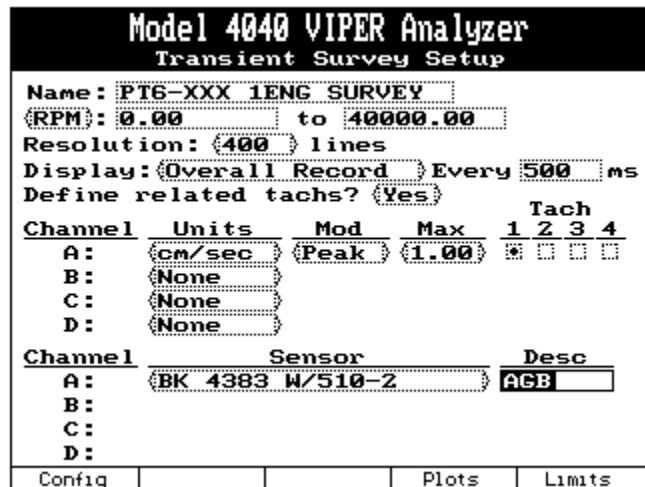

- 10.7.2 In the <RPM/Hz>: field, press the ⇒ key (if necessary) until the field reads “RPM”. Press the ↓ key to move to the next field.
- 10.7.3 In the unlabeled **Minimum frequency** field, the RPM will default to 0.00. Use the keypad to enter “0.00” RPM if necessary. Press the ↓ key to move to the next field.
- 10.7.4 In the unlabeled **Maximum frequency** field, use the analyzer keypad to enter the maximum turning speed you wish to monitor in either RPM or Hz as designated above in step 11.6.2. If this is the AGB setup, use “40000” for all models. If this is the RGB setup, use 30000 for models PT6A-45, -45A, -45B, -45R, -45AG, -50, -60, -60A, -65, -65B, 65R, -65ST, -65AR, -65AG, -67, -67A, -67B, -7D, -7B, 67D, -67R, -67AF, -67AG, -67CF and -67E. For all other models use 35000. Press the ↓ key to move to the next field.
- 10.7.5 In the **Resolution:** field, use the ⇒ key to select “400”. Press the ↓ key to move to the next field.
- 10.7.6 In the **Display:** field, use the ⇒ key to select “Overall”. Press the ↓ key to move to the next field.
- 10.7.7 In the **Every:**, use the analyzer keypad to enter “500”. Press the ↓ key to move to the next field.
- 10.7.8 In the “**Define related tachs?**” field, use the ⇒ key to toggle the answer to “YES”
- 10.7.9 In the **Units** column of the channel A: row, use the ⇒ key to select “cm/sec”. Press the ↓ key to move to the next field.
- 10.7.10 In the **Mod:** (Modifier) column of the Channel A: row, use the ⇒ key to select “RMS”. Press the ↓ key to move to the next field.
- 10.7.11 In the **MaxValue:** column of the Channel A: row, use the ⇒ key to select “1.00”. Press the ↓ key to move to the next field.
- 10.7.12 In the Tach 1 field, press the ⇒ key if necessary, to insert a black dot in the center of the square box immediately below the number “1”. Press the ↓ key to move to each of the remaining three Tach boxes (2, 3 and 4) and use the ⇒ key as necessary to leave the boxes below 2, 3 and 4 blank. Press the ↓ key repeatedly to move to the Sensor field.
- 10.7.13 In the **Sensor** column of the Channel A: row, use the ⇒ key to select “4505 WITH 510-2” sensor. Press the ↓ key to move to the next field.
- 10.7.14 In the **Desc** column for the Channel A: row, use the analyzer keypad to enter “AGB” or “RGB” according to which setup you are defining. Press the “Config” [F1] key.
- 10.7.15 The function keys at the bottom of the screen will change values. Press the [F1] “Conds” key.
- 10.8 The “Conditions” screen will be displayed. Complete each field in the screen as follows:

Model 4040 VIPER Analyzer		
Conditions		
Condition	Spectrum	Max. Time
1) ACCEL	Peak Hold	0
2) SHUTDOWN	Peak Hold	0
3) 1/3 ACCEL	Peak Hold	0
4) 1/3 SHUTDOWN	Peak Hold	0
5) █	None	0
6) █	None	0
7) █	None	0
8) █	None	0
9) █	None	0
10) █	None	0
11) █	None	0
12) █	None	0
13) █	None	0
14) █	None	0
15) █	None	0

- 10.8.1 In the **Condition** column, row 1), use the analyzer keypad to enter “ACCEL”. Press the ↓ key to move to the next field.
- 10.8.2 In the **Spectrum** column, row 1), use the ⇒ key to select “Peak Hold”. Press the ↓ key to move to the next field.
- 10.8.3 In the **Max. Time** column of row 1), you have two options. If you leave this value at “0” (zero), the analyzer will continue to take data for the condition until you press the [ENTER] key to stop it. If you enter a value higher than zero in this field, the analyzer will acquire data only for that number of seconds then terminate the data collection. Enter a number of seconds using the analyzer keypad or leave the field at zero per your requirements. Press the ↓ key to move to the next field.
- 10.8.4 In the **Condition** column, row 3), use the analyzer keypad to enter “SHUTDOWN”. Press the ↓ key to move to the next field.
- 10.8.5 In the **Spectrum** column, row 3), use the ⇒ key to select “Peak Hold”. Press the ↓ key to move to the next field.
- 10.8.6 In the **Max. Time** column of row 3), you have two options. If you leave this value at “0” (zero), the analyzer will continue to take data for the condition until you press the [ENTER] key to stop it. If you enter a value higher than zero in this field, the analyzer will take data only for that number of seconds then terminate the data collection. Enter a number of seconds using the analyzer keypad or leave the field at zero per your requirements.
- 10.8.7 If this setup is for PT6A-67B, -67D or -64, repeat steps 10.8.1 thru 10.8.6 twice with Condition labels of “1/3 ACCEL” and “1/3 SHUTDOWN”. All other settings remain the same. Press [ENTER] to continue.
- 10.9 The analyzer will return to the Transient Survey Setup screen. Again press the [F1] “Config” key. When the function keys change, press the [F2] “Speeds” key. Complete the Speed Inputs Setup as follows:

Model 4040 VIPER Analyzer				
Speed Inputs Setup				
	Measure	DESC	OFF/100%	Factor
1)	Pulse D-L	AGB	0.00000	2.97400
2)	None		0.00000	1.00000
3)	None		0.00000	1.00000
4)	None		0.00000	1.00000

Plot Info:			
	Min	Max	Div
1)	0.00	40000.00	8
2)	0.00	0.00	0
3)	0.00	0.00	0
4)	0.00	0.00	0

- 10.9.1 In row **1)** of the **Measure** column, use the ⇨ key to select “Pulse D-L” for the AGB test or “Pulse D-H” for the RGB test to indicate the speed input will be a pulse type differential signal and that the analyzer gain will be set to Low for the AGB or High for the RGB test. Press the ↓ key to move to the next field.
- 10.9.2 In the **DESC** (Description) field, use the analyzer keypad to enter “AGB or NG” for the AGB or “RGB or NF” for the RGB test. Press the ↓ key to move to the next field.
- 10.9.3 In the **OFF/100%** field, leave the setting at “0.00000”. This field is for a voltage offset value when using a voltage generator and is not applicable to the tach generator being used in this setup. Press the ↓ key to move to the next field.
- 10.9.4 In the **Factor** field, use the analyzer keypad to enter “2.97400” for the AGB or “2.64” for the RGB test. This ratio will produce an RPM value for the AGB or RGB according to this setting. Press the ↓ key repeatedly to move to the “Min” field in the Plot Info area.
- 10.9.5 In row **1)** of the **Min** column, use the analyzer keypad to enter “0.00”. Press the ↓ key to move to the next field.
- 10.9.6 In row **1)** of the **Max** column, use the analyzer keypad to enter 40000.00 if this is the AGB test. If this is the RGB test, enter 30000 for engine models PT6A-45, -45A, -45B, -45R, -45AG, -50, -50A, -60, -60A, -65, -65B, -65R, -65ST, -65AR or -65AG. All other models, enter 35000 for the RGB test. Press the ↓ key to move to the next field.
- 10.9.7 In row **1)** of the **Div** (Divisions) column, use the analyzer keypad to enter “8” if the Max setting reads “40000”, 7 if the Max setting reads “35000” or 6 if the Max setting reads 30000. This will divide the graph into equal blocks of 5,000 RPM each. Press [ENTER] to accept and continue.
- 10.10 The analyzer will return to the Transient Survey Setup screen. Again press the [F1] “Config” key. When the function keys change, press the [F3] “Pars” (Parameters) key. Complete the Transient Parameters Setup as follows:

Model 4040 VIPER Analyzer				
Transient Parameters Setup				
Description	Type	F(lower)	F(upper)	Speed
1ENG	Pwr	0.980	1.020	(xCS1)
1/3ENG	Pwr	0.320	0.350	(xCS1)
	Pwr	0.000	0.000	(xCS1)
	Pwr	0.000	0.000	(xCS1)
	Pwr	0.000	0.000	(xCS1)
	Pwr	0.000	0.000	(xCS1)
	Pwr	0.000	0.000	(xCS1)
	Pwr	0.000	0.000	(xCS1)
	Pwr	0.000	0.000	(xCS1)
	Pwr	0.000	0.000	(xCS1)
	Pwr	0.000	0.000	(xCS1)
	Pwr	0.000	0.000	(xCS1)
	Pwr	0.000	0.000	(xCS1)
	Pwr	0.000	0.000	(xCS1)
	Pwr	0.000	0.000	(xCS1)
	Pwr	0.000	0.000	(xCS1)
	Pwr	0.000	0.000	(xCS1)

- 10.10.1 In the first row of the **Description** column, use the analyzer keypad to enter “1ENG” for the AGB test or “1ENF” for the RGB test. Press the  $\downarrow$  key to move to the next field.
- 10.10.2 In the **Type** field, use the  $\Rightarrow$  key to select “Pwr” for power. Press the  $\downarrow$  key to move to the next field.
- 10.10.3 In the **F(lower)** field, use the analyzer keypad to enter “0.980”. This is the lower frequency multiplier of the speed tracking band width. Press the  $\downarrow$  key to move to the next field.
- 10.10.4 In the **F(upper)** field, use the analyzer keypad to enter “1.020”. This is the upper frequency multiplier of the speed tracking band width. Press the  $\downarrow$  key to move to the next field.

### Note

The tracking band width will be determined by multiplying the lower and upper factors (.98 to 1.02) times the current turning speed of the component being tracked, NG or NF. Vibration data occurring within this speed range will be recorded and vibration data outside this band width will be filtered out.

- 10.10.5 In the **Speed** column, press the  $\Rightarrow$  key to select (xCS1). This designates the computed speed 1 (from tach 1 input) as the speed source for tracking the AGB or RGB vibration. Press the  $\downarrow$  key to move to the next field.
- 10.10.6 Repeat steps 10.10.1 thru 10.10.5 using the example screen above to enter 1/3 ENG for the AGB test for engine models PT6A-67B, -67D and -64.. The **F(lower)** and **F(upper)** settings for the “1/3 ENG” are 0.320 to 0.350.
- 10.10.7 When all information is completed, press [ENTER] to accept and continue.
- 10.11 The analyzer will return to the Transient Survey Setup screen. Press the [F3] “Plots” key and complete the Transient Plots Setup screen as follows:

Model 4040 VIPER Analyzer		
Transient Plots Setup		
Parameter	Time	xCS1
Overall	Yes	Yes
1ENG	Yes	Yes
1/3ENG	Yes	Yes

- 10.11.1 Press the  $\downarrow$  key to move from field-to-field and press the  $\Rightarrow$  key to toggle between the YES and NO answers in each field. Select “Yes” for all plots you wish to view after the data is collected. When all settings are selected, press ENTER to accept and continue.
- 10.11.2 When the main transient setup is again displayed, press [ENTER] to store the setup in the analyzers memory. After the setup is stored you may turn the analyzer off or proceed to the Transient Vibration Survey procedure.

## C. Data Acquisition

---

11. Turn the analyzer ON by pressing the ON/OFF key momentarily.
- 11.1 Allow the analyzer to boot up to the main menu. From the main menu, use the  $\downarrow$  key to select “Transient Vibration Survey” and press [ENTER].

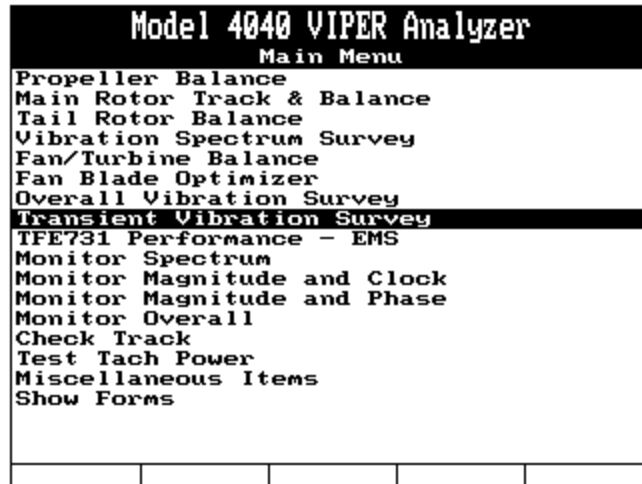

12. From the Transient Vibration Survey Jobs screen, select “Start Job” and press [ENTER].

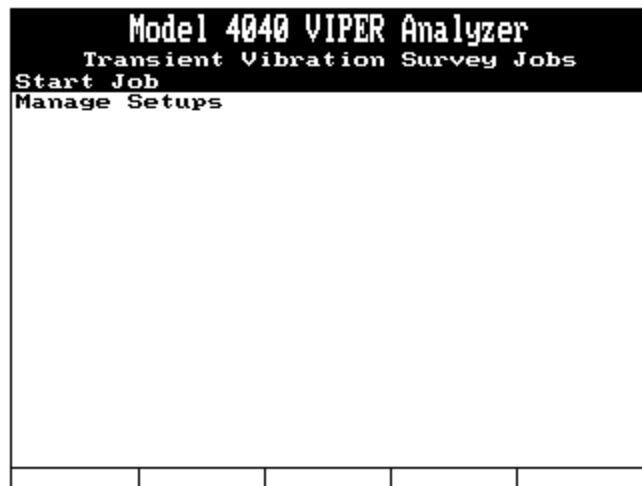

13. From the Setup list, select the 1ENG or 1ENF setup for the engine model on which you are conducting the test, then press [ENTER].

Select	
Setup List	
1)	PT6-67B 1ENF
2)	PT6-67B 1ENG 1/3ENG
3)	PT6A-60AG 1ENF
4)	PT6A-60AG 1ENG
5)	PT6A-62 1ENF
6)	PT6A-62 1ENG
7)	PT6A-64 1ENF
8)	PT6A-64 1ENG 1/3 ENG

New			Copy	
-----	--	--	------	--

14. All fields on this form are optional but completing them will assist in record keeping. In the Job Identification form, use the analyzer keypad to enter a Name for this job. This is usually the customers name but you may use what ever identifying name you wish. If Names have been entered into this analyzer previously, you may press the [F1] "Names" key and select the name from a list stored in the analyzer memory. Select the name using the arrow keys and press [ENTER] to insert the name into this form. Press the ↓ key to move to the next field.

Model 4040 VIPER Analyzer	
Job Identification	
Name:	Unnamed
A/C Registration:	
A/C Total Time:	0.0
Press ENTER to continue	
Names	

- 14.1 Use the analyzer keypad to enter the Aircraft Registration number. Press the ↓ key to move to the next field.
- 14.2 Use the analyzer keypad to enter the total aircraft time. When all fields are complete, press [ENTER] to accept and continue.
15. The Engine Information screen will be displayed. This too is an optional screen but filling in as many of the fields as possible will assist in record keeping.

- 15.1 In the “Position” field, press the  $\Rightarrow$  key to select the position of the engine on the aircraft (if applicable). Press the  $\Downarrow$  key to move to the next field.

The screenshot shows the 'Model 4040 VIPER Analyzer Engine Information' screen. The 'Position' field is set to '1'. Below it are sections for 'Propeller' and 'Engine', each with fields for 'S/N', 'Type', 'TSO', and 'TSN'. At the bottom, there is a table labeled 'Serial Nos' with four empty columns.

Serial Nos				

- 15.2 In the Propeller S/N (Serial Number) field, use the analyzer keypad to enter the serial number of the propeller (if applicable). Use the  $\Downarrow$  key to move to the next field.
- 15.3 In the Propeller Type field, use the analyzer to enter a descriptive name for the propeller such as brand or model number. Use the  $\Downarrow$  key to move to the next field.
- 15.4 In the TSO (Time Since Overhaul) and TSN (Time Since New) fields, use the analyzer keypad to enter a numeric value. Use the  $\Downarrow$  key to move to the next field.
- 15.5 Repeat 15.2 thru 15.4 above for the Engine information. When all fields are complete as necessary, press [ENTER] to accept and continue.
- 16 You may encounter an information message saying “Recovering Database Memory”. This is an information message only, not an error. Allow the process to complete. The analyzer will then display the Start Engine screen directing you to Perform FOD check, start the engine and establish normal operating conditions. When the engine is warmed up, press [ENTER] to continue.
- 17 The Select Condition screen will be displayed. Use the  $\Downarrow$  key to select ACCEL, SHUTDOWN, 1/3ACCEL or 1/3SHUTDOWN as appropriate. DO NOT PRESS ENTER until you are ready to begin the selected condition.
- 18 Refer to the PT6A manual for the requirements of each survey. Press [ENTER] to begin the data collection and [ENTER] a second time to terminate data collection. You will be asked “Save the data?” Whereby you must select [F1] for YES or [F5] for NO. When data collection is complete, transfer the collected data to AvTrend for viewing, printing or transferring to another facility via email.