



Application Note

Engine Type : TFE731-20

Procedure : Engine Vibration Survey

Part Number: 11-200-0138

AppNote Number: E-HO-TFE731-20-4040-VI

This Application Note is provided for information only and does not supercede the requirements or guidelines set forth in the applicable engine or airframe maintenance manual. Technology for Energy Corporation assumes no obligation or liability, either express or implied, to the Purchaser arising out of the use of this procedure.

Copyright © 2002, TEC Aviation Division. All rights reserved. This document is to be printed and reproduced for personal use only.



Application Note

Application Note Number	E-HO-TFE731-20-4040-VI
Version	1.0
Function	Engine Vibration Survey
Airframe	Various
Engine	TFE731-20
E-Setup Number	E-HO-TFE731-20-4040-VI
ACES Systems Analyzer	Viper 4040
Firmware Version	1.04 or Higher
Procedure	N/A

Introduction

This Application Note is required to perform an engine vibration survey on all airframes with TFE731-20 engines. This Application Note describes the steps necessary setup the equipment and the analyzer

Required Equipment: The following equipment is required to accomplish a single engine fan trim balance.

Item	Quantity	Description	Part Number
1.	1EA	Analyzer, Viper 4040	10-100-4040
2.	1EA	CABLE, VIBE, 6 PIN GENERIC, 50 Ft.	10-320-0127
3.	1EA	INTERFACE, 991V, GEN VIBE CABLE	10-320-0142
4.	1EA	MOUNT, SENSOR, TFE731-20 (Honeywell PN 5837035-1)	22-430-0073
5.	1EA	SENSOR, VIB, ACCEL, 4382, B&K	69-100-0033
6.	1EA	CONVERTER, CHARGE, 510-2	10-100-1502
7.	1EA	CABLE, SENSOR, MICRODOT-TO-BNC, 3 Ft.	75-200-0031

Optional Equipment: The following items are optional sensor and sensor interface cables. You may choose either sensor and interface combination. if you are conducting a dual engine job, double the number of items 2 thru 7 above. The 4382 and 4383 sensors are identical in performance. The 4382 has a top mounted connector and the 4383 a side mounted connector.

8.	1EA	SENSOR, VIB, ACCEL, 4383, B&K	69-100-0034
----	-----	-------------------------------	-------------

A. Equipment Set Up

1. Install the vibration sensor mount, item 4, on the engine support housing at one of the locations shown in the figure below.

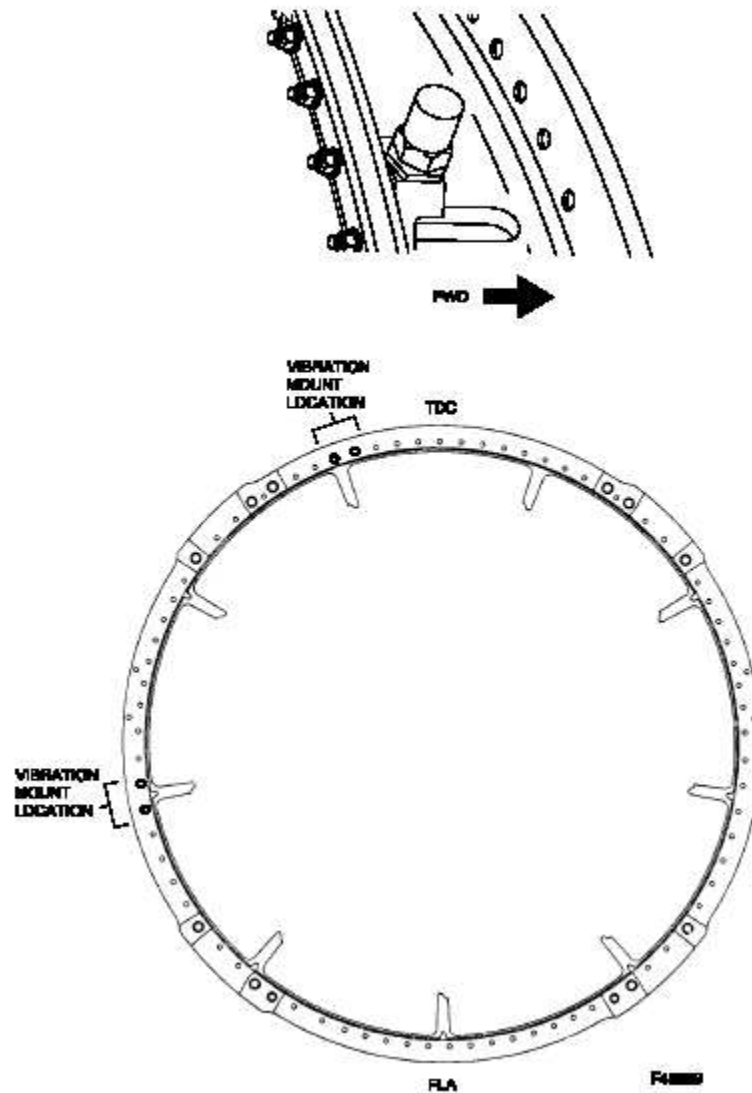

2. Install the vibration sensor, item 5 or 8, on the vibration sensor mount. Be sure the sensor is perpendicular to the center of the engine.
3. Connect the microdot end of the microdot-to-BNC cable, item 7, interface cable, to the selected sensor, item 5 or 8.
4. Connect the BNC end of the microdot-to-BNC cable, item 7, to the BNC input end of the 510-2 Charge Converter, item 6.

5. Connect the 4 pin socket end of the 991V-to-Generic Vibe cable Interface, item 3, to the MS connector end of the 510-2 Charge Converter, item 6. Connect the opposite end of the 991V-to-Generic Vibe Interface, item 3, to the socket end of the Generic Vibe Cable, item 2.
6. Route the Generic Vibe Cable, item 2, to the cockpit or position where the analyzer will be located. Avoid hot areas and high voltage components in the routing of all cables. Secure the cable to the fuselage every 36 inches with duct or speed tape to avoid movement or possible ingestion into the engine.
7. Connect the Generic Vibe Cable, item 2, to the Channel A vibration input of the 4040 Analyzer, item 1.

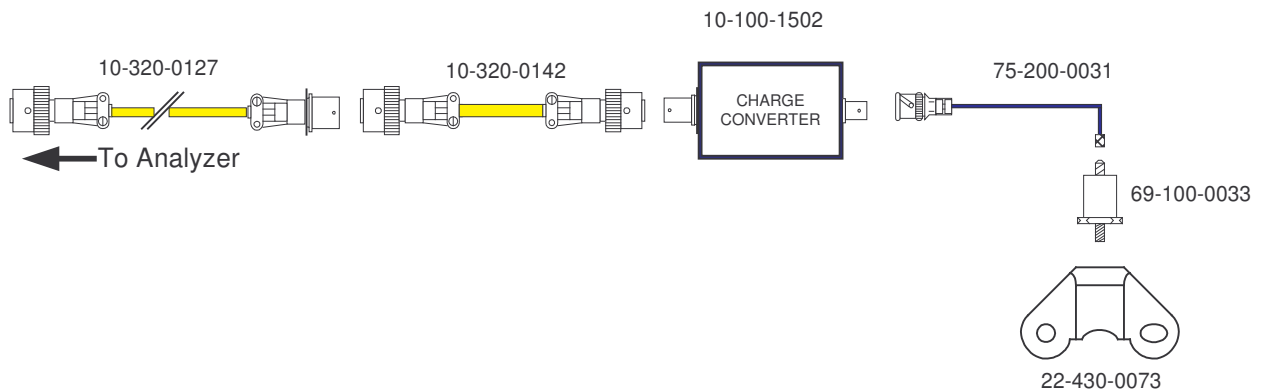
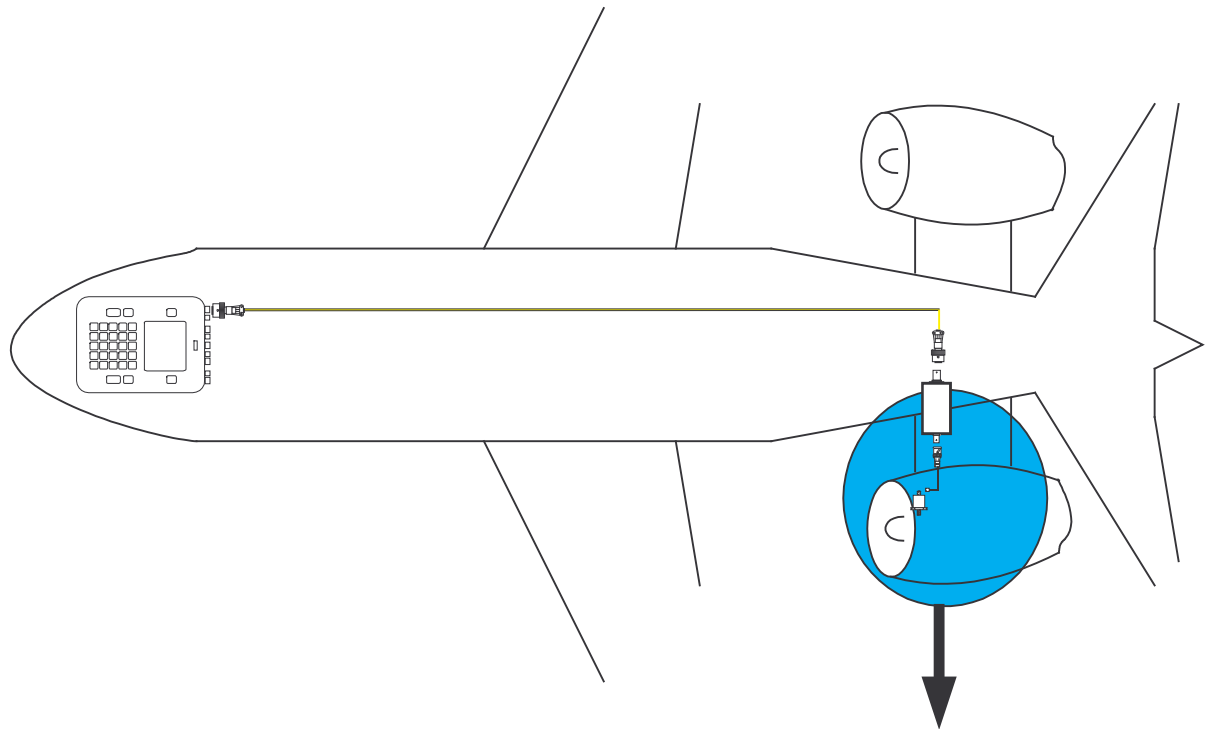

B. Analyzer Set Up

8. **Engine Vibration Survey Setup.**
9. This section will provide you with the steps to enter the Setup into the Viper Analyzer. If the setup has been previously entered, you need not repeat this step. If the setup is available, go to section C. Data Acquisition. Otherwise proceed to item 12 below.
10. Turn the analyzer on by pressing the ON/OFF key.
11. The analyzer has several default sensors already in memory. Other sensors may have also been programmed into the analyzer. To view the list of sensors already stored in the analyzers memory, do the following:
12. From the Main Menu, select Miscellaneous Items.

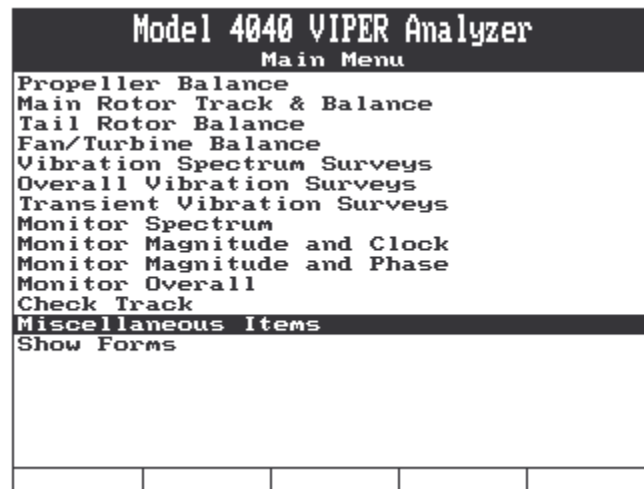

13. From the Miscellaneous items menu, select Setup Sensors, then press [ENTER].

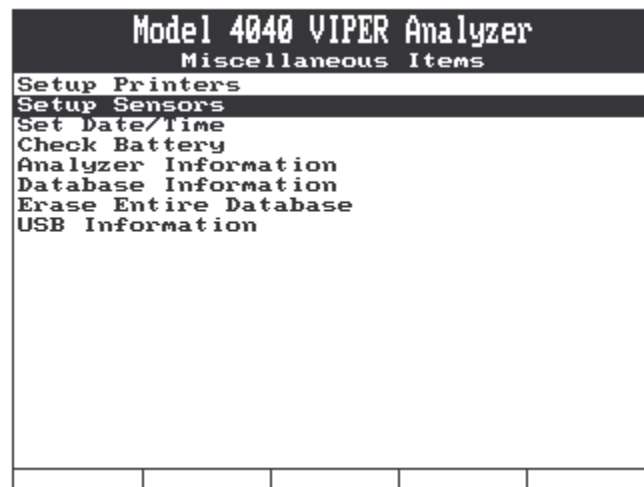

14. From the Manage Sensors menu, select Edit, then press [ENTER].

Model 4040 VIPER Analyzer				
Manage Sensors				
Edit				
New				
Print				
Print All				
Delete				

15. The Select menu will be displayed which lists all sensors currently programmed into the analyzers memory. If the sensor you are using is listed, you need not re-enter it. Go to item 22. Otherwise press the [BACKUP] key, select New from the Manage Sensors menu and proceed with item 21 below.

Select				
1)	793		
2)	AS907 ONBOARD		
3)	991D-1		
4)	991V		
5)	797V		
6)	BK 4383 W/510-2		
7)	CH 7310		
		New		

16. Complete the Sensor Setup screen, shown below, as follows:

In the **Name:** field, enter the sensor name (4382 w/510-2 for instance) Press the ↓ key to move to the next field.

Model 4040 VIPER Analyzer
Sensor Setup

Name: 4382 w/510-2

Amplitude Units: IPS

Probe Sensitivity: 200.000

Reverse Polarity: No

Input Type: Single Ended

In the **Amplitude Units:** field, use the \Rightarrow key to select units for the sensor. This is the engineering unit of output for the sensor such as g.'s for an accelerometer or IPS for a velocity sensor. For the 4382 w/510-2, select "IPS". Press the \downarrow key to move to the next field.

In the **Probe Sensitivity:** field, enter the mV per engineering unit as specified on the data sheet for the sensor you are using. For the 4382 w/510-2, enter 200. Press the \downarrow key to move to the next field.

In the **Reverse Polarity:** field, use the \Rightarrow key, if necessary, to select "Yes or No" as appropriate for the sensor you are using. For the 4382 w/510-2, this will be "No" indicating the sensor polarity is not reversed. Press the \downarrow key to move to the next field.

In the **Input Type:** field, use the \Rightarrow key, as necessary, to select "Differential or Single Ended" indicating the type input to the sensor. For the 4382 w/510-2, this will be Single ended.

When all fields are complete, press [ENTER] to accept and save. The screen will return to the "Manage Sensors" screen. From that screen, press [BACKUP] repeatedly until the Main Menu is again displayed.

17. From the Main Menu, select Vibration Spectrum Surveys and press [ENTER].

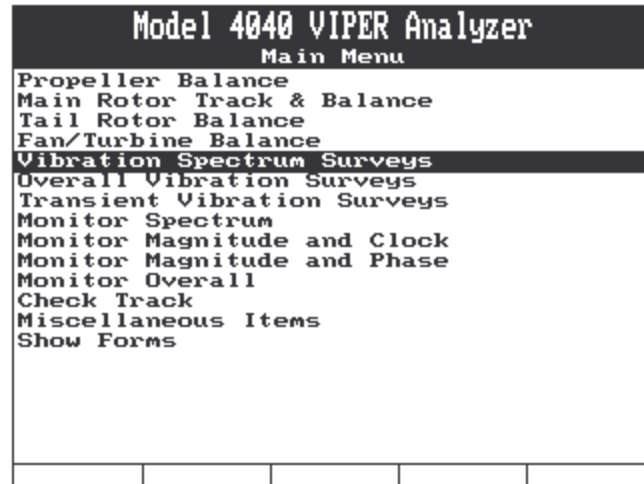

18. From the Jobs and Setups Menu, select Start Job, and press [ENTER]

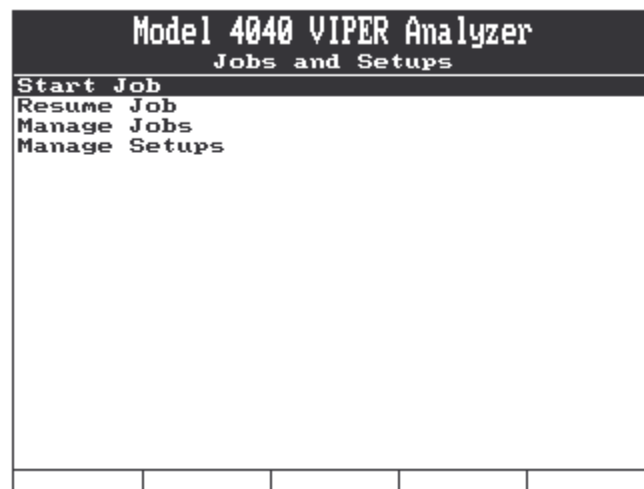

19. If other setups have previously been entered in this analyzer, a Setup List will be displayed from which you may select a setup to use. Check to see if the TFE731-20 setup is among them. If it is, you may select it and continue with section C, DATA ACQUISITION of this document. If it is not among the listed setups, press the [F1] "New" key and proceed to step 13 below. If no setups have been previously entered in this analyzer, the Spectra Setup screen will be automatically displayed and you may proceed to step 13 below.

Select Setup List				
1 > 8044 TEST				
New			Copy	

20. In the Spectra Setup screen complete each field as follows:

- 20.1 In the **Name** field, use the analyzer keypad to enter “TFE731-20 ENG SURVEY”. Press the [↓] key to move to the next field.
- 20.2 In the **Minimum Frequency** field, use the analyzer keypad to enter “1200”. Press the [↓] key to move to the next field.
- 20.3 In the **Maximum Frequency** field, use the analyzer keypad to enter “60000”. Press the [↓] key to move to the next field.
- 20.4 Use the [←] and [→] keys to select <RPM> in the frequency field. Press the [↓] key to move to the next field.
- 20.5 In the **Resolution** field, use the [←] and [→] keys to select <400>. Press the [↓] key to move to the next field.
- 20.6 In the **Blocks In Average** field, use the analyzer keypad to enter “4”. Press the [↓] key to move to the next field.
- 20.7 In the Sensor field, Channel A row, use the [←] and [→] keys to select the sensor you are using for this survey. If your sensor is not among the available selections, refer to step 9 of this section above to enter your sensor. Press the [↓] key to move to the next field.
- 20.8 In the **Desc** (Description) field, use the analyzer keypad to enter a description of the channel A sensor. In the example below we have entered the clock position of the sensor. Press the [↓] key repeatedly to move to the **Vibration** field.
- 20.9 In the **Vibration** field, use the [←] and [→] keys to select “IPS” for Inches Per Second. Press the [↓] key to move to the next field.
- 20.10 In the **Modifier** field, use the [←] and [→] keys to select “Peak”. Press the [↓] key to move to the next field.

- 20.11 In the **Full Scale Vibration** field, use the [⇐] and [⇒] keys to select the highest amplitude you expect to encounter during the survey. In normal circumstances, 1 or 2 will suffice for the TFE731.

Model 4040 VIPER Analyzer
Spectra Setup

Name: **TFE731-20 ENG SURVEY**
 Minimum Frequency: **1200.00**
 Maximum Frequency: **60000.00** (RPM)
 Resolution: **400** lines
 Average Type: **Peak**
 Blocks in Average: **4**

Channel	Sensor	Desc
A:	4382 w/510-2	2.00
B:	None	
C:	None	
D:	None	

Vibration: **IPS**
 Modifier: **Peak**
 Full Scale Vibration: **2.00**

Edit Conds | Speeds | Limits | |

21. When all fields in the above screen are set, press the [F3] “Limits” key. The function fields (directly above the five function keys) will change to the configuration shown in the example screen below. If you are using a single channel to collect the vibration survey, press the [F1] “A-Limits” key.

Model 4040 VIPER Analyzer
Spectra Setup

Name: **TFE731-20 ENG SURVEY**
 Minimum Frequency: **1200.00**
 Maximum Frequency: **60000.00** (RPM)
 Resolution: **400** lines
 Average Type: **Peak**
 Blocks in Average: **4**

Channel	Sensor	Desc
A:	4382 w/510-2	2.00
B:	None	
C:	None	
D:	None	

Vibration: **IPS**
 Modifier: **Peak**
 Full Scale Vibration: **2.00**

A-Limits | B-Limits | C-Limits | D-Limits | Back

- 21.4 Complete the **Edit Limits for Channel A:** screen as follows:
- 21.4.1 In the **F-low** (Frequency – low) field for row 1, the frequency will be defaulted to “0.00”. Leave this field in the default 0.00 and press the [↓] key to move to the next field.
- 21.5 In the **F-high** (Frequency – high) field for row 1, use the analyzer keypad to enter “11700”. Press the [↓] key to move to the next field.
- 18.4.1 In the **Unit** field for row 1, use the [⇐] and [⇒] keys to select “xRPM”. Press the [↓] key to move to the next field.

- 21.5.2 In the **Limit** field for row 1, use the analyzer keypad to enter .15. Press the [↓] key to move to the next field.
- 21.5.3 In the **F-low** field for row 2, use the analyzer keypad to enter 11700. Press the [↓] key to move to the next field.
- 21.5.4 In the **F-high** field for row 2, use the analyzer keypad to enter 60000. Press the [↓] key to move to the next field.
- 21.5.5 In the **Unit** field for row 2, use the [⇐] and [⇒] keys to select “xRPM”. Press the [↓] key to move to the next field.
- 21.5.6 In the **Limit** field for row 2, use the analyzer keypad to enter 0.70. Press the [↓] key to move to the next field.

Model 4040 VIPER Analyzer				
Edit Limits for Channel A: 2.00				
	F-low	F-high	Unit	Limit
1)	0.00	11700.00	xRPM	0.15
2)	11700.00	60000.00	xRPM	0.70
3)	0.00	0.00	xCS1	0.00
4)	0.00	0.00	xCS1	0.00
5)	0.00	0.00	xCS1	0.00
6)	0.00	0.00	xCS1	0.00
7)	0.00	0.00	xCS1	0.00
8)	0.00	0.00	xCS1	0.00
9)	0.00	0.00	xCS1	0.00
10)	0.00	0.00	xCS1	0.00
11)	0.00	0.00	xCS1	0.00
12)	0.00	0.00	xCS1	0.00
13)	0.00	0.00	xCS1	0.00
14)	0.00	0.00	xCS1	0.00
CopyToAll		CopyToB	CopyToC	CopyToD

15. Press the [ENTER] key when the Spectra Setup screen, shown below is again displayed to accept your settings and continue.

Model 4040 VIPER Analyzer			
Spectra Setup			
Name:	TFE731-20 ENG SURVEY		
Minimum Frequency:	1200.00		
Maximum Frequency:	50000.00	(RPM)	
Resolution:	400 lines		
Average Type:	Peak		
Blocks in Average:	4		
Channel	Sensor	Desc	
A:	4382 w/510-2	2.00	
B:	None		
C:	None		
D:	None		
Vibration:	IPS		
Modifier:	Peak		
Full Scale Vibration:	2.00		
Edit Conds	Speeds	Limits	

16. When the Customer Information screen, shown below, is displayed. At this time you may turn the analyzer off or continue. Complete the optional fields using the keypad. Move from field to field using the [↓] key. While the cursor is in the **Name** field, you may press the [F1] “Names” key and select a name from a list of previously entered names. Press [ENTER] to accept your inputs and continue.

Model 4040 VIPER Analyzer			
Customer Information			
Enter the following optional Customer information.			
Name:	<input type="text"/>		
A/C Registration:	<input type="text"/>		
A/C Total Time:	0.0		
Press ENTER to continue			
Names			

17. The Engine Information screen, shown below, will be displayed. Complete the optional fields using the keypad. Move from field to field using the [↓] key. While the cursor is in the **SN** field, you may press the [F1] “Serial Nos” key and select a serial number from a list of previously entered numbers. Press [ENTER] to accept your inputs and continue.

Model 4040 VIPER Analyzer				
Engine Information				
Position:				
1				
Propeller:				
S/N				
Type				
TSO	0			
TSN	0			
Engine:				
S/N				
Type				
TSO	0			
TSN	0			
Serial Nos				

C. Data Acquisition

18. The information screen below will be displayed directing you to Start the Engine and Establish Normal Operating Conditions. At this time you should start the engine per normal procedures. Calculate the N1 for the day while the engine warms up. When the engine is at normal operating temperatures, press the [F5] “Continue” key.

Model 4040 VIPER Analyzer				
Start Engine				
<p>Start the Engine and Establish Normal Operating Conditions.</p>				
				Continue

19. After pressing the “Continue” key from the screen above, a STANDBY information, shown below, will be displayed. Do not accelerate the engine while this screen is displayed. Wait for the STANDBY screen to extinguish and be replaced by the spectrum.



- 19.1 When the spectrum, shown below, is displayed, begin a slow acceleration (not less than 60 seconds) to N1 for the day. When you reach N1 for the day, allow the engine to stabilize for a few seconds then press [ENTER] to stop the data collection.

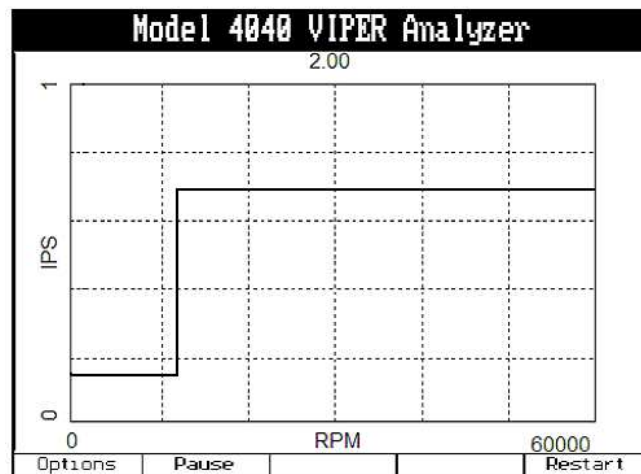

20. The information screen below will be displayed asking “Store Data?” If you wish to store the data just collected, press the [F1] “Yes” key and the data will be stored in the analyzers memory. If you do not wish to save the data, press the [F5] “No” key and the data will be discarded. Remember that if you choose the No option, the data cannot be recovered.

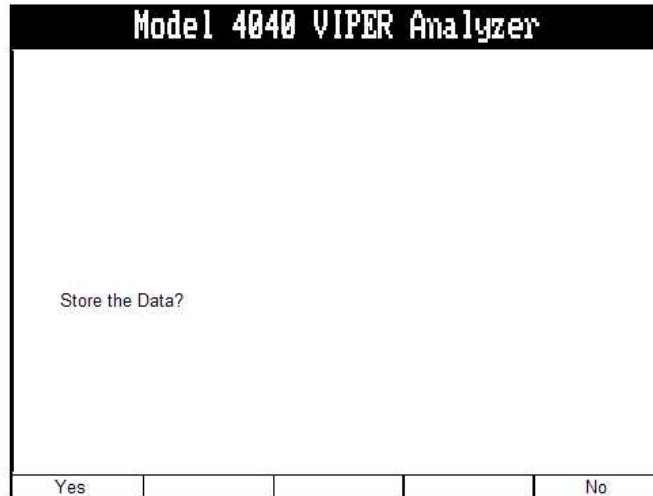

21. The next screen displayed will be the Shutdown screen shown below. As indicated, the requirements for the Survey are complete and you should now Perform a Normal Shutdown of the engines. Press the [F5] key to acknowledge and Continue. This terminates the job. If you wish to review the survey you may do so by accessing the Manage Jobs | Review function of the Vibration Spectrum feature. Refer to the 4040 or AvTrend users manual for printing the survey.

