



Application Note

TFE731 Series Engines

Five Point Performance Run using EMS

Part Number: 11-200-XXXX

AppNote Number: E-HO-TFE731-1700/1752B-PE

This Application Note is provided for information only and does not supercede the requirements or guidelines set forth in the applicable engine or airframe maintenance manual. Technology for Energy Corporation assumes no obligation or liability, either express or implied, to the Purchaser arising out of the use of this procedure.

Copyright © 2001, TEC Aviation Division. All rights reserved. This document is to be printed and reproduced for personal use only.



Application Note

Application Note Number	E-HOTFE731-1700 /1752B-PE
Version	2.0
Function	TFE731 Performance
Airframe	Various
Engine	TFE731 (All Models)
Other Application Notes Required	NONE
ACES Systems Analyzer	1700 or 1725 Analyzer / 1752B Mini JEDA
Firmware Version	2.08C or higher
Procedure Cards	TFE731 EMS

Introduction

This Application Note is required to conduct a performance run on various aircraft with Honeywell TFE731 turbofan engines equipped with EEC, N2 DEEC, or N1 DEEC Computers. This Application Note describes the steps necessary for set up and operation of the ACES 1700 or 1725 analyzer in conjunction with the model 1752B Mini JEDA.

This application note is provided for information only and does not supercede the requirements or guidelines set forth in the applicable engine or airframe maintenance manual. Technology for Energy Corporation assumes no obligation or liability either express or implied, to the Purchaser arising out of the use of this procedure.

Equipment Set Up

Required Equipment: The following equipment is required to accomplish a single engine performance run using the ACES 1700 Analyzer Plus and 1752B Mini JEDA.

Item	Quantity	Description	Part Number
1.	1EA	1700 Analyzer Plus (Analyzer Only)	10-100-1700
2.	1EA	1752B Mini JEDA	10-100-1752B
3.	1EA	Software, JEDA Comm for Windows	10-700-0023
4.	1EA	Procedure, TFE731 EMS	11-100-0104
5.	1EA	Cable, Comm, N1 DEEC, uJEDA, J1 Standard	10-320-0267
6.	1EA	Cable, JEDA Comm, RS422	10-320-0258
7.	1EA	Sensor Assembly, RTD Ambient Temp	10-100-0214

8.	1EA	Cable, Ambient Temperature	10-320-0232
9.	1EA	Converter., RS232-to-RS422, 25 Pin	75-210-0058

Optional Equipment: The following items are optional.

10.	1EA	Analyzer, ACES 1725 Trim TEC (In place of 1700 above)	10-100-1725
11.	1EA	Cable, Comm, N1 DEEC, Lear 45	10-320-0273
12.	1EA	Cable, Comm, N1 DEEC, Falcon 900EX /	10-320-0275
13.	2EA	Cable, Pressure Transducer, Amb.	10-320-0262
14.	1EA	Transducer, AMB Pressure	10-100-0355
15.	2EA	Cable, Pressure Transducer, 2.35/3.0 , 1.5 ft.	10-320-0241
16.	1EA	Transducer, 2.35 Pressure	10-100-0356
17.	1EA	Transducer, 3.0 Pressure	10-100-0357
18.	1EA	Mount, Pressure Transducer, Mini JEDA	22-900-0087
19.	1EA	Adapter, DB25F-to-DB9F	75-800-0016
20.	1EA	Cable, 2.35 Temp, 25 ft.	10-320-0242
21.	1EA	Cable, 3.0 Temp, 25 ft.	10-320-0243
22.	1EA	Cable, Fuel Flow, 25 ft.	10-320-0231
23.	1EA	Cable, Fuel Temp, 25 ft.	10-320-0233
24.	1EA	Meter, Fuel Flow	54-200-0001
25.	1EA	Probe, RTD Fuel Temp	10-100-0121
26.	2EA	Hose, 2.35 / 3.0 Pressure Transducer, 12 ft.	10-100-0349
27.	1EA	Cable, Comm, N1 DEEC, Falcon 50 (side engines only)	10-320-0288
28.	1EA	Cable, Comm, N1 DEEC, Falcon 50 (center engine only)	10-320-0287
29.	1EA	Cable, Comm, N1 DEEC, (-60 and -62 computers only)	10-320-0274
30.	1EA	CABLE, EEC COMPUTER-TO-JEDA, 10 FT	10-320-0238
31.	1EA	CABLE, N2 DEEC COMPUTER-TO-JEDA, 10 FT	10-320-0239

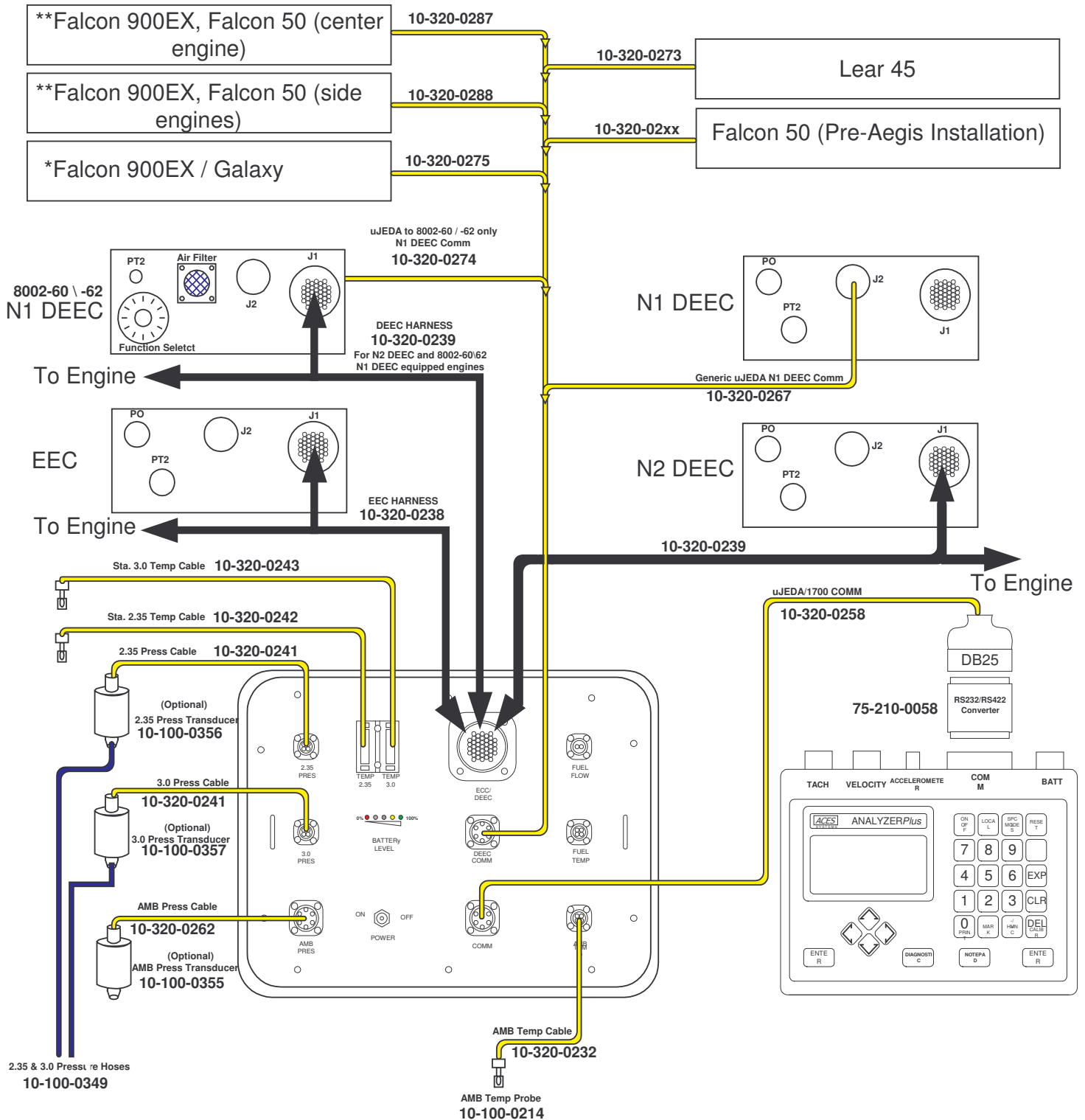

**SN 88 and higher only
*SN 87 and lower only

**1752B JEDA with 1700 Analyzer Plus
Equipment Setup**

1. Preparation:

- 1.1 Insure the 17xx Analyzer and 1752B JEDA batteries are fully charged and that the latest version of the EMS procedure is loaded into the analyzers memory.
- 1.2 Insure power to the Jeda, Analyzer, and N1 DEEC Computer are OFF prior to making any connections.
- 1.3 Select the correct N1 DEEC comm cable for the aircraft you running (see the required and optional equipment list above).
- 1.4 If possible, position aircraft in the runup area prior to equipment setup
- 1.5 Ground the aircraft if possible to avoid static discharge and associated damage to the Jeda unit

2. Setup

- 2.1 Connect the JEDA / DEEC comm cable, item 5, 11, 12, 27, 28, or 29 to the N1 computer for the selected engine / airframe application. This cable will be one of six variants, a generic N1 DEEC, item 5, Learjet 45, item 11, Falcon 900EX / Gulfstream G200, item 12, Falcon 50 (side engine), Falcon 50 (center engine) or any aircraft equipped with 8002-60 or 8002-62 N1 computers. The generic N1 DEEC connects to the J2 connection of the standard N1 computer, the other variants connect to the airframe specific interface connection.

NOTE

If you are conducting a performance run on aircraft equipped with 8002-60 or 8002-62 N1 computers, you must use both the N1 DEEC Comm cable 10-320-0274 to control the computer AND the N2 DEEC Harness 10-320-0239 to download information from the N1 computer. (See the drawing above on page 3.)

- 2.2 Connect the opposite end of the N1 DEEC comm cable, item 5, 11, or 12, to the JEDA, item 2, at the “DEEC COMM” connector.
- 2.3 Connect the Ambient Temp cable, item 8, to the “AMB TEMP” connector of the JEDA unit, item 2. Connect the RTD AMB Temp Sensor, item 7, to the opposite end of the cable and place the RTD Ambient Temp sensor, item 7, in an area which will not be exposed to direct sunlight but will approximate the ambient conditions of those near the engine inlet. Secure the cable and temp probe to avoid possible injection into the engine and to prevent movement which may damage the sensor or the aircraft finish.
- 2.4 If using the optional AMB Pressure transducer, item 14, attach it to the Pressure Transducer Mount, item 18.. Attach the AMB Press cable, item 13, to the AMB Pressure Transducer, item 14, connector and to the AMB PRESS connector of the JEDA, item 2.
- 2.5 If using the optional 2.3 Pressure transducer, item 16, attach it to the Pressure Transducer Mount, item 18. Attach a 2.35/3.0 Press cable, item 15, from the 2.3 Pressure Transducer, item 16, connector and to the 2.3 PRESS connector of the JEDA, item 2. Attach a Pressure Hose, item 26 to the pressure fitting of the Transducer and to station 2.35 pressure source.

- 2.6 If using the optional 3.0 Pressure transducer, item 17, attach it to the Pressure Transducer Mount, item 18, then hang the mount on the Jeda case. Attach a 2.35/3.0 Press Transducer Cable, item 15, from the 3.0 Pressure Transducer, item 17, connector and to the 3.0 PRESS connector of the JEDA, item 2. Attach a Pressure Hose, item 26 to the pressure fitting of the Transducer and to station 3.0 pressure source.
- 2.7 When all transducers being used are connected per items 2.4 through 2.6 above, hang the Pressure Transducer Mount, item 18, on the left side of the JEDA case adjacent to the three pressure connectors of the JEDA. Because the AMB pressure transducer is capable of being physically seperated from the JEDA unit by a larger distance, the AMB pressure transducer cable is manufactured longer. The 2.35 and 3.0 transducers do not have this capability and **MUST** be no farther away from the JEDA unit than the 2.35/3.0 Pressure Transducer cables, item 15 allow. **DO NOT MODIFY OR LOCALLY MANUFACTURER THESE CABLES** to accommodate a greater distance from the JEDA unit than the original design.

- 2.8 Connect the JEDA-to1700 comm cable, item 6, to the COMM connector of the JEDA, item 2. Attach the 25 Pin DB connector end of the cable to the RS232-to-RS422 converter, item 9, at the end marked “RS422”. Connect the opposite end, marked “RS232”, of the RS422 convereter, item 9, to the DB25 serial COMM port of the 1700 analyzer, item 1. If using the optional 1725 Trim TEC analyzer, item 10,you must use a DB25F to DB9F adapter, item 19, between the RS232-to-RS422 converter and the 1725 analyzer’s DB9 serial comm port.
- 2.9 If you will taxi or tow the aircraft with the equipment installed, be sure all cables as well as the JEDA unit are secured prior to aircraft movement. You may start engines normally after the equipment installation is complete.
- 2.10 If using the optional Fuel Flow Meter, item 24, install it with straightening tubes into the fuel supply line. Connect the Fuel Flow cable, item 22, to the fuel flow meter, item 24. Route the cable to the JEDA unit, item 2, and attach to the FUEL FLOW connector.
- 2.11 If using the optional Fuel Temp Probe, item 25, install the probe into a wrenching flat of the AN8 coupling. Connect the Fuel Temp Cable, item 23 to the connector of the Fuel Temp Probe, item 25 and route the cable to the JEDA unit, item 2 and attach to the FUEL TEMP connector.
- 2.12 Secure all cables and equipment to avoid ingestion into the engine or damage to the aircraft finish.

B. Analyzer Set Up

1. Turn the 1752B JEDA power ON by placing the POWER switch to the [ON]position.
2. Turn the Analyzer ON by pressing the ON/OFF key.
3. When the Operation Options menu is displayed, select “TFE731 EMS” and press [ENTER].

```

-----| Fri 09Nov2001 10:43 3860Kb
ACES ANALYZER +
Operation Options
1--GE CF34 Vibration      v3.26
2--IFE731 EMS             v1.00
3--AV-8B-RRF402 Vib Surv v2.51
4--Acoustic Analysis     v2.51

Select Function Using ↑↓.

```

- The analyzer will conduct a short self test and display the current battery condition dependent on how long the analyzer has been idle. The screen will then automatically progress to the next screen.

```

----- Mon 19Nov2001 17:02 4240Kb
EMS
Battery Charge Is 100%

```

START

- When the EMS main menu is displayed, select “1—Start” and press [ENTER].

NOTE

The word “DEMO” in the banner, as seen below, will not be seen on the actual analyzer screen. This may be seen in various screens throughout this document because of the software utilized to generate the illustration screens.

```

----- Mon 19Nov2001 10:00 4325Kb
----- Performance DEMO
Page 1 of 2
1--Start
2--Review
3--Transfer To PC
4--Delete
5--Print
6--Communications Test
   [More]
Select Option

```

- The analyzer screen will display a momentary screen, shown below, while the system conducts a self check and determines the hardware configuration. The analyzer will automatically proceed to the next screen when the interrogation is complete. If an error is detected, this screen may be supplemented by an error message.

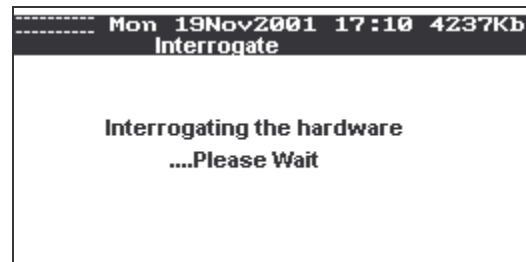

7. When the “Aircraft Select” banner screen is displayed, use the [RIGHT ARROW] or [LEFT ARROW] keys to select the aircraft (A/C) Model or use the [DIAGNOSTIC] key, for 1700, or the [ANALYZER] key, for 1725 to Exit back to the Main Menu. The selection of aircraft models is limited to those determined compatible with the detected hardware configuration.

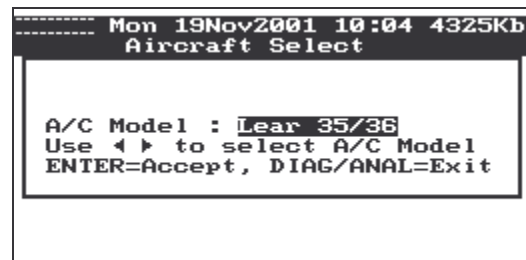

8. When the “Engine Select” banner screen is displayed, use the [RIGHT ARROW] or [LEFT ARROW] keys to select the Engine (Eng) Model, then press [ENTER] to accept or press the [DIAGNOSTIC] key, on 1700, or the [ANALYZER] key, on 1725, to Exit back to the Main Menu. The selection of engine models is limited to those determined compatible with the detected hardware configuration.

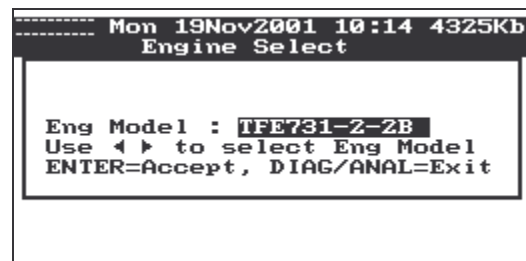

9. When the “Nozzle Select” banner screen is displayed, use the [RIGHT ARROW] or [LEFT ARROW] key to select the nozzle ID for the selected engine, then press [ENTER] to accept or press the [DIAGNOSTIC] key, on 1700, or the [ANALYZER] key, on 1725, to Exit back to the Main Menu.. If you are unsure of the nozzle type, select “Unknown”.

```

----- Mon 19Nov2001 10:22 4325Kb
      Nozzle Select

Nozzle: Lear Coamular
Use < > to select Nozzle ID
ENTER=Accept, DIAG/ANAL=Exit

```

10. After selecting the nozzle type, the matrix screen below will be displayed. Enter the optional Customer Name as follows:
- If a Customer Name is already in the field you may press [ENTER] to accept the name or [CLR] to clear the field and enter a new name.
 - Use the [ARROW] keys to navigate the matrix.
 - When the cursor is over the character you wish to insert, press [ENTER], then move to the next desired character. The blank space to the left of the “A” will insert a blank . Use the [DEL] key to clear the last character or the [CLR] key to clear the field.
 - When the name string is complete, press [NOTEPAD] for the 1700, or [BACKUP] for the 1725, to accept the string and continue.

```

----- Mon 19Nov2001 10:27 4325Kb
      Perf Calib Setup

Customer Name :

  ABCDEFGHIJKLMNO
  PQRSTUVWXYZ-+*/=
  0123456789(<>[]
  ?.,!@#$/^&_~'""
Enter Customer Name
Accept character with ENTER.
Accept string with BACKUP.

```

```

----- Mon 19Nov2001 11:13 4302Kb
      Perf Calib Setup

Customer Name :
JOHN JETSON
  ABCDEFGHIJKLMNO
  PQRSTUVWXYZ-+*/=
  0123456789(<>[]
  ?.,!@#$/^&_~'""
Enter Customer Name
Accept character with ENTER.
Accept string with BACKUP.

```

11. Enter the optional aircraft registration number in the same manner as the customer name above. When the registration number is complete, press [NOTEPAD] for the 1700, or [BACKUP] for the 1725, to accept the string and continue.

```

----- Mon 19Nov2001 12:27 4289Kb
Perf Calib Setup

Aircraft S/N:
N123JJ
      ABCDEFGHIJKL MN O
      PQRSTU VWXYZ - + * / =
      0 1 2 3 4 5 6 7 8 9 ( ) < > [ ]
      ? . , ! @ # $ % ^ & _ ` ~ ' " "
Enter Aircraft S/N
Accept character with ENTER.
Accept string with BACKUP.

```

12. The engine information screen below will be displayed. Complete the fields as follows:
- Enter the **Fuel Specific Gravity** at 60 degrees F (15.6 degrees C) using the numeric keypad. Move to the next field by pressing the [DOWN ARROW] key. This entry is only necessary if Fuel Flow and Fuel temperature is being measured.
 - Enter the **Fuel LHV (BTU/lbm)**, (Fuel Lower Heating Value (BTU per pound mass). Move to the next field by pressing the [DOWN ARROW] key. This entry is only necessary if Fuel Flow and Fuel temperature is being measured.
 - Select the desired **Temp Display Units** in degrees Centigrade or degrees Fahrenheit by pressing the [RIGHT ARROW] key to toggle between the two choices. Move to the next field by pressing the [DOWN ARROW] key.
 - Enter the desired **N1 Delta (rpm)**. This number defines the allowable variation of speed in rpm for acceptable data acquisition. The default is 100 and should not be reset to a higher value unless the urgency of the run dictates under less than desirable wind conditions. Move to the next field by pressing the [DOWN ARROW] key.
 - Select the **Reason** for this calibration performance run by pressing the [RIGHT ARROW] key until the desired reason is displayed. Move to the next field by pressing the [DOWN ARROW] key.
 - Enter the optional **Eng Hrs** (engine hours) from the numeric keypad. Move to the next field by pressing the [DOWN ARROW] key.
 - Enter the optional **Eng Cycles** (engine cycles) from the numeric keypad. Move to the next field by pressing the [DOWN ARROW] key.
 - When all fields are completed as desired, press [ENTER] to accept these settings and continue.

C. Data Acquisition

- When the INSTRUCTIONS screen below is displayed you may either start engines or if engines or already running, wait until the engine is at normal operating temperature, then press [ENTER] to continue. If the engine is APR equipped, it should be ARMED and ON prior to beginning data acquisition.

```
.....|| Tue 27Nov2001 16:42 4300Kb
Performance C1b

INSTRUCTIONS

Press ENTER when engine is at
normal operating temperature.

Press any key to continue.
```

2. The User Query banner screen will be displayed with the message “Do you want to Perform a Surge Bleed Valve Check Now?”. Use the [RIGHT ARROW] key to toggle the answer field to YES or NO, then press [ENTER] to accept your choice.

```
.....|| Tue 27Nov2001 16:48 4300Kb
User Query

Do you want to Perform a
Surge Bleed Valve Check Now?

NO

Use ← → to Select Yes or No
```

- 2.1 If you chose “NO” go to item 3 below. If you chose “YES” the Surge Valve Check banner screen will be displayed as shown below with the instructions to “Switch Engine Computer To Manual Mode”. When the engine computer is in Manual Mode, press [ENTER] to continue or press [DIAGNOSTIC] to skip the test.

```
.....|| Tue 27Nov2001 16:51 4300Kb
Surge Valve Check

Switch Engine Computer
To Manual Mode

Press ENTER to continue
Press DIAGNOSTIC to skip test
```

- 2.2 If you pressed [ENTER] to continue the test, the screen below will be displayed instructing you set power for the test. When power is set as required, press [ENTER] to continue the test or [DIAGNOSTIC] to quit.

```

-----|| Tue 27Nov2001 16:51 4300Kb
Surge Valve Check

Set Engine To Max N1 or ITT
Current N1 92.7%

Press ENTER when at power
Press DIAGNOSTIC to quit

```

- 2.3 If you pressed [ENTER] to continue the test, the screen below will be displayed showing averaged N1%, N2% and ITT in the Manual Mode. The running average time is shown at the top of the screen. When all three of the readings are reasonably stable, press [ENTER] to stop averaging or [DIAGNOSTIC] to abort the test.

SURGE BLEED VALVE CHK			
Averaging Time: 0:44			
	N1%	N2%	ITT°C
Manual	92.7	94.5	918.0
Press ENTER to stop averaging Press DIAGNOSTIC to abort test			

- 2.4 If you pressed [ENTER] to continue the test, the information screen below will be displayed instructing you to “Decelerate Engine To Idle And Switch Engine Computer To Normal Mode”. After the engine is at Idle and the computer is switched to Normal, press [ENTER] to continue the test or [DIAGNOSTIC] to quit the test.

```

-----|| Tue 27Nov2001 16:55 4300Kb
Surge Valve Check

Decelerate Engine
To Idle And Switch Engine
Computer To Normal Mode

Press ENTER to continue
Press DIAGNOSTIC to quit

```

- 2.5 If you pressed [ENTER] to continue the test, the information screen below will be displayed instructing you to “Set Engine To XX% N1” followed by the “Current N1%” for comparison. When the “Current N1%” matches the “Set Engine To N1%”, press [ENTER] to continue or [DIAGNOSTIC] to quit.

```

-----|| Tue 27Nov2001 16:55 4300Kb
          Surge Valve Check

          Set Engine To 92.7% N1
          Current N1 92.7%

Press ENTER when at power
Press DIAGNOSTIC to quit

```

- 2.6 If you pressed [ENTER] to continue the test, the test screen below will be displayed now showing Normal, Manual and the Delta readings of N1%, N2% and ITT. The Averaging Time is again shown in the upper right corner of the screen. When all readings are stable, press [ENTER] to stop the averaging or [DIAGNOSTIC] to abort the test. After pressing [ENTER], the averaging will stop and the two instructions at the bottom of the screen will change to indicate that you should “Record Displayed Data”, then press [ENTER] when finished and ready to continue with the calibration run.

SURGE BLEED VALVE CHK			
Averaging Time: 1:57			
	N1%	N2%	ITT°C
Normal	92.7	94.5	918.0
Manual	92.7	94.5	918.0
Delta	0.0	0.0	0.0
Record Displayed Data Press ENTER when finished			

SURGE BLEED VALVE CHK			
Averaging Time: 16:41			
	N1%	N2%	ITT°C
Normal	92.7	94.5	918.0
Manual	92.7	94.5	918.0
Delta	0.0	0.0	0.0
Record Displayed Data Press ENTER when finished			

3. The WARNING screen below will be displayed. The warning is to remind the operator that the N1 DEEC computer will be in a non-default state due to the analyzer and JEDA being connected during the performance calibration run. The computer will not cycle to a normal (default) configuration independently if power to the analyzer or the JEDA unit is lost. Therefore, the operator must cycle N1 DEEC power to return the computer to the default setting whenever power loss to either of the units is indicated or suspected for the duration of this procedure. Press any key to acknowledge this warning and continue.

```

-----|| Tue 27Nov2001 16:59 4300Kb
-----| Performance Clb
WARNING
N1DEEC will be in a non-default
state. If the analyzer loses
power or the test is incomplete,
cycle N1DEEC power.
Press any key to continue.

```

- The INSTRUCTIONS screen below will be displayed directing you to “Accelerate engine to takeoff power and press ENTER.”. The OAT is provided on this screen for use in calculating N1 for the Day. At this time, smoothly accelerate the engine to N1 for the day. When the engine is stable at this power setting, press [ENTER].

```

-----|| Tue 20Nov2001 11:31 4306Kb
-----| Set Engine Power
INSTRUCTIONS
Accelerate engine
to N1 for the Day
and press ENTER
OAT: 21.0 °C

```

- The INSTRUCTIONS screen shown below will be displayed indicating that EMS will now take control of the power adjustments and limit the upper range of PLA power settings. If conditions dictate, you may still take control of the engine manually and reduce engine power with the power lever. Press any key to acknowledge the instructions and continue.

```

-----||| Tue 27Nov2001 17:57 4283Kb
-----| Performance Clb
INSTRUCTIONS
EMS is beginning the test and
will adjust and limit the upper
range of PLA power settings.
Power can still be reduced.
Press any key to continue.

```

- After you press [ENTER] the Stabilization period will begin automatically. The screen below will indicate current conditions. Other than for emergencies or as directed by ground control, do not press any keys or make engine power adjustments until instructed to do so by the analyzer. Data acquisition is automated from this point on until all points have been acquired.

Mon 19Nov2001 12:15 4302Kb			
Stabilization			
P/Set:	1	Time:	0:04
Scans:	69	Stat:	InProgress
N1	92.69	N2	94.47
Percent		Percent	
ITT	918.00	FuelFlw	220.0
°C		Lbs/hr	
PrsAlt	751	OAT	21.50
Feet		°C	

7. When the Stabilization period is terminated automatically by EMS, the screen will change to indicate EMS is in the data acquisition mode and collecting data for the first point as indicated in the upper left corner of the screen "P/SET 1". Notice also in the banner that the "N2GOV" indication has appeared to indicate that the 45 second stabilization period has expired and the engine is now under N2 governing for data acquisition. As with the Stabilization period, EMS will advance the program automatically when acquisition is complete.

Mon 19Nov2001 12:16 4302Kb			
N2GOV Acquisition			
P/Set:	1	Acceptable:	1
Time:	0:08	Quest'able:	0
Scans:	134	Unreliable:	0
N1	92.69	N2	94.47
Percent		Percent	
ITT	918.00	FuelFlw	220.0
°C		Lbs/hr	
PrsAlt	751	OAT	21.50
Feet		°C	

8. If the [ENTER] key is pressed or the PLA is moved at any time during the stabilization or acquisition phase, the message below will be displayed on screen.

Mon 19Nov2001 16:00 4255Kb	
Wait Period	
Stopping Acquisition	
Please wait...	

It will remain in view momentarily then change to the screen below if the [ENTER] key was pressed. If you are simply pausing the acquisition and do not intend to abort the data acquisition, leave this screen in view until ready to continue, then press the [ENTER] key again while the "NO" answer is in view. The data acquisition will then continue. Use the [RIGHT ARROW] key to toggle the answer to "YES" if you *do* intend to abort the acquisition. With the "YES" answer in view, the screen will proceed directly to step 12 below.

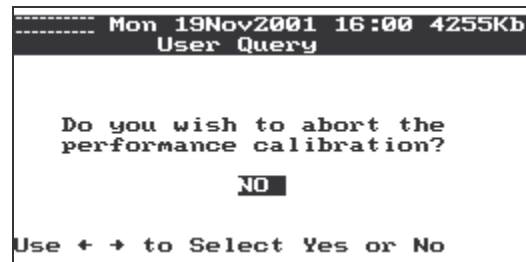

If the pause was initiated by movement of the PLA or high electrical noise produced by the PLA potentiometer, the screen below will be displayed asking if you moved the PLA. If you select the “YES” answer, the screen above will be displayed. If you then answer “YES” in the screen above, the analyzer will proceed directly to step 12 below. If you answered “NO” in the screen above, EMS will automatically adjust the PLA potentiometer voltage range to compensate for the high noise level then continue data acquisition.

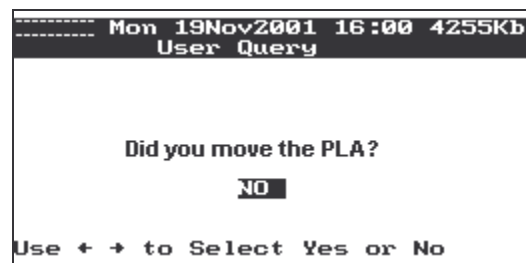

9. As the Acquisition period for each point is completed, EMS will automatically display the Data Quality screen shown below. If the data is not acceptable, this screen will display that message. In this case, or if for any other reason you should wish to retake this point, press the [DIAGNOSTIC] key, on the 1700, or the [ANALYZER] key on the 1725. If the data is acceptable and you are ready to proceed to the next point power setting, press [ENTER] to proceed.

```

----- Mon 19Nov2001 12:17 4302Kb
----- NZGOV P/W Set 1 Pt 1

Data Quality: Acceptable

```

N1(%)	92.69	N1StdDv	0.00
N2(%)	94.47	PLA	122.00
ITT	918	PT2	13.78
OAT	21.50	TI2	62.26
PrsAlt	751	FuelFlw	220.0

```

-----
<->, ENTER=accept DIAG=retake

```

10. The Cockpit Readings screen will be displayed where you may enter N1, N2, and ITT readings from the cockpit instruments. Use the [DOWN ARROW] key to move between fields and enter the readings using the numeric keypad. The line at the bottom of the screen will indicate the valid range for each of the readings. When all fields are complete for this point, press [ENTER] to continue.

NOTE

When running EMS with an N1 DEEC equipped engine, **DO NOT ADJUST POWER** for the next acquisition point. EMS will automatically make all power reductions necessary for the first five power sets of the calibration run.

```

----- Mon 19Nov2001 14:14 4286Kb
----- N2GOV Cockpit Readings

Cockpit N1 (% max) : 92.600
Cockpit N2 (% max) : 94.700
Cockpit ITT (Deg C): 919.00

Valid Range is 30-110

```

11. A brief information screen will be displayed indicating that EMS is “Adjusting N1 governor... Please wait...” in preparation for the next stabilization and acquisition period.

```

----- Tue 20Nov2001 11:33 4306Kb
----- Wait Period

Adjusting N1 governor...

Please wait...

```

12. When the information screen extinguishes, the process will repeat from item 5, through item 11 above for each of the first five points. When data is acquired for all five points, or the procedure is aborted, the screen below will be displayed instructing you to reduce power. The large “N2 : XX.X%” indication at the bottom of the screen is the current N2%. Slowly retard the PLA until this indication matches the target indication in the line just above it. When the actual power matches the target setting, press [ENTER] to continue.

```

----- Wed 28Nov2001 10:08 4277Kb
----- Wait Period

INSTRUCTIONS

Reduce PLA slowly until the
engine slows below N2=92.6%

N2: 94.5%

```

13. The INSTRUCTIONS screen below will be displayed to indicate that control of the engine computer is being returned to the user. Acknowledge and continue by pressing any key.

```

----- Wed 28Nov2001 13:53 4250Kb
----- Performance Clb

INSTRUCTIONS

Full control is being
returned to the user.

Press any key to continue.

```

14. The screen will display the User Query below. If you intend to collect additional points, you may acquire up to 7 additional power sets by answering “YES” to the query. Use the [RIGHT ARROW] key to toggle the answer between YES and NO then press [ENTER] to accept your choice and continue. If you choose "NO", the screen will proceed to item 16 below. If you selected “YES” the screen will proceed to item 13 below.

```

----- Mon 19Nov2001 15:10 4264Kb
----- User Query

Would you like to acquire
another power set?

  NO

Use ← → to Select Yes or No

```

15. If you selected “YES” from the User Query screen above, the screen below will be displayed directing you to “Set desired engine speed and press [ENTER]. The screen will then repeat the sequence described in items 5 through 11 above, then return to the user query screen above in item 11. You may acquire up to seven additional points, for a total of twelve, in this manner. After the 12th point is acquired or if you select “NO” in step 12 above, proceed to step 16 below.

```

----- Wed 28Nov2001 13:57 4250Kb
----- Performance Clb

INSTRUCTIONS

Set desired engine speed and
press ENTER.

Press any key to continue.

```

16. If you selected “NO” in step 12 above, and a Surge bleed valve check was not conducted previously, the screen below will be displayed allowing you to conduct a Surge Bleed Valve Check prior to engine shutdown. Use the [RIGHT ARROW] key to toggle the answer field between YES and NO. If you selected “NO” proceed to step 17 below. If you selected “YES”, go to item 2 of this section.

```

----- Wed 28Nov2001 14:01 4250Kb
----- User Query

Do you want to Perform a
Surge Bleed Valve Check Now?

NO

Use + - to Select Yes or No

```

17. After the twelfth point is acquired, or when the operator chooses the “NO” answer in the User Query screen above in item 12., the INSTRUCTIONS screen below will be displayed. Move the PLA to the idle position and cycle the N1 DEEC computer power switch. Press any key to return to the main menu.

```

----- Wed 28Nov2001 14:07 4250Kb
----- Performance Clb

INSTRUCTIONS

Please cycle power on
the N1DEEC.

Press any key to continue.

```

NOTE

At this point you may alternately choose to complete the JEDA Overspeed Test which will shutdown the engine. If you wish to complete this test, do not shutdown the engine but proceed to the JEDA OVERSPEED TEST section of this document.

REVIEW

1. The review function of the EMS procedure allows you to view data collected and stored in the analyzers memory. To access the data, select “2—Review” from the main menu and press [ENTER]

```

----- Tue 20Nov2001 12:02 4300Kb
----- Performance DEMO

Page 1 of 2
1--Start
2--Review
3--Transfer To PC
4--Delete
5--Print
6--Communications Test
[More]
Select Option

```

- The analyzer will display the last collected, or last viewed data of a performance calibration run. In the first line of the screen, you will see a number (#29 in the example screen below) indicating the sequential number of this run in the available list. Immediately to the right of the number is the day/date/time stamp indicating when the data was acquired. The remainder of the information is relative to the engine as entered by the operator when the data was collected. Use the [UP ARROW] and [DOWN ARROW] keys to scroll through the list of available data sets. Press [ENTER] to view all data for the selected engine (see item 3 below). Press [DIAOGNISTICS], for 1700 analyzers, or [ANALYZER], for 1725 analyzers, to quit the review and return to the main menu.

```

----- Tue 20Nov2001 12:03 4300Kb
----- Perf Calib List

#29: 20Nov2001 11:30:58
Engine Model: TFE731-2-2B
Engine S/N: 111666
Status: Finished

Use ▲ ▼ keys to select test
Press ENTER to accept
Press DIAG/ANALYZER to quit

```

- If you select a data set to view, the screen below will be displayed with information pertaining to the selected data set. Optional information such as the Customer Name and Aircraft Serial number will be blank if not entered by the equipment operator at the time the data was collected. You may not edit or delete the information on this screen. For each of the next three screens, if you wish to view the next page for this data set, press the [RIGHT ARROW] key until the “Continue:” answer field reads “Yes” then press [ENTER]. If you do not wish to view the next page, select “No” in the answer field and press [ENTER] to return to the main menu.

```

----- Tue 20Nov2001 12:04 4300Kb
----- Perf Calib Setup

Created : 20Nov2001 11:30:58
Customer:
Aircraft S/N :
Aircraft Model: Lear 35/36
Engine S/N : 111666
Engine Model : TFE731-2-2B
Continue : Yes

Enter Selection

```

```

----- Tue 20Nov2001 12:04 4300Kb
----- Perf Calib Setup

Engine Hrs : 1
Engine Cycles : 1
Temp Display Units: °C
Fuel LHV(BTU/lbm) : 14000.
Nozzle : Lear Coannular
Reason : Other
Continue: Yes

Enter Selection

```

```

----- Tue 20Nov2001 12:06 4300Kb
----- Perf Calib Setup

N1 Compensation: -2   50 RPM
Fuel Spec Grav : 0.6800
Bypass T5      : No

Continue:  Yes
Enter Selection

```

4. If you have chosen to view the collected data, the screen below will be displayed indicating the Power Set number and Point number for that set in the banner at the top of the screen. The redundant cockpit readings are listed directly below the banner, followed by the data collected by EMS. As indicated at the bottom of this screen, use the [UP ARROW] or [DOWN ARROW] keys to change the Power Set number and the [RIGHT ARROW] and [LEFT ARROW] keys to change the Point number. When you are finished viewing the data, press [ENTER] to return to the main menu. To print the data, see the **PRINT** section of this document.

```

----- Tue 20Nov2001 12:06 4300Kb
----- P/W Set 1 Pt 1
Cockpit Readings:
N1=30.00 N2=30.00 ITT=100.00
Data Quality: Acceptable

|        |       |         |        |
|--------|-------|---------|--------|
| N1(%)  | 92.69 | N1StdDv | 0.00   |
| N2(%)  | 94.47 | PLA     | 122.00 |
| ITT    | 918   | PT2     | 13.78  |
| OAT    | 21.50 | TT2     | 62.26  |
| PrsAlt | 751   | FuelFlw | 220.0  |

▲ ▼ = P/W Set, ◀ ▶ = DataPt

```

TRANSFER TO PC

- After a performance calibration run has been acquired and stored in the analyzer, it should be transferred to a PC where the data can be reduced by MEDRA. To accomplish this, you must have a current version of JEDA Comm for Windows® and a current version of MEDRA®. Connect the analyzer to your PC per the instructions in the analyzer users manual. Start the JEDA Comm software and insure optional settings are correct. On the EMS menu, select “3—Transfer To PC” and press [ENTER].

```

----- Tue 20Nov2001 12:10 4296Kb
----- Performance DEMO

Page 1 of 2
1--Start
2--Review
3--Transfer To PC
4--Delete
5--Print
6--Communications Test
[More]
Select Option

```

- The analyzer will display the last collected, or last viewed data of a performance calibration run. In the first line of the screen, you will see a number (#29 in the example screen below) indicating the sequential number of this run in the available list. Immediately to the right of the number is the day/date/time stamp indicating when the data was acquired. The remainder of the information is relative to the engine as entered by the operator when the data was collected. Use the [UP ARROW] and [DOWN ARROW] keys to scroll through the list of available data sets. Press [ENTER] to transfer the selected data to the PC (see item 3 below). Press [DIAOGNISTICS], for 1700 analyzers, or [ANALYZER], for 1725 analyzers, to quit the transfer procedure and return to the main menu.

```
----- Tue 20Nov2001 12:11 4296Kb
----- Perf Calib List

#29: 20Nov2001 11:30:58
Engine Model: TFE731-Z-2B
Engine S/N: 111666
Status: Finished

Use ▲ ▼ keys to select test
Press ENTER to accept
Press DIAG/ANALYZER to quit
```

- When you begin the transfer, the screen below will be displayed to indicate the analyzer is attempting to establish communications with the PC. Do not interrupt this process unless you wish to stop it. Press the [DIAGNOSTICS] key on the 1700, or the [ANALYZER] key on the 1725 to abort the transfer from this point and return to the main menu.

```
----- Tue 20Nov2001 12:11 4296Kb
----- Wait Period

Waiting for handshake...
Press DIAG/ANALZER to quit.

Please wait...
```

- If not interrupted and all communications parameters are correct, the analyzer screen will display the message below to indicate the transfer is in progress.

```
----- Tue 20Nov2001 12:12 4296Kb
----- Wait Period

Transferring Data To PC...

Please wait...
```

5. If communications cannot be established, the screen will indicate an error as shown in the example below. If this occurs, check the cable, connections, and communications settings in both the analyzer and the JEDA Comm software. If no errors are encountered, the transfer will be completed and the screen will return to the main menu of EMS so that you may transfer additional data. The sequence is then repeated for each data set you wish to transfer.

```
----- Tue 20Nov2001 12:12 4296Kb
----- Wait Period

Transferring Data To PC...

Please wait...
Data Transfer Error
```

DELETE

1. After a performance calibration run has been acquired and stored in the analyzer, it should be transferred to a PC where the data can be reduced by MEDRA. After the data is transferred to MEDRA, you should delete the data set from the analyzer to free available memory. To accomplish this, select “4--Delete” from the EMS main menu and press [ENTER].

```
----- Tue 20Nov2001 12:13 4296Kb
----- Performance DEMO

Page 1 of 2
1--Start
2--Review
3--Transfer To PC
4--Delete
5--Print
6--Communications Test
[More]
Select Option
```

2. The analyzer will display the last collected, or last viewed data of a performance calibration run. In the first line of the screen, you will see a number (#1 in the example screen below) indicating the sequential number of this run in the available list. Immediately to the right of the number is the day/date/time stamp indicating when the data was acquired. The remainder of the information is relative to the engine as entered by the operator when the data was collected. Use the [UP ARROW] and [DOWN ARROW] keys to scroll through the list of available data sets. Press [ENTER] to select this data set for deletion from the analyzer (see item 3 below). Press [DIAOGNISTICS], for 1700 analyzers, or [ANALYZER], for 1725 analyzers, to quit the delete process and return to the main menu.

```

----- Tue 20Nov2001 12:14 4296Kb
----- Perf Calib List

#1: 01Nov2001 19:31:44
Engine Model: TFE731-4-1T
Engine S/N:
Status: Finished

Use ▲ ▼ keys to select test
Press ENTER to accept
Press DIAG/ANALYZER to quit

```

- After selecting the file to be deleted, the verification screen shown below will be displayed. This allows the operator to verify that he does wish to delete this data set and prevents accidental deletions. The answer field defaults to “NO”. If you did not intend to delete the file, simply press the [ENTER] key with the “NO” answer in view and the screen will return to the main menu. If you do intend to delete the selected data set, use the [RIGHT ARROW] key to toggle the answer field to “YES”, then press [ENTER]. The data will be permanently removed from the analyzers memory and cannot be recovered.

```

----- Tue 20Nov2001 12:14 4296Kb
----- User Query

Delete this Data Set!
Are you sure?

NO

Use ← → to Select Yes or No

```

PRINT

- You may print the collected Performance Calibration data directly from the analyzer to a printer if desired. (See the analyzer users manual on printing). After a performance calibration run has been acquired and stored in the analyzer, it should be transferred to a PC where the data can be reduced by MEDRA. As an option, or additionally, if you wish to print the collected data, you may do so using the print function of the main menu. To accomplish this, select “5--Print” from the EMS main menu and press [ENTER].

```

----- Tue 20Nov2001 12:16 4293Kb
----- Performance DEMO

Page 1 of 2

1--Start
2--Review
3--Transfer To PC
4--Delete
5--Print
6--Communications Test
   [More]
Select Option

```

- The analyzer will display the last collected, or last viewed data of a performance calibration run. In the first line of the screen, you will see a number (#29 in the example screen below) indicating the sequential number of this run in the available list. Immediately to the right of the number is the day/date/time stamp indicating when the data was acquired. The remainder of the information is relative to the engine as entered by the operator when the data was collected. Use the [UP ARROW] and [DOWN ARROW] keys to scroll through the list of available data sets. Press [ENTER] to select this data set for printing directly from the analyzer. The data set will be sent to your printer and the screen will return to the EMS main menu where you may choose to print additional data sets. Press [DIAOGNISTICS], for 1700 analyzers, or [ANALYZER] on the 1725 to quit the print process and return to the EMS main menu.

```

----- Tue 20Nov2001 12:16 4293Kb
----- Perf Calib List

#29: 20Nov2001 11:30:58
Engine Model: TFE731-2-2B
Engine S/N: 111666
Status: Finished

Use ▲ ▼ keys to select test
Press ENTER to accept
Press DIAG/ANALYZER to quit

```

COMMUNICATIONS TEST

- A communications Test selection is provided on the EMS main menu to allow you to verify that the analyzer is communicating successfully with the N1 DEEC, the JEDA unit, and the associated temperature and pressure sensors. To conduct a communications test, select “6—Communications Test” from the EMS main menu and press [ENTER].

```

----- Tue 20Nov2001 12:18 4290Kb
----- Performance DEMO

Page 1 of 2

1--Start
2--Review
3--Transfer To PC
4--Delete
5--Print
6--Communications Test
[More]
Select Option

```

- The screen will display the Comm Test banner at the top of the screen and the first communications check in the main portion of the screen. The Name field indicates the

variable being tested. The Source indicates where the signal is being transmitted from and the Value indicates the actual value of the signal being transmitted. A 0.0 in the Value field indicates that a signal is not being transmitted. Use the [ARROW] keys to scroll through the variables. Press [NOTEPAD], on the 1700 analyzer, [BACKUP], on the 1725 analyzer, or [ENTER] on either analyzer to exit the Communications Test.

```

----- Tue 20Nov2001 12:19 4290Kb
----- CommTest
Name      = N1
Source    = N1DEEC
Value     = 19900.00

Use ENTER/BACKUP to exit.
Use cursors for more variables

```

JEDA OVERSPEED TEST

1. The JEDA Overspeed Test is conducted with the engine at idle. From the main menu, select “7—JEDA Overspeed Test” and press [ENTER].

```

----- Mon 19Nov2001 17:03 4237Kb
----- Performance Calib
-----
----- Page 2 of 2
----- 7--JEDA Overspeed Test
----- 8--JEDA Overtemp Check
----- 9--Exit
-----
----- [More]
----- Select Option

```

2. The Test banner screen below will be displayed. Take note that this test will shut down the engine. If other checks requiring the engine to be running are pending, you may wish to delay this test until all other checks are complete. As indicated in this screen, YOU MUST complete the test cycle. This means you must complete all steps through item 5, below, of this procedure. When you are ready to begin the OVERSPEED SOLENOID TEST, press [ENTER]. If you wish to abort this test and return to the Performance Calibration main menu, press any other key.

```

----- Mon 19Nov2001 17:04 4237Kb
----- Test
-----
----- OVERSPEED SOLENOID TEST
-----
----- This test will shut down the
----- engine. YOU MUST complete
----- the test cycle.
-----
----- Press ENTER to start the test.
----- Press Other key to abort test.

```

3. The Wait Period banner screen below will be displayed indicating that the Overspeed Solenoid Test is in progress. Do not press any keys or make power adjustments until the analyzer instructs you to do so.

```
----- Mon 19Nov2001 17:04 4237Kb
----- Wait Period

      Test in progress...
      Waiting for engine shutdown.

      Please wait...
```

4. When the overspeed check initiates the engine shutdown, the screen below will be displayed to indicate that the shutdown is in progress . At this time you should move the power lever to the cutoff position. DO NOT PRESS ANY KEYS or make engine adjustments until the screen indicates the test is complete. This occurs when the engine is sufficiently slowed to an acceptable RPM as detected by the JEDA. When the analyzer screen indicates the test is complete, you may continue normal operation as required.

WARNING

YOU MUST ALLOW THIS TEST TO COMPLETE once started. Failure to do so may result in a hot starts on subsequent engine operation.

```
----- Mon 19Nov2001 17:05 4237Kb
----- Wait Period

      Engine started shutdown
      Move power lever to cutoff.

      Please wait...
```

JEDA OVERTEMP CHECK

1. The JEDA unit has the capability to induce a simulated overtemp condition for engine testing. To conduct an overtemp check, from the main menu select “8—JEDA Overtemp Check” and press [ENTER].

```

----- Mon 19Nov2001 17:09 4237Kb
Performance DEMO

          Page 2 of 2
7--JEDA Overspeed Test
8--JEDA Overtemp Check
9--Exit

                               [More]
Select Option

```

- The analyzer screen will display an INSTRUCTIONS page “Stabilize engine at N1 for the Day. Press ENTER to continue.” Calculate N1 for the day then accelerate the engine to that speed. Allow the engine to stabilize then press [ENTER] to continue.

```

----- Wed 28Nov2001 15:36 4227Kb
JEDA Status

          INSTRUCTIONS

Stabilize engine at N1 for
the Day.
Press ENTER to continue.

Press any key to continue.

```

- The screen will display two lines, “N2 Percent :” followed by the current N1 %, and “Simulated ITT :” followed by the temperature. As indicated at the bottom of the screen, use the [UP ARROW] to increase and the [DOWN ARROW] key to decrease the simulated temperature. As the temperature limit is reached, the fuel will be reduced and the N2 Percent indication on the first line will begin to decrease. This indicates the test is successful. Press [ENTER] to abort the test and return to the main menu.

```

----- Mon 19Nov2001 17:10 4237Kb
JEDA Status

N2 Percent      : 97.8
Simulated ITT  : 900.0

Press ▲ ▼ to change temp.
Press ENTER to abort.

```

EXIT

Selecting the “9—Exit” item from the main menu will exit the TFE731 EMS procedure and return to the Operation Options menu of the analyzer.

