



Application Note

General Electric CF6-50

S.B. 72-1313 Vibration Survey

Part Number: 11-200-0298

AppNote Number: E-GE-CF6-50-4040-VS (Rev. 1, Mar 4, 2011)

This Application Note is provided for information only and does not supersede the requirements or guidelines set forth in the applicable engine or airframe maintenance manual. Technology for Energy Corporation assumes no obligation or liability, either expressed or implied, to the Purchaser arising out of the use of this procedure.

Copyright © 2006, TEC Aviation Division. All rights reserved. This document is to be printed and reproduced for personal use only.



Application Note

Application Note Number	E-GE-CF6-50-4040-VS
Revision	
Function	S.B. 72-1313 Vibration Survey
Airframe	Various
Engine	General Electric CF6-50
E-Setup Number	e-ge-cf6-50-4040-vs
ACES Systems Analyzer	
Firmware Version	3.05 or Higher
Procedure	3.05i or Higher

Introduction

This Application Note covers the required equipment, equipment installation, analyzer setup, data acquisition and solution process for using the ACES Systems Model 4040 to perform an Engine Vibration Survey on the engine listed above. General instructions for the use of the Model 4040 can be found in the Model 4040 User Manual. All procedures for Engine Vibration Survey and all adjustments should be made in accordance with the Aircraft Maintenance Manual or Service Bulletin as appropriate.

A. Required Equipment

The following ACES Systems equipment is required:

Item	Quantity	Description	Part Number
1.	1EA	ANALYZER, VIPER 4040	10-100-4040
2.	1EA	CABLE, TACH	10-320-0126
3.	1EA	CABLE, N2	10-320-0343
4.	1EA	CABLE, VIBE	10-320-0159
5.	1EA	CONVERTER, CHARGE, MODEL 539	10-100-0539
6.	1EA	CABLE, HI TEMP	10-320-0008
7.	1EA	MOUNT, SENSOR, CF6 LPT	22-430-0171
8.	1EA	SENSOR, VIBE, ACCEL, 6233C-50	69-100-0069



*This listing shows the latest design parts. It is acceptable to perform this task using previous designs with the appropriate accessories. For compatibility issues, contact ACES Systems.

Items 10 and 11 in Optional equipment below is required only if you wish to conduct Fan Trim Balance on the engine. Items 9 and 12 may be necessary to extend the tachometer and vibration cable lengths from the engine to the location of the analyzer depending on the airframe and engine installation.

Optional Equipment

Item	Quantity	Description	Part Number
9.	1EA	CABLE, GENERIC TACH	10-320-0126
10.	1EA	TACHOMETER, OPTICAL LASETACH	10-100-1300
11.	1EA	MOUNT, LASETACH SWIVEL	10-100-0369
12.	1EA	CABLE, GENERIC VIBE	10-320-0127

Miscellaneous Equipment

Tape or tie wraps and aluminum speed tape to secure cables to airframe.

B. Equipment Installation

For all engines, follow the AMM or CF6-50 EM procedures to perform an N2 vibration check (vibration survey) except as follows:

1. Install the vibration sensor mount, item 7, on the turbine mid frame (TMF), on the left side of the engine adjacent to the EVM sensor. The triangular shape should have one point directed aft for proper positioning of the sensor (see Figure 2.).
2. Install the Accelerometer (vibration sensor) item 8, on the vibration sensor mount, item 7, using three 8/32 screws. Torque screws to approximately 12 inch pounds.
3. Connect the smaller end of the Hi Temp cable, item 6, to the Accelerometer, item 8. Route the high temp cable up the engine, securing along its route with ties or speed tape, and out the vent near the top of the cowling door.
4. Connect the opposite end of the Hi Temp cable, item 6, to the two pin input side of the 539 charge converter, item 5. Secure the high temp cable to the pylon with speed take for the full length that will be in the bypass air stream (see Figure 5.) Secure the charge converter to the upper surface of the wing to prevent movement to the greatest extent possible.
5. Connect the Vibration Cable, item 4, to the four pin output side of the 539 charge converter, item 5. Route the cable along the wing and fuselage toward the cockpit, securing every three feet with speed tape to prevent movement or possible injection into the engine. If necessary to extend the length of the cable, connect additional 50 ft. generic vibrate cables, item 12, as necessary in a daisy chain pattern to reach the analyzer. For example, the DC-10 is

approximately 170 feet long. It may require four cables of 50 feet each (one item 4 plus three items 12) to connect the vibration sensor on engine #2 to the analyzer located in the cockpit. If the aircraft has a cargo door with an access panel to the locking controls, the cable may be routed through that access panel to the interior of the aircraft. Other options include routing to the cockpit and through the pilots side window.

6. Connect the vibration cable, item 4, or Generic Vibe cable, item 12, to CHAN A input of the 4040 analyzer, item 1.
7. Disconnect the cable from the engine N2 tach generator. Attach the cable to the female matching connector of the N2 Cable, item 3. Attach the matching connector of the cable to the N2 tach generator.
8. Connect the remaining three pin connect of the N2 cable, item 3, to the generic tach cable, item 2. Route the cable away from hot structures and/or high voltage components and out through the cowl doors toward the location where the analyzer will be operated. Secure the cable to the engine cowling and airframe skin using aluminum speed tape to prevent movement or possible ingestion into the engine. If necessary to extend the length of the cable, connect additional 50 ft. generic tach cables, item 9, as necessary in a daisy chain to reach the analyzer. . For example, the DC-10 is approximately 170 feet long. It may require four cables of 50 feet each (four items 2) to connect the N2 breakout cable on engine #2 to the analyzer located in the cockpit. If the aircraft has a cargo door with an access panel to the locking controls, the cable may be routed through that access panel to the interior of the aircraft. Other options include routing to the cockpit and through the pilots side window

Equipment Installation Diagram

CF6- 50 Equipment Installation

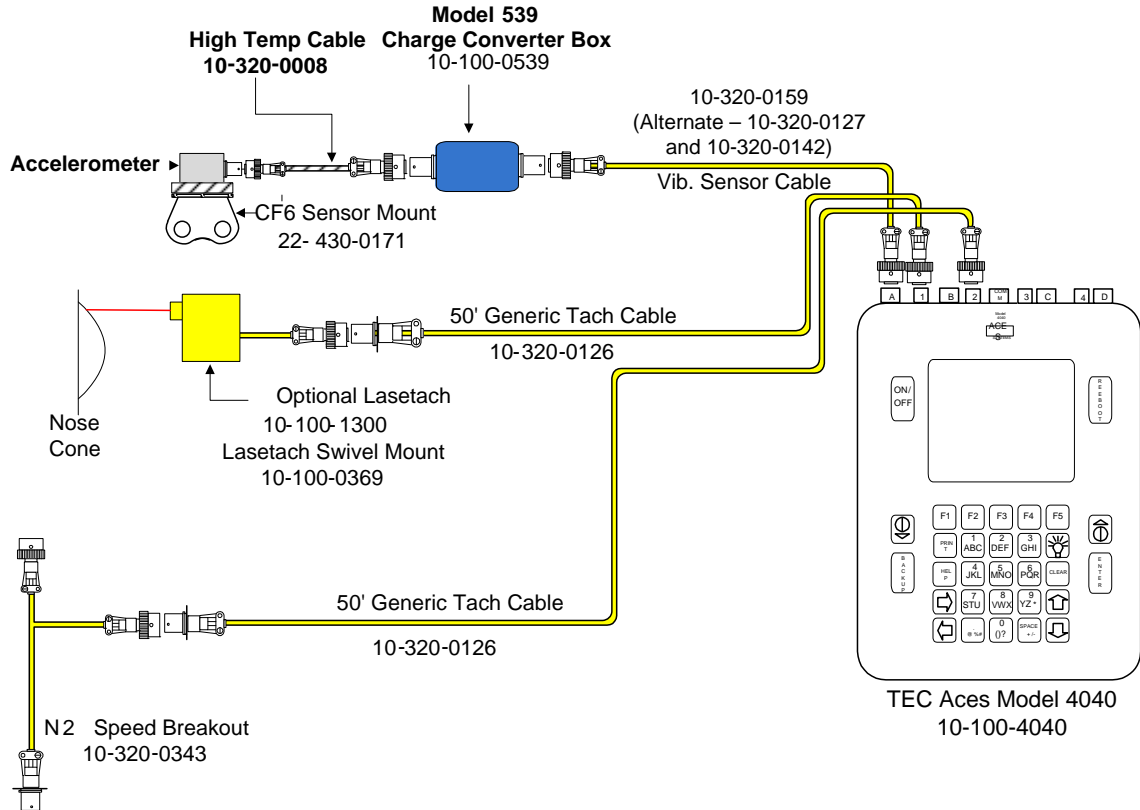

Illustration by J. Justice, October 27, 2010

Figure 1. Installation Diagram

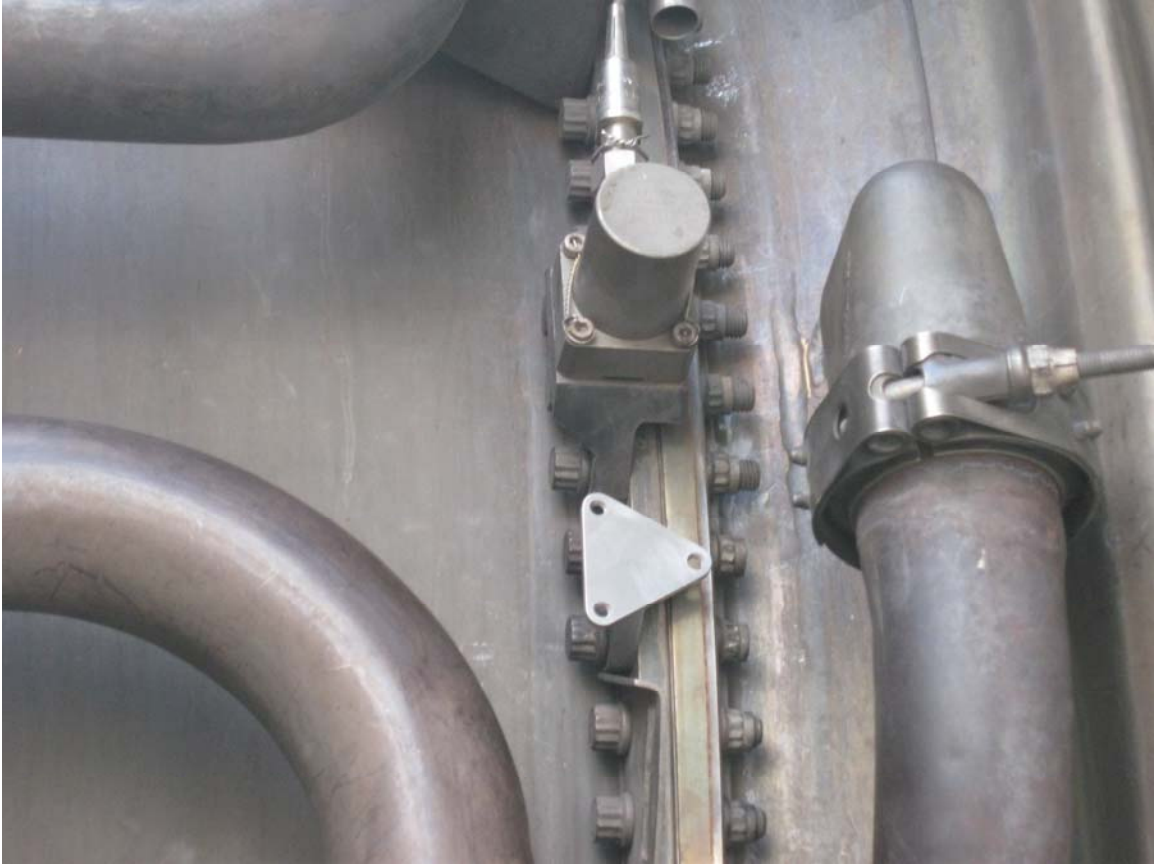

Figure 2. Sensor mount installed adjacent to the EVM sensor.

Figure 2.



Figure 3. Sensor installed on the mount with high temperature cable attached and routed toward top of engine.





Figure 4. High Temp cable routed from the sensor (lower left in the photo), up and out the vent near the pylon.

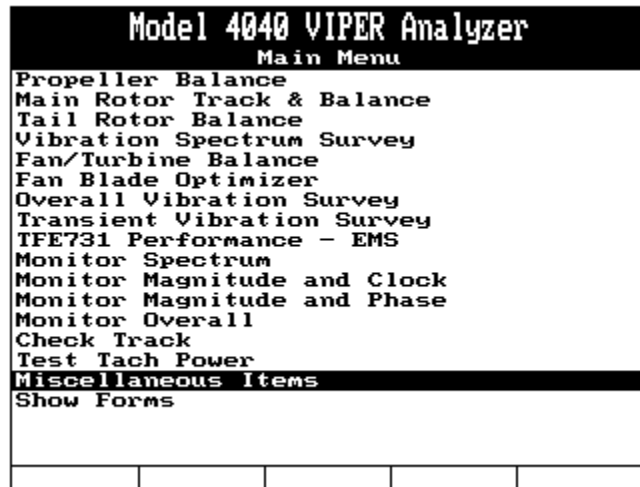

Figure 5. High Temp cable routed from the vent, up the pylon and to the top of the wing. Speed tape must be used in the bypass air stream to insure security of the cable.



C. Analyzer Set Up

1. Turn the analyzer ON. At the main menu, select MISCELLANEOUS ITEM and press ENTER.



2. At the MISCELLANEOUS ITEMS menu, select SETUP SENSORS and press ENTER.

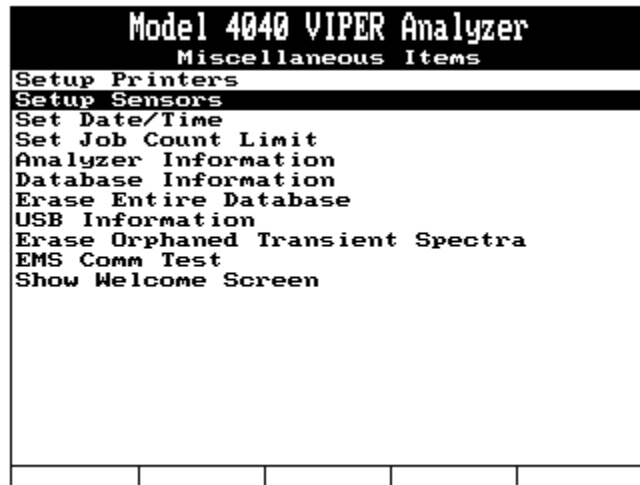

3. At the MANAGE SENSORS menu, select NEW and press ENTER.

Model 4040 VIPER Analyzer				
Sensor Setup				
Name:	PCB 357C72/ ACES 539			
Amplitude Units:	IPS			
Probe Sensitivity:	50.000			
Reverse Polarity:	No			
Input Type:	Single Ended			

5. At the MAIN MENU, select VIBRATION SPECTRUM SURVEY and press ENTER.

Model 4040 VIPER Analyzer				
Main Menu				
Propeller Balance				
Main Rotor Track & Balance				
Tail Rotor Balance				
Vibration Spectrum Survey				
Fan/Turbine Balance				
Fan Blade Optimizer				
Overall Vibration Survey				
Transient Vibration Survey				
TFE731 Performance - EMS				
Monitor Spectrum				
Monitor Magnitude and Clock				
Monitor Magnitude and Phase				
Monitor Overall				
Check Track				
Test Tach Power				
Miscellaneous Items				
Show Forms				

6. At the VIBRATION SPECTRUM SURVEY JOBS menu, select START JOB and press ENTER.

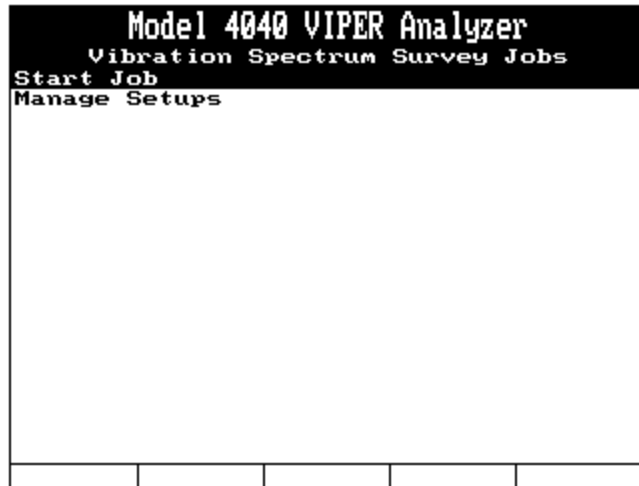

7. At the SETUP LIST menu, if the CF6-50 S.B.72-1313 setup is displayed, select it then press ENTER and proceed to section D. Data Acquisition below. Otherwise, if the setup is not displayed, press the [F1] "New" key and go to step 8. below.

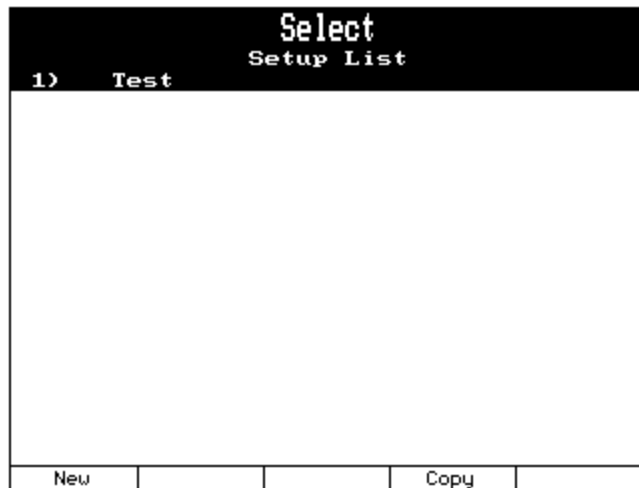

8. The SPECTRA SETUP screen will be displayed as shown in the example below.

Model 4040 VIPER Analyzer
Spectra Setup

Name:

(RPM): 0.00 to 10000.00

Resolution: 400 lines

Average Type: Expon. Blocks: 4

Channel	Units	Mod	MaxValue
A:	<input type="text"/> None		
B:	<input type="text"/> None		
C:	<input type="text"/> None		
D:	<input type="text"/> None		

Channel	Sensor	Desc
A:		
B:		
C:		
D:		

Edit Conds | Speeds | Limits | |

9. Use the screens and instructions below in steps 9 through 16 to complete the setup. For the first screen, complete the screen with the information shown in each block below. When all fields are complete as shown, press the [F1] "Edit Conds" key and go to step 10.

Model 4040 VIPER Analyzer
Spectra Setup

Name: CF6-50 SB 72-1313

(RPM): 6000.00 to 9000.00

Resolution: 400 lines

Average Type: Peak Blocks: 4

Channel	Units	Mod	MaxValue
A:	<input type="text"/> mils	<input type="text"/> Pk-Pk	<input type="text"/> 10.0
B:	<input type="text"/> None		
C:	<input type="text"/> None		
D:	<input type="text"/> None		

Channel	Sensor	Desc
A:	<input type="text"/> 6233C-50 with 539	<input type="text"/> LPT
B:		
C:		
D:		

Edit Conds | Speeds | Limits | |

10. In the CONDITIONS screen, complete the four conditions per the example shown below. When all fields are complete, press ENTER to accept and return to the SPECTRA SETUP screen and go to step 11. below.

Model 4040 VIPER Analyzer
Conditions

Condition	
1)	ACCEL #1
2)	DECEL #1
3)	ACCEL #2
4)	DECEL #2
5)	
6)	
7)	
8)	
9)	
10)	
11)	
12)	
13)	
14)	
15)	

11. At the SPECTRA SETUP screen, press the [F2] "Speeds" key and go to step 12. below.

Model 4040 VIPER Analyzer
Spectra Setup

Name: CF6-50 SB 72-1313
 (RPM): 6000.00 to 9000.00
 Resolution: 400 lines
 Average Type: Peak Blocks: 4

Channel	Units	Mod	MaxValue
A:	mils	Pk-Pk	10.0
B:	None		
C:	None		
D:	None		

Channel	Sensor	Desc
A:	6233C-50 with 539	LPT
B:		
C:		
D:		

Edit Conds | Speeds | Limits

12. Use the example screen below and complete the SPEED INPUTS SETUP screen as shown. When all fields are complete, press ENTER to return to the SPECTRA SETUP screen and go to step 13. below.

Model 4040 VIPER Analyzer				
Speed Inputs Setup				
	Measure	DESC	OFF/100%	Factor
1)	Pulse S-L	N2	0.00000	54.82287
2)	None		0.00000	1.00000
3)	None		0.00000	1.00000
4)	None		0.00000	1.00000

13. At the SPECTRA SETUP screen, press the [F3] "Limits" key. The definition for the "F" keys will change. Go to step 14. below.

Model 4040 VIPER Analyzer			
Spectra Setup			
Name: CF6-50 SB 72-1313			
RPM: 6000.00 to 9000.00			
Resolution: 400 lines			
Average Type: Peak Blocks: 4			
Channel	Units	Mod	MaxValue
A:	mils	Pk-Pk	10.0
B:	None		
C:	None		
D:	None		
Channel	Sensor	Desc	
A:	6233C-50 with 539	OPT	
B:			
C:			
D:			
Edit Conds	Speeds	Limits	

14. Press the [F1] "A-Limits" key and go to step 15. below.

Model 4040 VIPER Analyzer				
Spectra Setup				
Name: CF6-50 SB 72-1313				
RPM: 6000.00 to 9000.00				
Resolution: 400 lines				
Average Type: Peak Blocks: 4				
Channel	Units	Mod	MaxValue	
A:	mils	Pk-Pk	10.0	
B:	None			
C:	None			
D:	None			
Channel	Sensor		Desc	
A:	6233C-50 with 539		LPT	
B:				
C:				
D:				
A-Limits	B-Limits	C-Limits	D-Limits	Back

15. At the EDIT LIMITS FOR CHANNEL A: LPT screen shown below, use the screen as an example and complete each field as shown. When all fields are complete, press ENTER to accept and go to step 16. below.

Model 4040 VIPER Analyzer				
Edit Limits for Channel A: LPT				
	F-low	F-high	Unit	Limit
1)	6000.00	8250.00	xRPM	5.00
2)	0.00	0.00	xCS1	0.00
3)	0.00	0.00	xCS1	0.00
4)	0.00	0.00	xCS1	0.00
5)	0.00	0.00	xCS1	0.00
6)	0.00	0.00	xCS1	0.00
7)	0.00	0.00	xCS1	0.00
8)	0.00	0.00	xCS1	0.00
9)	0.00	0.00	xCS1	0.00
10)	0.00	0.00	xCS1	0.00
11)	0.00	0.00	xCS1	0.00
12)	0.00	0.00	xCS1	0.00
13)	0.00	0.00	xCS1	0.00
14)	0.00	0.00	xCS1	0.00
CopyToAll		CopyToB	CopyToC	CopyToD

16. At the SPECTRA SETUP screen, press ENTER to accept all settings and save the setup to the analyzer memory. At this point you may continue with the job or alternately turn the analyzer off.

Model 4040 VIPER Analyzer			
Spectra Setup			
Name: CF6-50 SB 72-1313			
RPM: 6000.00 to 9000.00			
Resolution: 400 lines			
Average Type: Peak Blocks: 4			
Channel	Units	Mod	MaxValue
A:	mils	Pk-Pk	10.0
B:	None		
C:	None		
D:	None		
Channel	Sensor	Desc	
A:	6233C-50 with 539	LPT	
B:			
C:			
D:			
Edit Conds	Speeds	Limits	

17. If you choose to continue with DATA ACQUISITION, go to step D. 4. below.

D. Data Acquisition

1. If the analyzer is off, turn the analyzer ON by pressing the ON/OFF key. At the MAIN MENU, select VIBRATION SPECTRUM SURVEY and press ENTER.

Model 4040 VIPER Analyzer			
Main Menu			
Propeller Balance			
Main Rotor Track & Balance			
Tail Rotor Balance			
Vibration Spectrum Survey			
Fan/Turbine Balance			
Fan Blade Optimizer			
Overall Vibration Survey			
Transient Vibration Survey			
IFE731 Performance - EMS			
Monitor Spectrum			
Monitor Magnitude and Clock			
Monitor Magnitude and Phase			
Monitor Overall			
Check Track			
Test Tach Power			
Miscellaneous Items			
Show Forms			

2. At the VIBRATION SPECTRUM SURVEY JOBS menu, select START JOB and press ENTER.

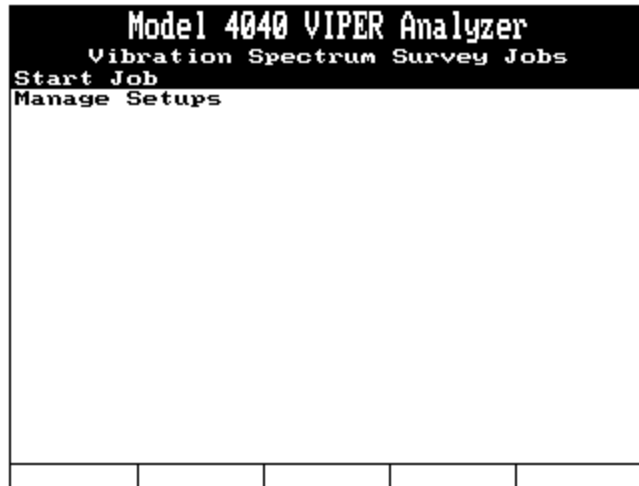

3. At the SETUP LIST menu, select CF6-50 SB 72-1313 and press ENTER.

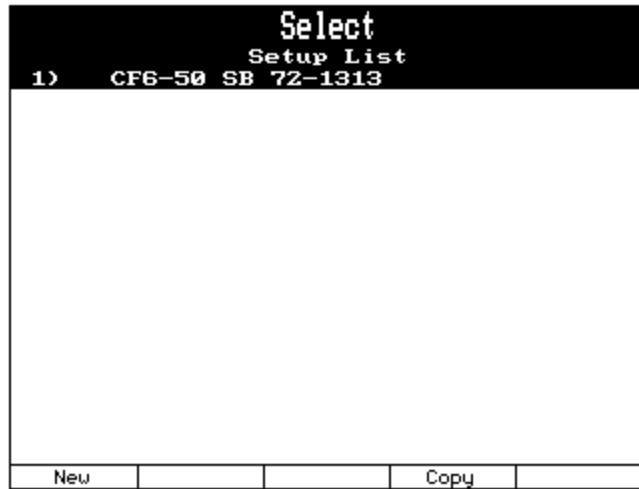

4. At the JOB IDENTIFICATION menu, use the analyzer keypad to enter the customer name, Aircraft Registration and Total time. When complete, press ENTER to continue.

Model 4040 VIPER Analyzer				
Job Identification				
Name: <input type="text" value="Unnamed"/>				
A/C Registration: <input type="text"/>				
A/C Total Time: <input type="text" value="0.0"/>				
Press ENTER to continue				
Names				

- At the ENGINE INFORMATION menu, select the engine POSITION number. Ignore the "Propeller:" Portion of the screen and enter ENGINE INFORMATION for the engine. When complete, press ENTER to accept and continue.

Model 4040 VIPER Analyzer				
Engine Information				
Position: <input type="text" value="1"/>				
Propeller:				
S/N <input type="text"/>				
Type <input type="text"/>				
TSO <input type="text" value="0"/>				
TSN <input type="text" value="0"/>				
Engine:				
S/N <input type="text"/>				
Type <input type="text"/>				
TSO <input type="text" value="0"/>				
TSN <input type="text" value="0"/>				
Serial Nos				

- At the Start Engine screen, start the engine(s) in accordance with the applicable AMM or the CF6-50 EM, 72-00-00, testing 003, TASK 72-00-00-700-003. Allow the engine to warm up to normal operating conditions then Press ENTER to continue.

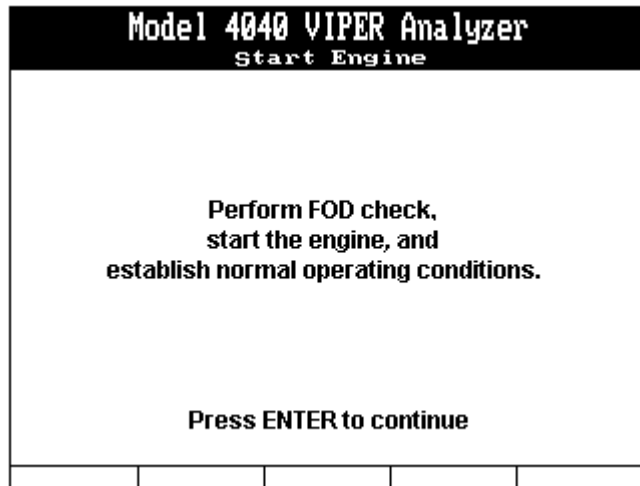

7. Increase engine N2 speed to 8,250 RPM (84% N2) and hold N2 speed for a five minute engine warm-up.
8. At the end of the five minute warm up, decrease engine speed to ground idle (GI) and prepare for the slow acceleration vibration survey.
9. At the SELECT CONDITION screen, use the [↑] [↓] keys to select the condition "ACCEL #1" (Acceleration number 1) then press ENTER.

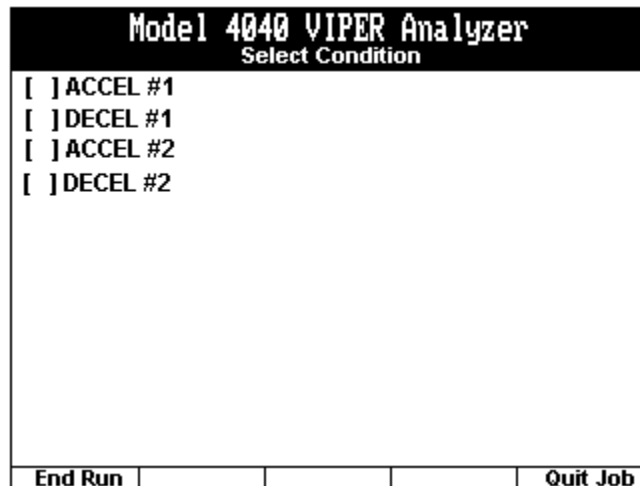

10. Wait for the Spectral Display screen (illustrated below) to appear on the analyzer screen. Begin a slow (not less than one minute) acceleration from ground idle (GI) to 8,250 RPM (84%) N2 . The Heavy dark line on the spectral display is the limit line at 5 mils and may be used as an instant reference if amplitude is exceeding 5 mils. When you reach 8,250 RPM, allow the engine to stabilize for five seconds then press [ENTER] to stop data collection.

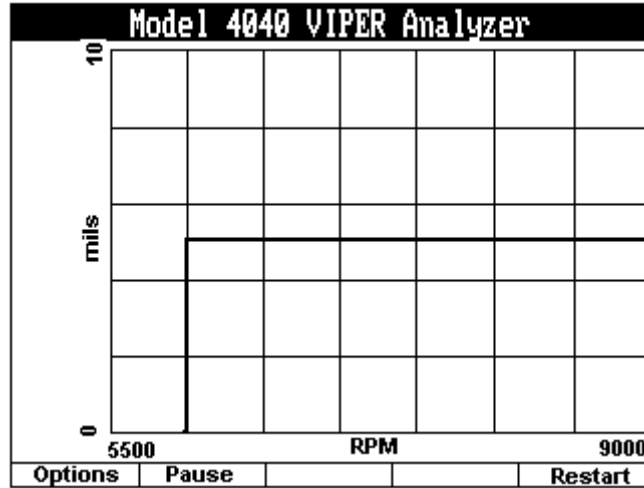

11. The screen will display the message “Store the data? Press the [F1] “Yes” key to store the data and continue.

Model 4040 VIPER Analyzer				
Store the data?				
Yes				No

12. The SELECT CONDITION menu will once again be displayed. Repeat step D. 9, 10 and 11. Above for the DECEL condition.

Model 4040 VIPER Analyzer				
Select Condition				
<input checked="" type="checkbox"/>	ACCEL #1			
<input type="checkbox"/>	DECEL #1			
<input type="checkbox"/>	ACCEL #2			
<input type="checkbox"/>	DECEL #2			
End Run				Quit Job

13. Allow the engine to stabilize at ground idle (GI) for five minutes then repeat steps D.9 thru D.11 above again for the second acceleration and deceleration.
14. Allow the engine to stabilize for three minutes at ground idle (GI) then shutdown the engine in accordance with the CF6-50 EM, 72-00-00, TESTING 012, TASK 72-00-00-700-012.

F. Quit Job

1. When all requirements are complete for ACCELERATION and DECELERATION surveys, press the [F5] “Quit Job” key from the screen example shown in D. 12. above.
2. Transfer the collected data to AvTrend per instructions provided in the 4040 Users manual using the USB cable to connect the analyzer to your PC or lapton. Once stored, you may email, print or view the data.

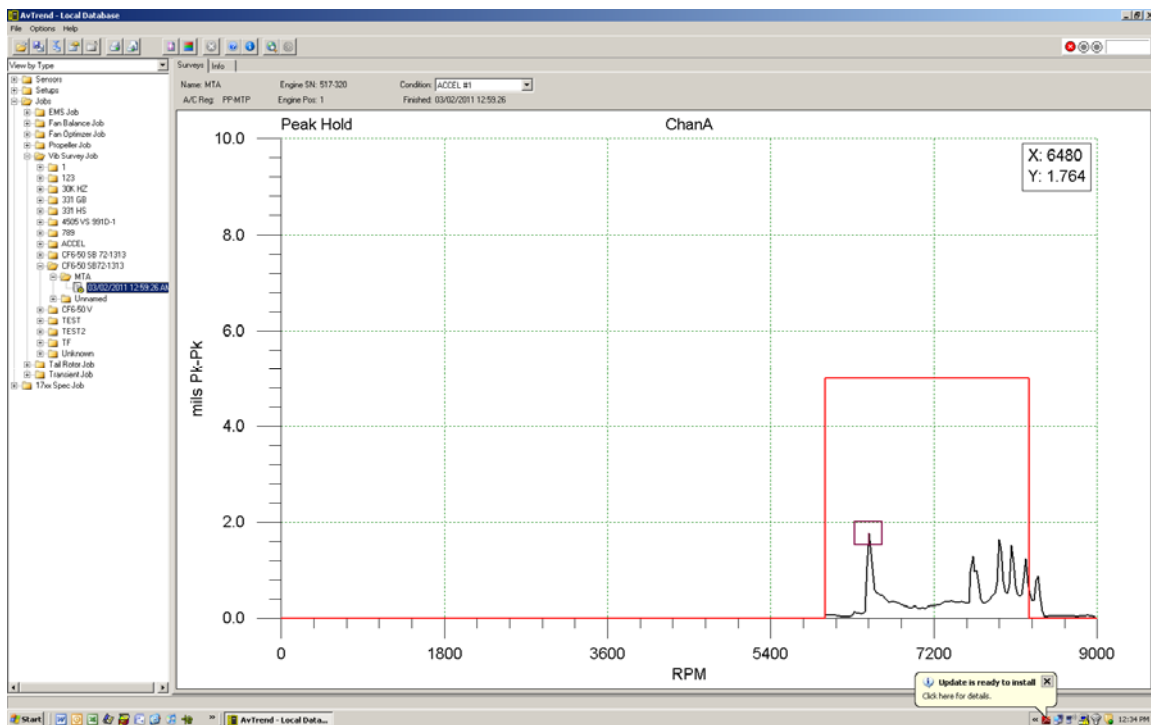

Figure 5. AvTrend view of an acceptable S.B 72-1313 Survey. Note the red limit line.