



Application Note

Application Note Number	E-HOT53-L13B-2020-SG
Version	0
Function	T-53 Spur Gear Survey
Airframe	N/A
Engine	Honeywell T-53
E-Setup Number	E-AST53-L13B-2020-SG.asf
ACES Systems Analyzer	2020 ProBalancer
Firmware Version	2.0 or greater
Procedure	N/A

Introduction

This outline covers the required equipment, installation, analyzer setup, and data acquisition process for using the ACES Systems' Model 2020 ProBalancer Analyzer for Spur Gear Analysis on the Honeywell / Allied Signal T-53-L-13B series turboshaft engine. General instructions for the use of the Model 2020 can be found in user manual #2020OM-01. All maintenance actions should be performed in accordance with Allied Signal Service Bulletin T-53-L-13B-0100.

A. Required Equipment

The following ACES Systems' equipment is required.

Item	Quantity	Description	TEC Part Number
1.	1	Model 2020 Analyzer	10-100-2020
2.	1	Mount, Sensor	LTCT535
3.	1	Cable, Sensor, 50'	10-320-0163
4.	1	Sensor, 991D-1	69-100-0075

Optional Equipment

No optional equipment required.

Miscellaneous Equipment

No optional equipment required.

B. Equipment Installation

1. Modify LTCT535 sensor mount as described in Service Bulletin T53-L-13B-0100.
2. Install LTCT535 sensor mount on the lifting eye on top of the engine inlet housing.
3. Install 991D-1 (P/N 69-100-0075) sensor into mount. Connect sensor cable (P/N 10-320-0163) to sensor and route to analyzer location.
4. Connect sensor cable (P/N 10-320-0163) to channel A on the 2020 ProBalancer Analyzer.

Equipment Installation Diagram

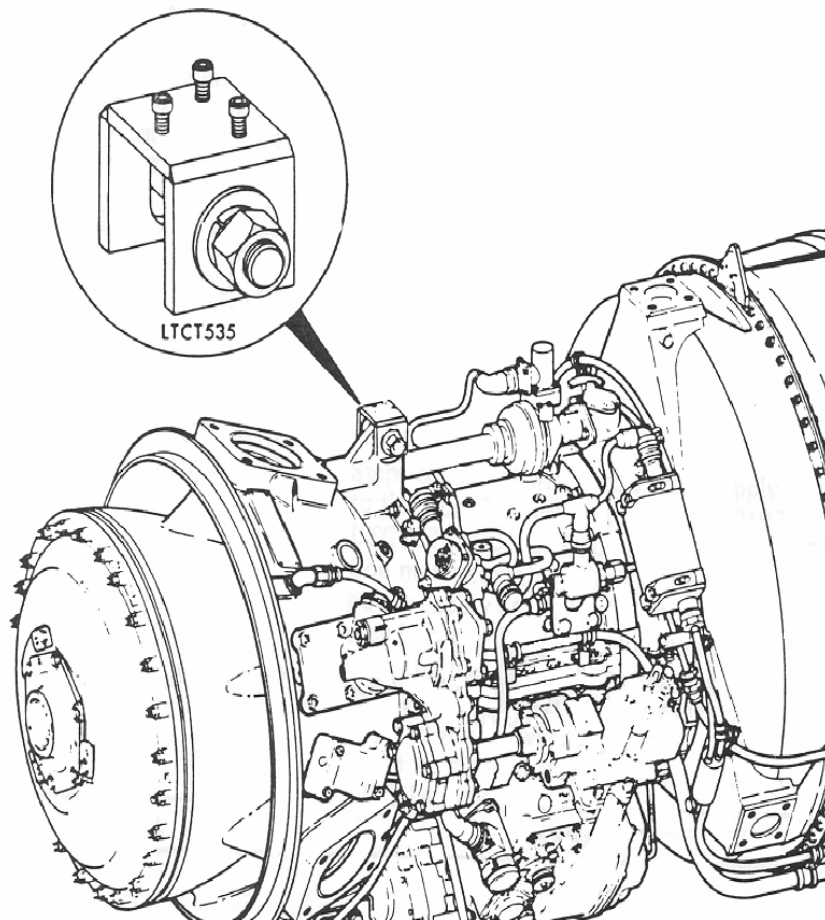

- The “Spectra Setup” screen will now appear. Using the example to the right as a guide, enter the survey information as shown in the appropriate fields. When finished, press **[F-1]** “Edit Conds” to move to the next screen.

Model 2020 ProBalancer	
Spectra Setup	
Name:	T-53 SPUR GEAR
Min Frequency:	3333.00
Max Frequency:	5000.00 (Hz)
Resolution:	(400) lines
Average Type:	(Normal)
Blocks in Avg:	4
Measure Inputs:	(A)
Channel A Desc:	
Channel B Desc:	
Vibration:	(IPS) Mod: (Peak)
Full Scale Vibration:	(1.00)
Sensor:	(991D-1)
Edit Conds	

- The “Spectra Conditions” screen appears. Under the “Condition” column, enter a name for vibration points to be acquired. To the right of each condition, enter the corresponding target N1 and N2 values. The N1/N2 values may be expressed in either percentage or RPM, as our example shows. These figures will serve as a guide in setting the proper engine condition prior to acquiring each point. Refer to the Service Bulletin for the number of test points and the N1 / N2 values to use.

Model 2020 ProBalancer			
Spectra Conditions			
	Condition	N1	N2
1)	6200 RPM	90	94
2)	6400 RPM	85	97
3)	6400 RPM	90	97
4)	6300 RPM	95	95
5)	6400 RPM	95	97
6)	6500 RPM	95	98
7)	6400 RPM	100	97
8)	6600 RPM	90	100
9)		0	0
10)		0	0

- When completed, press **[Enter]** once to return to the “Spectra Setup” screen. Press **[Enter]** again to save the setup.

- The “Engine Information” screen will appear next. You may enter this optional engine information and press **[Enter]** or skip this step by simply pressing **[Enter]**. If you have used the analyzer prior to this job, you will be able to recall a list of serial numbers to select from by pressing the **[F-1]** “Serial Nos.” key.

Model 2020 ProBalancer	
Engine Information	
Engine 1 Info	Prop 1 Info
S/N: 12345	N/A
Type:	
Pos: (1)	
TS0: 1250	
TSN: 1250	
Serial Nos	

- The “Select Aircraft Condition” screen appears as shown to the right. To acquire a measurement, select that condition and press **[Enter]**.

Once a condition has been measured, an “x” will be placed in the box preceding the point name. You may select to re-measure a condition if you so desire, the information previously stored will then be written over.

Model 2020 ProBalancer		
Select Aircraft Condition		
<input type="checkbox"/>	6200 RPM	N1=90 N2=94
<input type="checkbox"/>	6400 RPM	N1=85 N2=97
<input type="checkbox"/>	6400 RPM	N1=90 N2=97
<input type="checkbox"/>	6300 RPM	N1=95 N2=95
<input type="checkbox"/>	6400 RPM	N1=95 N2=97
<input type="checkbox"/>	6500 RPM	N1=95 N2=98
<input type="checkbox"/>	6400 RPM	N1=100 N2=97
<input type="checkbox"/>	6600 RPM	N1=90 N2=100
End Run		Quit Job

- After selecting a condition to measure, the data acquisition screen appears as shown to the right. The overall vibration for each sensor channel is shown in the upper right hand corner of each display. Use the cursor functions as described in Chapter 16, “Reading Spectrum and Scales” of the Model 2020 user’s manual to identify any peaks within the spectra. When finished measuring the current point, press **[Enter]** to stop data acquisition.

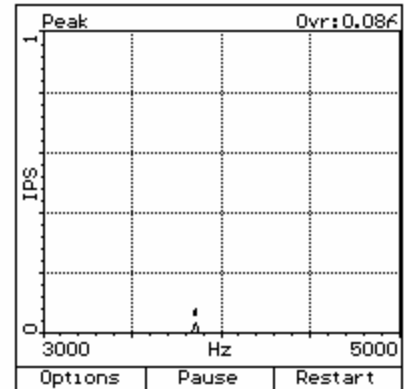

9. After pressing **[Enter]**, data acquisition will stop and a “Storage Confirmation” screen will be presented to allow the actual N1 and N2 values to be recorded and prompt you to store the data. If you wish to record N1 / N2, simply enter the value in the appropriate field. When completed, press **[F-1]** to store the data, or press **[F-3]** to exit without saving.

Model 2020 ProBalancer		
Enter actual N1:	<input type="text" value="90"/>	
Enter actual N2:	<input type="text" value="94"/>	
Store the spectral data?		
Yes		No

10. At this point, you will be returned to the “Select Aircraft Condition” screen as detailed in paragraph “7” of this section. From there, select another point to measure or exit the survey.

Model 2020 ProBalancer			
Select Aircraft Condition			
[x]	6200 RPM	N1=90	N2=94
[]	6400 RPM	N1=85	N2=97
[]	6400 RPM	N1=90	N2=97
[]	6300 RPM	N1=95	N2=95
[]	6400 RPM	N1=95	N2=97
[]	6500 RPM	N1=95	N2=98
[]	6400 RPM	N1=100	N2=97
[]	6600 RPM	N1=90	N2=100
End Run			Quit Job

11. Once all of the conditions have been acquired, the following screen will appear. Press **[Enter]** to continue. The analyzer will go back to the “Vibration Spectrum Survey” menu. Select and Press “Manage Jobs” and then select and press “Review Jobs”.

Model 2020 ProBalancer		
Out of conditions		
All defined conditions have been acquired.		
Press ENTER to continue.		

12. Select the job to review and press [Enter].

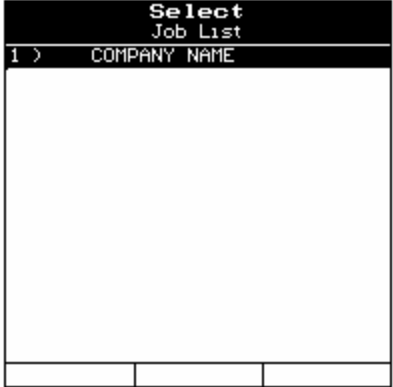

13. Select the condition to view and press [Enter]. The spectral plot for the selected condition will now be displayed. To view another condition, press [Enter], select the new condition and press [Enter] again.

Model 2020 ProBalancer			
Select Aircraft Condition			
[x]	6200 RPM	N1=90	N2=94
[x]	6400 RPM	N1=85	N2=97
[x]	6400 RPM	N1=90	N2=97
[x]	6300 RPM	N1=95	N2=95
[x]	6400 RPM	N1=95	N2=97
[x]	6500 RPM	N1=95	N2=98
[x]	6400 RPM	N1=100	N2=97
[x]	6600 RPM	N1=90	N2=100

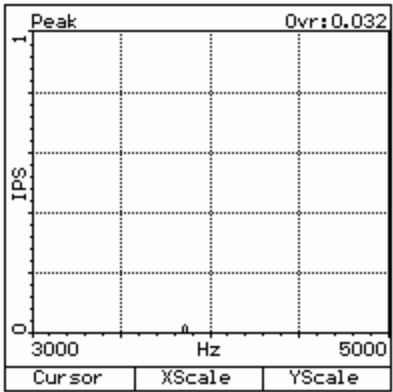



Application Note

Honeywell/Allied Signal T-53-L-13B Series

Spur Gear Vibration Survey

Part Number: 11-200-0157

AppNote Number: E-HOT53-L13B-2020-SG

This Application Note is provided for information only and does not supercede the requirements or guidelines set forth in the applicable engine or airframe maintenance manual. Technology for Energy Corporation assumes no obligation or liability, either express or implied, to the Purchaser arising out of the use of this procedure.

Copyright ? 2002, TEC Aviation Division. All rights reserved. This document is to be printed and reproduced for personal use only.

