



Application Note

Hélicoptères Guimbal Cabri G2

Tail Rotor Balance

Part Number: 11-200-0309

AppNote Number: A-HGG2-4040-TR (Rev. 3.01, Sep 2011)

This Application Note is provided for information only and does not supersede the requirements or guidelines set forth in the applicable engine or airframe maintenance manual. Technology for Energy Corporation assumes no obligation or liability, either expressed or implied, to the Purchaser arising out of the use of this procedure.

Copyright © 2011, TEC Aviation Division. All rights reserved. This document is to be printed and reproduced for personal use only.



Application Note

Application Note Number	A-HGG2-4040-TR
Revision	3.01 (From Preliminary Airframe Issue 04(2))
Function	Tail Rotor Balance
Airframe	Hélicoptères Guimbal Cabri G2
Engine	N/A
E-Setup Number	a-hgg2-4040-tr.asf
ACES Systems Analyzer	Model 4040
Boot/App Version	3.xx/3.xx or later
Procedure	N/A

Introduction

This Application Note covers the required equipment, equipment installation, analyzer setup, data acquisition and solution process for using the ACES Systems Model 4040 with the Tail Rotor Enhanced Performance Option to perform a tail rotor balance on the Hélicoptères Guimbal Cabri G2. General instructions for the use of the Model 4040 can be found in the Model 4040 User Manual #4040-OM-01 (P/N 75-900-4040). All procedures for balance and all adjustments should be made in accordance with the Airframe Maintenance Manual.

A. Required Equipment

The following equipment is required to perform a Tail Rotor Balance*:

Item	Quantity	Description	Part Number
1.	1	Analyzer, Model 4040CE	10-100-4040CE
2.	1	Tachometer, Optical, PhotoTach (New)	10-100-1773
3.	1	Cable, Tach, Generic, 50'	10-320-0126
4.	1	Sensor, Vibe, Accel, 991D-1	69-100-0075
5.	1	Cable, Sensor 991D-1, 50'	10-320-0163
6.	1	Tape, Reflective, Roll, 10'	10-400-0176
7.	1	Option, 4040 Main and Tail Rotor	11-900-0005

*This listing shows the latest design parts. It is acceptable to perform this task using previous designs with the appropriate accessories. For compatibility issues, contact ACES Systems.

Optional Equipment

The following equipment may be used as an alternate when accomplishing the job:

Item	Quantity	Description	Part Number
8.	1	Shield, PhotoTach Sun	22-430-0096

Miscellaneous Equipment

Available from Hélicoptères Guimbal:

Tail Rotor Gearbox Topper Support and Accelerometer Support under P/N G83-00-200

Tape or tie wraps to secure cables to airframe.

If adjustments are to be made to the Tail Rotor Balance, use only hardware or balance weights that are specified in the applicable airframe maintenance manual.

B. Equipment Installation

1. Park the aircraft on a flat level surface with the nose into the wind. Place the analyzer ([Item 1](#)) in the flight compartment.

NOTE

See [Paragraph D.2 below](#) for additional installation instructions of PhotoTach and Tape.

2. Mount Tach Source ([Item 2](#)) and Vibration Sensor ([Item 4](#)) ([Figure 1](#)) using Hélicoptères Guimbal Tail Rotor Gearbox Topper Support P/N G83-00-200.

NOTE

Secure and route cables as not to interfere with hot or rotating components and aircraft controls.

3. Install 50' Tach Cable ([Item 3](#)) by connecting the end of the cable identified as "TACH INTERFACE" to the PhotoTach. Safely route the cable to the location of the analyzer. Connect the end of the cable identified as "ANALYZER" to the "TACH 1" connector on the analyzer.
4. Install 50' Vibe Sensor Cable ([Item 5](#)) by connecting the end of the cable identified as "991D-1" to the Vibration Sensor. Safely route the cable to the location of the analyzer. Connect the end of the cable identified as "2020" to the "CHANNEL A" connector on the analyzer.
5. Reinstall any previously removed cowlings.

Equipment Installation Diagram

Figure 1

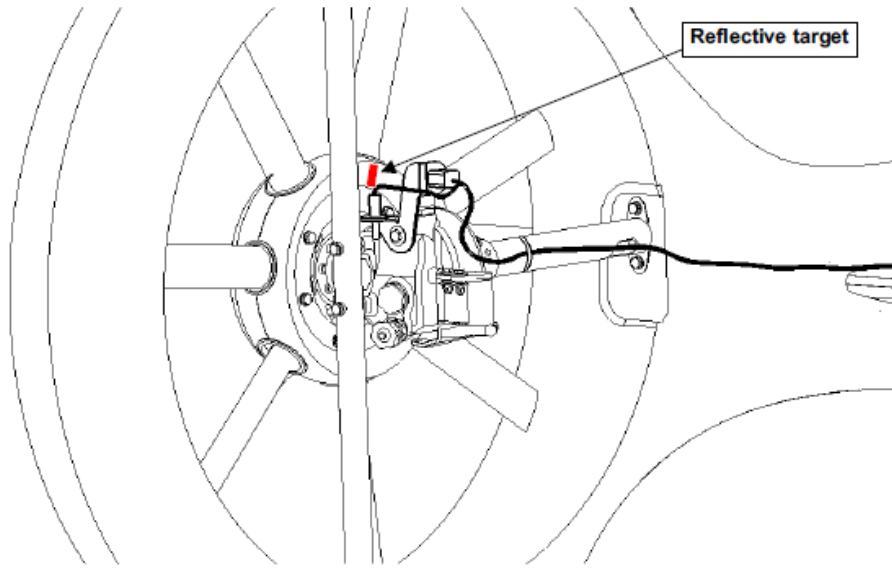
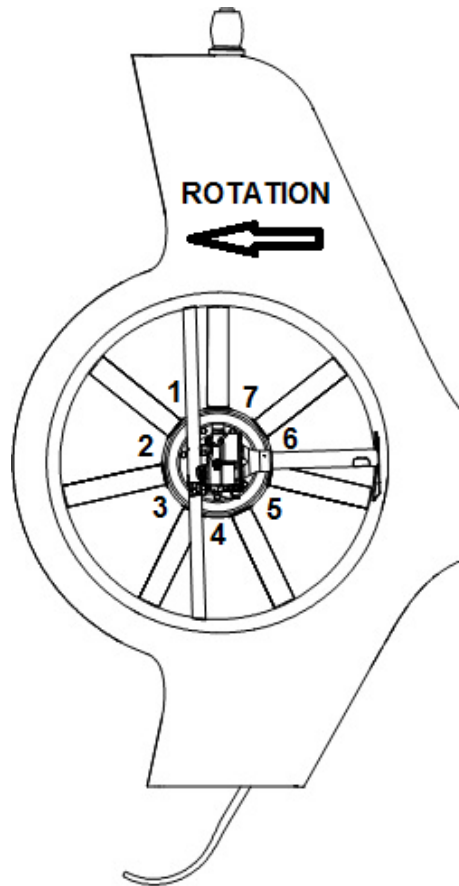
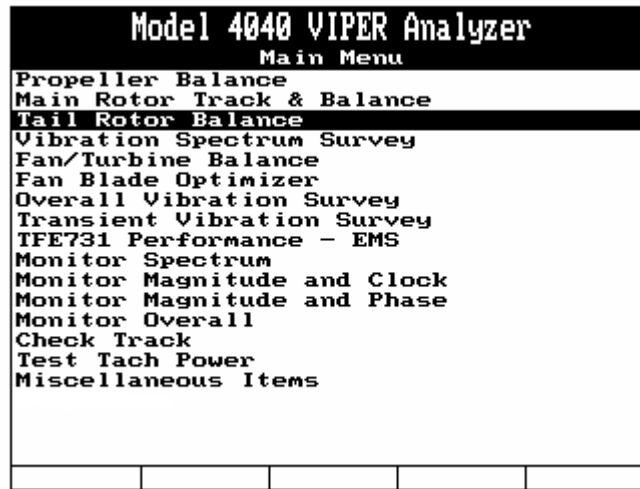

Figure 2



C. Analyzer Set Up

1. Insure the analyzer battery is charged prior to starting the job. See the Model 4040 User Manual #4040-OM-01 (P/N 75-900-4040) Chapter 2 for detailed instructions on battery charging.
2. Turn the analyzer ON by pressing the [ON/OFF] key.
3. From the Main Menu shown below, select “Tail Rotor Balance” and press the [ENTER] key.



4. From the Tail Rotor Balance Menu shown below, select “Start Job” and press the [ENTER] key.

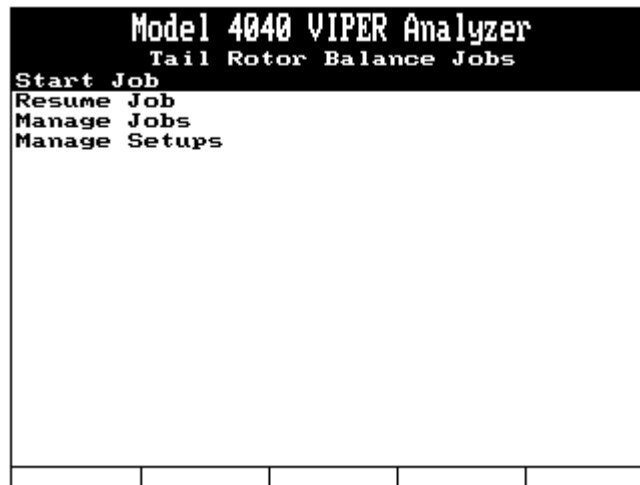

5. If the setup for the Hélicoptères Guimbal Cabri G2 is listed in the Setup List, select it using the [↓] key, press [ENTER] and go to [Section D below](#). If the setup for the Hélicoptères Guimbal Cabri G2 is not in the Setup List, press the [F1], “New” key and go to [Step 6 below](#).

Model 4040 VIPER Analyzer				
Tail Rotor Chart Setup				
Name:	a-hgg2-4040-tr			
Chart Type:	Regular	Num WtPos:	7	
Grams/IPS:	3.000			
WtPos	Add @	WtPos	WtPos	
1	12 : 21			
2	2 : 04			
3				
4				
5				
6				
7				
WtPos MUST be in CW or CCW order				

D. Data Acquisition

- The “Job Identification” screen will be displayed, as shown below. Use the analyzer keypad to enter a customer name in the “Name:” field. The analyzer will maintain a list of customer names as new names are entered. If names have been previously entered into this analyzer, you may press the [F1] “Names” key and select a customer’s name from the provided list. Press the [↓] key to move to the next field and use the analyzer keypad to enter the optional aircraft registration and aircraft total time as required. When all fields are complete, press the [ENTER] key to accept and continue.

Model 4040 VIPER Analyzer				
Job Identification				
Name:	HELICOPTER GUIMBAL			
A/C Registration:	F-WVHG			
A/C Total Time:	123.4			
Press ENTER to continue				
Names				

- The next screen to be displayed will be the “Connect Sensors” screen as illustrated below. This screen gives instructions on installing sensors and cables. You may also check the PhotoTach alignment by pressing the [F1] “Tach Pwr” key which supplies power to the optical tachometer for checking alignment with the reflective tape.

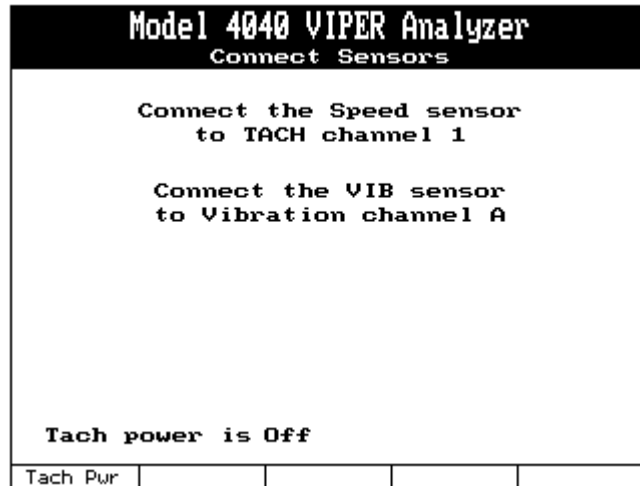

- 2.1 Press **[F1]** “Tach Pwr”. Select a blade to be identified as the target blade. (See Section B [Figure 2](#) above)
- 2.2 Hold a 2-inch piece of reflective tape ([Item 6](#)), reflective surface facing the PhotoTach, against the backside of the hub. Do not remove backing at this point.
- 2.3 The red “Gate” light on the back of the PhotoTach should illuminate as the reflective tape is properly aligned in front of the LED. Clean an area of the hub in preparation for mounting the reflective tape.
- 2.4 Remove the backing and install the reflective tape on the clean hub surface.
- 2.5 Adjust the PhotoTach to obtain an angle of approximately 5 degrees from perpendicular to the reflective tape. This will produce the best results when reading RPM.
- 2.6 Press **[ENTER]** when finished with Tape installation. This will automatically supply power to the PhotoTach regardless of the “Tach Power” condition at the bottom of the screen.
3. The “Start Aircraft” screen will be displayed with instructions to “Perform FOD check and start aircraft per flight manual”. When the aircraft is started and normal operating conditions have been established, press the **[ENTER]** key to continue. Use the **[F2]** “Swap Job” key to return directly to the Main Menu without rebooting the analyzer.

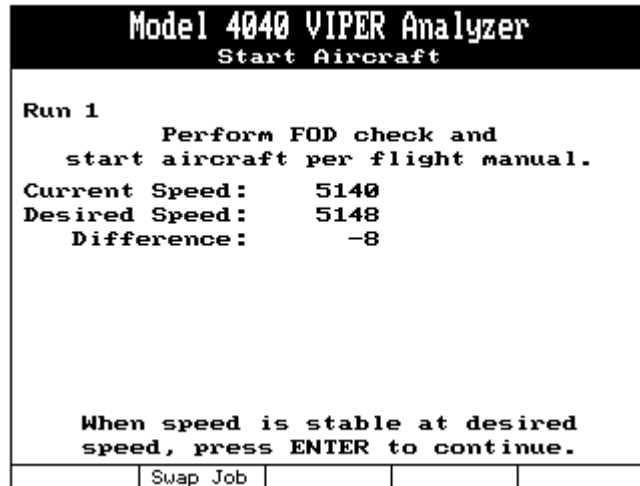

4. The analyzer will present the data acquisition screen as shown below. This screen allows you to monitor both the current and averaged vibration readings. Operate the aircraft in the configuration for the selected condition and allow the analyzer to collect data. While monitoring the measurement, you may press the [F1] “Reset” key to restart the averaging process. Use this feature as a way to validate the quality of the measurement. If the averaged readings return to a value similar to the displayed value prior to being “Reset”, the measurement can be considered good. If the measurement is not similar, you may choose to “Reset” the average again. If the “Error” at the bottom of the text portion of the screen is not “0”, this is not an indication of failure or fault, only that the vibration averaging errors cannot be resolved below the displayed level. This “Error” value will typically be higher as the balancing process reduces the vibration amplitude. The “Error” indication should be as steady as possible with very little change before you press the [ENTER] key to stop acquisition.

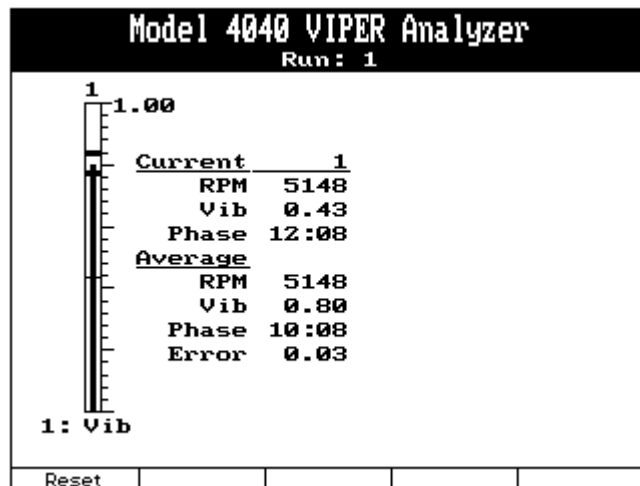

See the Model 4040 User Manual #4040-OM-01 (P/N 75-900-4040) Chapter 20 for detailed instructions on how to read the “Converging Vibration Indicator and Scale.”

5. You will be prompted to “Shut down engine(s) per manual instructions” as shown below. Use the [F2] “Swap Job” key to return directly to the Main Menu without rebooting the analyzer. Press [F5] to proceed after engine shut down.

Model 4040 VIPER Analyzer			
Shut Down Engines			
Shut down engine(s) per manual instructions			
Swap Job			Continue

6. The “Review Prior Run(s) Data” screen will appear. This screen allows the user to view the vibration readings that were acquired during the condition. Press [F1] to “Retake (Run #)” data by returning to [Step 3 above](#). Press [F5] “Quit Job” to complete the entire job with no way to resume it in the future. Press [ENTER] to continue to the weight suggestions.

Model 4040 VIPER Analyzer			
Review Prior Run(s) Data			
Run	RPM	IPS	Clock
1	5148	0.800	10:08
Retake #1			

CAUTION

At no point should a correction be made that contradicts information in the maintenance manual.

The analyzer will attempt to resolve the vibration and/or track level to 0.00. This may require adjustments that are not practical to duplicate. The technician must determine the closest possible match to the suggestion.

7. The “T/R Suggested/Installed Weights” screen will present a suggested solution based on the chart created in the original setup and the vibration IPS and clock reading. You have the opportunity to install the suggested weight corrections or decide on a different corrective action. It is important that the entry under the “Enter Installed Wts” reflect the actual weight

amounts and locations used.

To install the suggested weights use [F1] “Inst=Sugg” key. To remove all values in the suggested column use the [F2] “Inst=None” key.

The [F5] “Quit Job” exits the balance job with no provisions to resume the job at a later point in time. If you wish to leave the job and be able to resume it later, press the [MAIN MENU] or [REBOOT] or [ON/OFF] key.

Using the keypad, record the actual weight(s) installed between runs and their location. If you choose to remove weight from an opposite or alternate position, enter the negative adjustment. Do this by moving the highlight to the appropriate field, press the [SPACE+/-] key to produce a (-).

Using the screen below as an example, the suggested weight installation is to add 0.8 grams to the #6 weight hole location and to add 1.8 grams to the #7 weight hole location. This is shown on the top line of the screen, directly below “Run 1 Suggestion:”

Only 0.7 gram and 2.0 gram counterbalance weights are available for balancing. In the example below, the closest matching weight combination was to add 0.7 grams to the #6 weight hole location and to add 2.0 grams to the #7 weight hole location. This change was made on the tail rotor and entered into the analyzer adjacent to the appropriate weight hole locations under the “Enter Installed Wts” portion of the screen.

Model 4040 VIPER Analyzer			
T/R Suggested/Installed Weights			
Run 1 Suggestion:			
Chart: a-hgg2-4040-tr			
6	0.8	7	1.8
Enter Installed Weights:			
1	0.0		
2	0.0		
3	0.0		
4	0.0		
5	0.0		
6	0.7		
7	2.0		
Inst=Sugg	Inst=None		Quit Job

- When you have finished with the solution process, press [ENTER] and you will be taken to the “Start Aircraft” screen as shown in [Paragraph 3](#) of this section to continue the balance process.

E. Quit Job

- Repeat [Steps D.3](#) through [D.8 above](#) applying the solutions as necessary. When you are satisfied with the balance results, you can quit the job from any screen displaying the [F5] “Quit Job” key. This will mark the job as complete and take you to [Paragraph 2 below](#).

2. From this screen, decide if you would like to update the ICF used in the original setup. Pressing **[F1]** “Yes” will add the chart corrections from this job to the ICF from the original setup. This can be a powerful tool when using this setup in the future. The chart corrections learned as a result of the previous job will be applied from the beginning of the next job that uses the same setup. This can reduce the number of runs required to balance the helicopter. If you select **[F5]** “No” any chart corrections applied during the previous job will be discarded. The setup will revert to the chart settings in place before the job was started. This can be useful if the helicopter didn’t respond as others of the same model or if a mistake was made somewhere during the job that caused extra runs to balance the helicopter.

Model 4040 VIPER Analyzer				
Update Setup ICFs?				
Do you want to update the setup's influence coefficients based on the result of this job?				
Yes				No