



# Application Note

<b>Application Note Number</b>	A-ECAS365-4040-TR(3P)
<b>Revision</b>	0
<b>Function</b>	Fenestron Balance 3 Point
<b>Airframe</b>	AS365
<b>Engine</b>	N/A
<b>E-setup Number</b>	A-ECAS365-4040-TR(3P).asf
<b>ACES Systems Analyzer</b>	Model 4040
<b>Firmware Version</b>	1.00 or greater
<b>Procedure</b>	N/A

## Introduction

This Application Note covers the required equipment, equipment installation, analyzer setup, data acquisition and solution process for using the ACES Systems' Model 4040 to perform fenestron balance on the AS365 helicopter. General instructions for the use of the Model 4040 can be found in user manual #4040-OM. All procedures for track and balance and adjustments should be made in accordance with the Eurocopter Maintenance Manual.

## A. Required Equipment

The following ACES Systems' equipment is required.

Item	Quantity	Description	Part Number
1.	1	Model 4040 Analyzer	10-100-4040
2.	1	Phototach	10-100-1773
3.	1	Cable, Tachometer, 50 ft.	10-320-0126
4.	1	Sensor, Vibration, 991D-1	69-100-0075
5.	1	Cable, Sensor, 991D-1, 50'	10-320-0163
6.	1	Tail Rotor Photocell Bracket	22-430-0105
7.	1	Reflective Tape	10-400-0176

## Miscellaneous Equipment

Tape, tie wraps or cable clamps to secure cables to airframe.

## B. Equipment Installation

---

1. Park the helicopter on a flat surface with the nose facing into the wind.
2. Install sensor bracket (P/N 22-430-0105) to rear of tail gearbox at the 12:00 position. Install 991D-1 sensor (P/N 69-100-0075) in bracket ensuring that connector faces forward.
3. Install phototach (P/N 10-100-1773) into bracket and secure with nut.
4. Connect phototach cable (P/N 10-320-0126) to phototach and connect sensor cable (P/N 10-320-0163) to sensor and route cables into cabin area. Connect sensor cable to channel A of balancer. Connect phototach to Tach 1 channel of balancer.

### Note

**Route all cables as not to interfere with hot or rotating components.**

5. Apply a piece of reflective tape to aft side of the casing corresponding to balance point C which located 130 degrees from balance points A and B. Ensure the reflective target is in-line with the photocell.

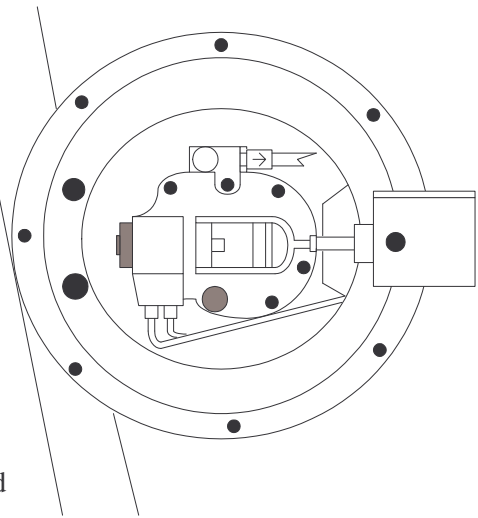

## C. Analyzer Set Up

1. Turn the analyzer “ON”
2. From the “Main Menu”, select “Tail Rotor Balance” and press [Enter]. From the “Tail Rotor Balance” menu, select “Manage Setups” and press [Enter]. From the “Manage Setups” menu, select “New” and press [Enter].
3. If setups are already stored in the analyzer, a setup list will be presented. If the AS365 is not among this list, press the [F-1] key for a “New” setup.
4. The “Tail Rotor Setup” screen now appears. Enter the tail rotor job setup information as shown in the appropriate fields. When completed, press [Enter].

Model 4040 VIPER Analyzer	
Tail Rotor Setup	
Name:	AS365
Sensor Chan:	(A)
Sensor:	(991D-1)
Tach Chan:	(1)
Tach Type:	(Optical)
Tach Pos:	(12)
Balancing RPM:	3600
Rotor Direction:	(CW)
Number of Blades:	11
Conditions:	1
Max Baln. Wts:	6.0

5. The Tail Rotor Chart screen now appears. Enter the setup chart influence information exactly as shown. When finished, press [Enter].
6. Setup complete. When finished press [Enter], [Backup], and [Start Job].

Model 4040 VIPER Analyzer				
Tail Rotor Chart Setup				
Name:	AS365			
Chart Type:	(Irregular)			
Num WtPos:	3			
WtPos	Grams	IPS	Add	Q
A	12.00	1.00	7	: 40
B	12.00	1.00	4	: 15
C	12.00	1.00	12	: 0
WtPos MUST be in CW or CCW order				

### Warning

It is important that the following setup information be entered exactly as shown, as errors may lead to possible failure of jobs performed with this setup.

## D. Data Acquisition

1. Turn the analyzer **[ON]**. From the “Main Menu”, select “Tail Rotor Balance” and press **[Enter]**. From the “Tail Rotor Balance” menu, select “Start a Job” and press **[Enter]**.
2. Next, select the AS365 setup from the analyzer’s setup list, select it and press **[Enter]**.

Select Setup List			
1	>	AS365	
2	>	AS350/355 D/S	
3	>	AS350/355	
4	>	MD500C/D/E OH-6	
5	>	EC-155	
6	>	MD500D 4 BLADE T/R	
7	>	500C/OH-6 T/R	
8	>	MD600 FAN	
New			Copy

3. The “Customer Information” screen appears. You may enter this optional customer information and press **[Enter]**. If you have used the analyzer prior to this job, you will be able to recall a list of names to select from by pressing the **[F-1]** “Names” key. It is recommended that you enter at least a customer name, as it will aid in recalling the data at a later date.

Model 4040 VIPER Analyzer Customer Information			
Enter the following optional customer information.			
Name:	:	CUSTOMER NAME	
A/C Registration:	:	N12345	
A/C Total Time:	:	1221	
Press ENTER to continue			
Names			

4. An equipment setup screen will appear next, directing you to install and connect the vibration sensor and tachometer sensor to the channels assigned in the job setup. Press **[Enter]** to continue.

Model 4040 VIPER Analyzer Tail Rotor Equipment Setup			
Install the speed sensor and connect to tach channel 1			
Install vibration sensor and connect to vib. channel A			
Tach power is off			
Tach On			

- The “Start Aircraft” screen as shown is presented next. This screen has an rpm monitor to allow verification of the tail rotor speed prior to acquiring data. When the rotor speed is as desired, press **[Enter]** to continue.

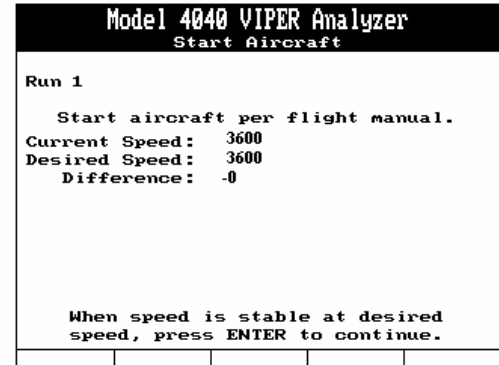

- The analyzer will present the data acquisition screen. This screen allows you to monitor both the current and averaged vibration readings. While monitoring the measurement, you may press the **[F-1]** “Reset” key to restart the averaging process. When the % error shown has reached its lowest point, press **[Enter]** to stop the acquisition process.

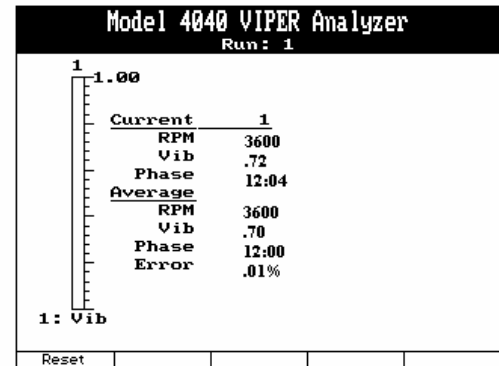

- The balancer will now display the imbalance reading . After review press **[Enter]**.

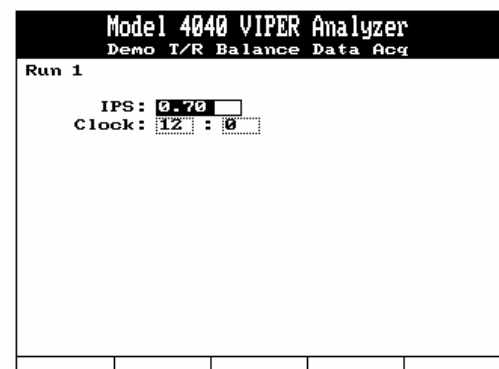

8. Shutdown aircraft and press **[Enter]**. The solution screen as shown will now present the recommended corrections for the current run.

Model 4040 VIPER Analyzer			
Shut Down Aircraft			
Shut Down Aircraft per flight manual instructions			
			Continue

9. The analyzer will now present the “Review Prior Run(s) Data”. If you wish to re-measure the data just acquired, you may press **[F-1]** “Retake”. If you wish to continue, press **[Enter]**.

Model 4040 VIPER Analyzer			
Review Prior Run(s) Data			
Run	RPM	IPS	Clock
1	2500	0.700	12:00
Retake #1			

10. The example shows the solution of adding 8.4 grams to Balance hole C. Record the actual weight installed between runs and its location. If you opt to remove weight from an opposite position, you may either enter a negative weight installation (by using the – sign) or leave the positive value in the original position. If you enter the negative value, you must erase the opposite value from the screen or the analyzer will total both values and the influence will be calculated incorrectly for the next run. To continue to the next run press **[Enter]**. If you wish to terminate the job, press the **[F-3]** “Quit Job” key and the job will be stored as completed. Using the quit job option will terminate the ability to re-start the job later. If you wish to leave the job and be able to restart it later, press the **[Main Menu]** key.

Model 4040 VIPER Analyzer			
T/R Suggested/Installed Weights			
Run 1	Suggestion:		
Chart:	AS365		
C	8.4		0.0
Enter Installed Weights:			
A	0.0		
B	0.0		
C	8.4		
Inst=Sugg	Inst=None		Quit Job

11. When you have finished with the solution process, you will be taken the “Start Aircraft” screen to start the next run.

```
Model 4040 VIPER Analyzer
Start Aircraft

Run 2

Start aircraft per flight manual.
Current Speed: 3600
Desired Speed: 3600
Difference: .0

When speed is stable at desired
speed, press ENTER to continue.
```

### Note

It is important to remember that when installing or removing weights and recording their positions that the influence used for the next run will be updated by the result from the previous run's solution, therefore be as accurate as possible when recording adjustments made regardless whether the recommended solution is implemented. The only entries on this screen should reflect the actual solution implemented.



# Application Note

---

## **Eurocopter AS365**

## **Tail Rotor (Fenestron) Balance**

---

Part Number: 11-200-0107

AppNote Number: a-ecas365-4040-tr3p

This Application Note is provided for information only and does not supercede the requirements or guidelines set forth in the applicable engine or airframe maintenance manual. Technology for Energy Corporation assumes no obligation or liability, either express or implied, to the Purchaser arising out of the use of this procedure.

Copyright © 2001, TEC Aviation Division. All rights reserved. This document is to be printed and reproduced for personal use only.