



Application Note

Eurocopter AS365/Harbin Z-9 Series

Main Rotor Track and Balance

Part Number: 11-200-0106

AppNote Number: A-EUAS365-4040-MR (Rev. 3.0, Jan 2011)

This Application Note is provided for information only and does not supersede the requirements or guidelines set forth in the applicable engine or airframe maintenance manual. Technology for Energy Corporation assumes no obligation or liability, either expressed or implied, to the Purchaser arising out of the use of this procedure.

Copyright © 2001 - 2011, TEC Aviation Division. All rights reserved. This document is to be printed and reproduced for personal use only.



Application Note

Application Note Number	A-EUAS365-4040-MR
Revision	3.0 (From Airframe Release 01/39)
Function	Main Rotor Track and Balance
Airframe	Eurocopter AS365/Harbin Z-9 Series
Engine	Various
E-Setup Number	a-euas365-4040-mr.asf
ACES Systems Analyzer	Model 4040
Boot/App Version	Boot 3.xx/App 3.xx or later
Procedure	N/A

Introduction

This Application Note covers the required equipment, equipment installation, analyzer setup, data acquisition and solution process for using the ACES Systems Model 4040 Viper Analyzer with the Main Rotor Performance Option to perform main rotor track and balance on the Eurocopter AS365/Harbin Z-9 Series. General instructions for the use of the Model 4040 can be found in the Model 4040 User Manual #4040-OM-01 (P/N 75-900-4040) and Optical Tracker Operational Supplement #540-OM-1 (P/N 75-900-2021). All procedures for track and balance and all adjustments should be made in accordance with the Airframe Maintenance Manual.

A. Required Equipment

The following equipment is required to perform a Main Rotor Track and Balance*:

Item	Quantity	Description	Part Number
1.	1	Analyzer, Model 4040CE	10-100-4040CE
2.	2	Sensor, Vibe, Accel, 991D-1	69-100-0075
3.	1	Cable, Sensor 991D-1, 25'	10-320-0162
4.	1	Cable, Sensor 991D-1, 50'	10-320-0163
5.	1	Cable, Magnetic Pick-Up, 25'	10-320-0052
6.	1	Sensor, Magnetic Passive Speed	75-900-0187
7.	1	Mount, ¼X28 Sensor, Vibe ¼" Hole, S/Stl	22-430-0035
8.	1	Mount, ¼X28 Sensor, Vibe 5/16" Hole, S/Stl	22-430-0036
9.	1	Tracker, Optical, Model 540-2	75-900-0542
10.	1	Option, 4040 Main and Tail Rotor	11-900-0005

11.	1	Mount, Mag P-UP, AS365 M/R	10-100-0497
-----	---	----------------------------	-------------

*This listing shows the latest design parts. It is acceptable to perform this task using previous designs with the appropriate accessories. For compatibility issues, contact ACES Systems.

Optional Equipment

The following equipment may be used as an alternate when accomplishing the job:

Item	Quantity	Description	Part Number
12.	1	Target Assy, Tip	As Required
13.	1	Cable, Interf. Assy, Strobe	10-320-0161
14.	1	Strobelight	As Required
15.	1	Mount, Vibe Sensor "Z"	22-430-0037

Miscellaneous Equipment

Tape or tie wraps to secure cables to airframe.

If adjustments are made to the main rotor balance, use only hardware or balance weights that are specified in the applicable airframe maintenance manual.

List of abbreviations

MCP - Straight and level flight at Maximum Continuous Power

MCP/30 - Flight at Maximum Continuous Power in a 30 Degree Bank

DEG - Degrees of Trim Tab Adjustment

PLT - Plates of Weight Adjustment

PCL - Pitch Change Link

Flt - Flats of adjustment, 1 Flt = 1/6 turn of PCL

B. Equipment Installation

- Place the analyzer ([Item 1](#)) in the flight compartment.
- Install the Magnetic Pickup Mount ([Item 11](#)) on the stationary swashplate, secure with wedge, nuts and screws. ([Figure 1](#)) Rotate the Main Rotor until the Magnetic Pickup Mount and Interrupter are aligned as shown. ([Figure 2](#)) Install the Magnetic Pickup ([Item 6](#)) into the Mount. Adjust gap between Magnetic Pickup and interrupter to .049 +/- .010. Secure pickup with jam nuts and safety wire. The blade at the 1:30 location will become "BLACK" for balancing. The static location of this blade determines the "Aiming Point" for track acquisition. The remaining blades will be identified as, "BLUE", "YELLOW", "RED", in passing order as shown below. ([Figure 2](#))

NOTE

Interrupter should be permanently installed on the swashplate. Ensure that the Black Blade is positioned at the 1:30 position when the Magnetic Pickup and interrupter are aligned.

3. Install the Sensor Mount (Item 7) on the left hand side of the center console on the fuse box cover. Install a 991D-1 Sensor (Item 2) in the Mount, **ensure connector end of Sensor faces down**. This will become the Vertical Vibration Sensor. (Figure 3)
4. Install the Sensor Mount (Item 8) on the 9 degree frame. (Alternate installation: install the Sensor Mount (Item 15) on the 0 degree frame) Install a 991D-1 Sensor (Item 2) into the Mount, **ensure connector end of the Sensor faces up**. (Figure 3)

NOTE

Secure and route cables as not to interfere with hot or rotating components and aircraft controls. Insure there is adequate slack in the cables to allow full cyclic and collective inputs.

5. Install Tach Cable (Item 5) by connecting the end of the cable identified as “MAG PICK-UP” to the Mag Pick-Up. Safely route the cable to the location of the analyzer. Connect the end of the cable identified as “ANALYZER” to the “TACH 1” connector on the analyzer.
6. Install Vertical Vibe Sensor Cable (Item 3) by connecting the end of the 25’ Sensor Cable identified as “991D-1” to the Vibration Sensor as installed in Step 3 above. Safely route the cable to the location of the analyzer. Connect the end of the cable identified as “2020” to the “CHANNEL A” connector on the analyzer.
7. Install Lateral Vibe Sensor Cable (Item 4) by connecting the end of the 50’ Sensor Cable identified as “991D-1” to the Vibration Sensor as installed in Step 4 above. Safely route the cable to the location of the analyzer. Connect the end of the cable identified as “2020” to the “CHANNEL B” connector on the analyzer.
8. Connect the Optical Tracker (Item 9) to the Aux./Comm port on the Analyzer.
9. Reinstall any previously removed cowlings. Return aircraft to flying configuration.

Equipment Installation Diagram

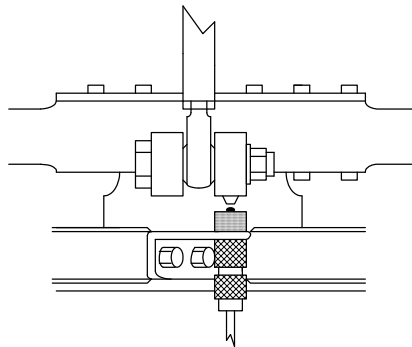
Figure 1

Figure 2

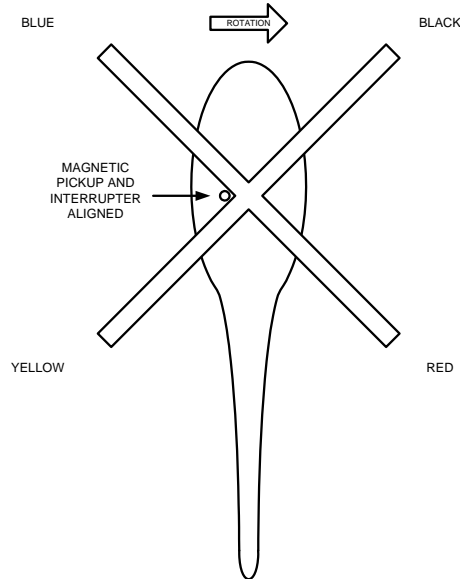
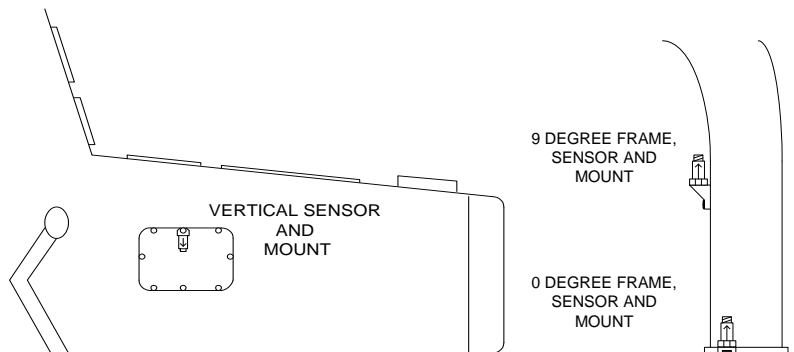


Figure 3

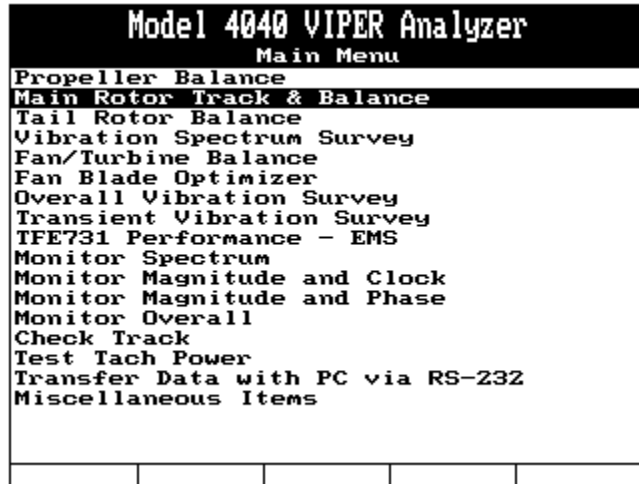


C. Analyzer Set Up

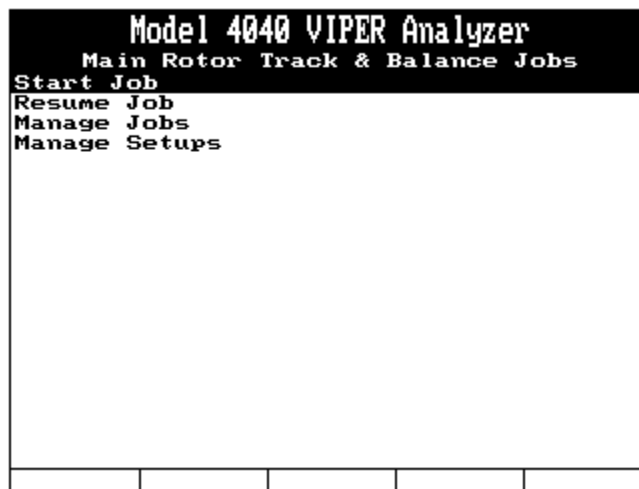
NOTE

The analyzer requires a different configuration when using English measurement units than when configured using metric measurement units. Where there is a difference the English configuration will be displayed on the left, the metric configuration will be displayed on the right.

1. Insure the analyzer battery is charged prior to starting the job. See the Model 4040 User Manual #4040-OM-01 (P/N 75-900-4040) Chapter 2 for detailed instructions on battery charging.
2. Turn the analyzer ON by pressing the [ON/OFF] key.
3. From the Main Menu shown below, select “Main Rotor Track & Balance” and press the [ENTER] key.



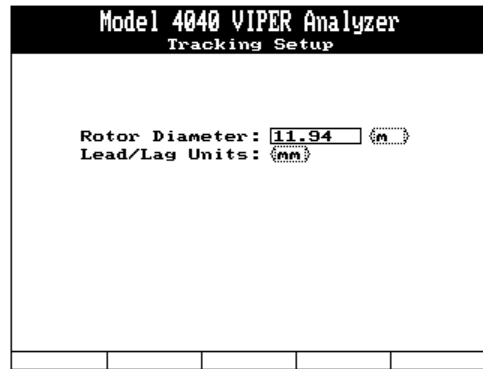
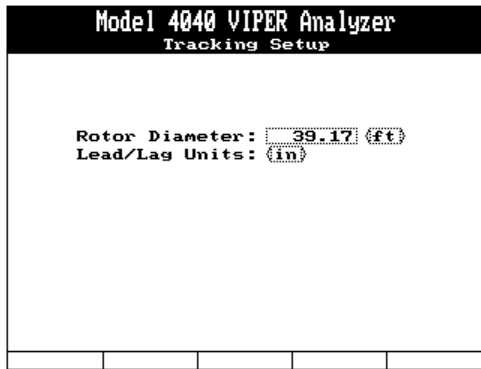
4. From the Main Rotor Track & Balance Menu shown below, select “Start Job” and press the [ENTER] key.



5. If the Eurocopter AS365/Harbin Z-9 Series is listed in the Setup List, select it using the [↓] key, press [ENTER] and go to [Section D below](#). If the Eurocopter AS365/Harbin Z-9 Series is not in the Setup List, press the [F1], “New” key and go to [Step 6 below](#).

English

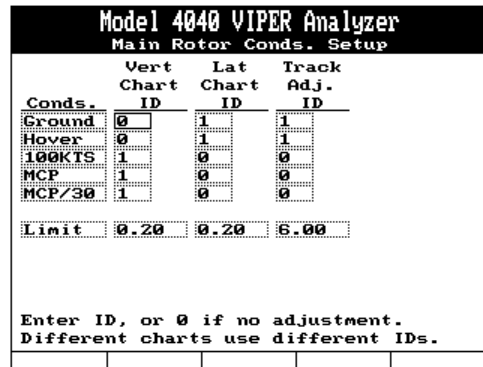
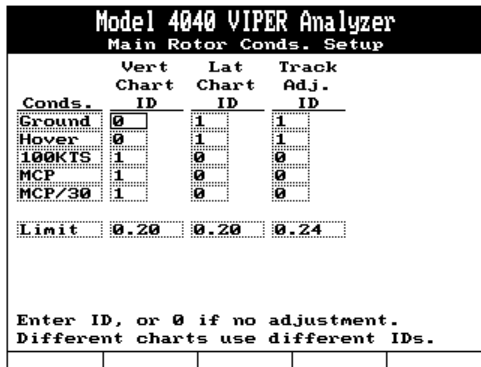
Metric



8. The “Main Rotor Conds. Setup” screen will appear next as displayed below. The “limit” field under each measurement type will set the point at which the analyzer will determine whether corrections are needed. This is not reflective of a limit imposed by the manufacturer. See the applicable Maintenance Manual for the track and vibration levels required for return to service. Enter the information as indicated in the illustration below. Press [ENTER] to continue.

English

Metric



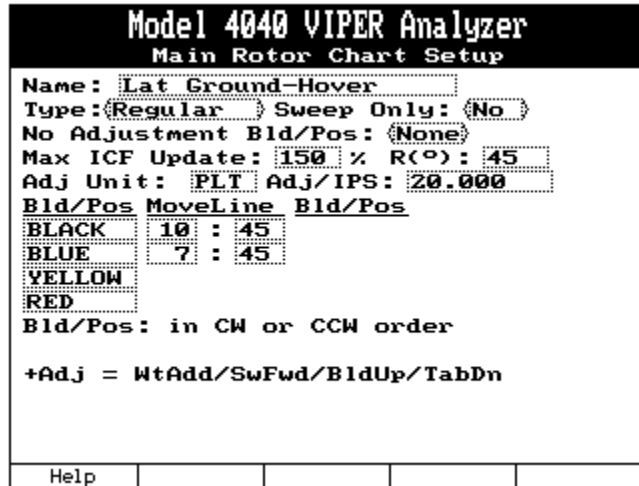
9. The next screen to appear will be the “M/R Adj Symbol & Soln Logic” screen. The function of this screen is to determine the direction of movement for a positive (+) adjustment. In this application, a positive move indication means to ADD weight, sweep a blade FWD, move the blade UP with Pitch Change Link (BLADE) and move the blade DOWN with Trim Tab (TAB). Enter the values as shown below. When completed press [ENTER]. Next, the balance charts will be entered into the analyzer.

Model 4040 VIPER Analyzer				
M/R Adj Symbol & Soln Logic				
<u>Adjustment Positive Value Meaning</u>				
Weight:	ADD			
Sweep:	FWD			
Blade:	UP			
TAB:	DOWN			
Soln:	MAX			

10. The first balance chart to define will be the “Vert: 100KTS-MCP/30” chart. Enter the information as presented below. Press [ENTER] to continue.

Model 4040 VIPER Analyzer				
Main Rotor Chart Setup				
Name:	Vert 100KTS-MCP/30			
Type:	Regular	Sweep Only:	No	
No Adjustment Bld/Pos:	None			
Max ICF Update:	150	% R(°):	45	
Adj Unit:	DEG	Adj/IPS:	12.000	
Bld/Pos	MoveLine	Bld/Pos		
BLACK	7	:	20	
BLUE	4	:	20	
YELLOW				
RED				
Bld/Pos: in CW or CCW order				
+Adj = WtAdd/SwFwd/BldUp/TabDn				
Help				

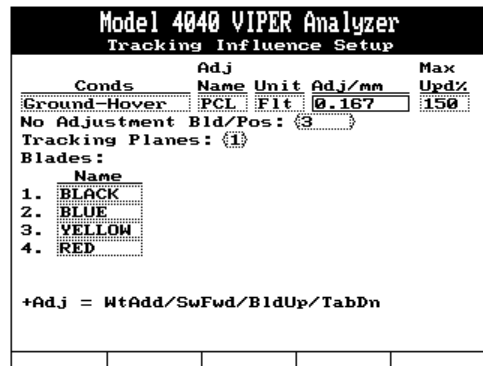
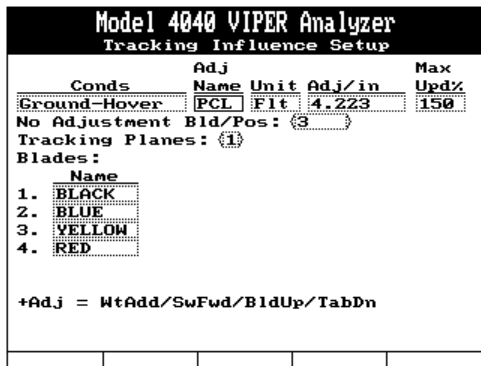
11. The second chart to define will be the “Lat: Ground-Hover” chart. Enter the information as shown below and press [ENTER] to continue.



12. Finally, the “Tracking Influence Setup” screen data will be entered as shown below. When completed, press [ENTER] to continue. Even though the analyzer rounds the “Adj/xx” value it will store the original value and use that entry for all adjustments.

English

Metric



D. Data Acquisition

- The “Job Identification” screen will be displayed, as shown below. Use the analyzer keypad to enter a customer name in the “Name:” field. The analyzer will maintain a list of customer names as new names are entered. If names have been previously entered into this analyzer, you may press the [F1] “Names” key and select a customer’s name from the provided list. Press the [↓] key to move to the next field and use the analyzer keypad to enter the optional aircraft registration and aircraft total time as required. When all fields are complete, press the [ENTER] key to accept and continue.

Model 4040 VIPER Analyzer				
Job Identification				
Name: CUSTOMER NAME				
A/C Registration: N1234				
A/C Total Time: 123.4				
Press ENTER to continue				
Names				

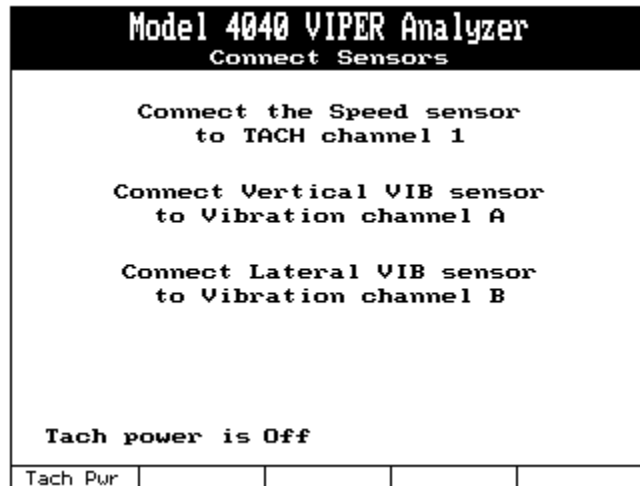
- The next screen to be displayed is the “Tracking Selections”, as shown below. Complete the first two fields as shown below. Then, rotate the Main Rotor head so that the Magnetic Pickup and Interrupter align (Figure 2). Measure the distance from the location where the Optical Tracker will be held to the tip of the “BLACK” blade. Enter the distance, in inches, into the “Inches To Blade Tip” field. When all fields are complete, press the [ENTER] key to continue.

NOTE

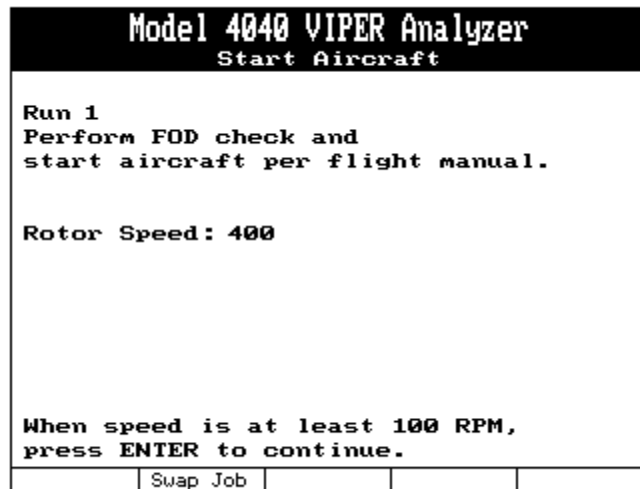
The entry on this screen for “Inches To Blade Tip” will ALWAYS be entered in inches. This field does not change when the measurement units change.

Model 4040 VIPER Analyzer				
Tracking Selections				
Track Device: Tracker				
- For Optical Tracking Only -				
Number of Rotations: 50				
Inches To Blade Tip: 130				

- The next screen to be displayed will be the “Connect Sensors” screen as illustrated below. This screen gives instructions on installing sensors and cables. The Tach will be automatically energized when this screen is exited. The [F1] “Tach Pwr” key supplies power to the optical tachometer for checking alignment with the reflective tape and is not used with the Mag Pick-Up.



4. The “Start Aircraft” screen will be displayed with instructions to “Perform FOD check and start aircraft per flight manual”. When the aircraft is started and normal operating conditions have been established, press the [ENTER] key to continue. Use the [F2] “Swap Job” key to return directly to the Main Menu without rebooting the analyzer.



5. The analyzer will display the “Select Aircraft Condition” screen as displayed below. Select the condition that you want to gather data for using the [↑] [↓] arrows and press [ENTER]. Pressing [F5] “Chk Track” will allow you to view the track picture but will not save the reading as part of the highlighted condition. See [Paragraph 7 below](#) to record the track picture with the condition’s vibration readings.

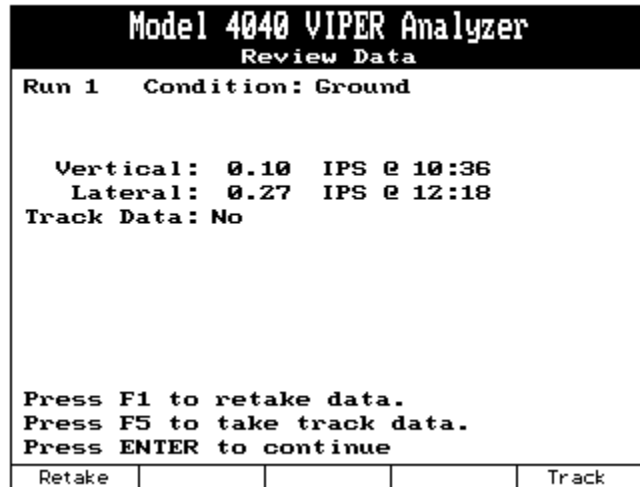
Model 4040 VIPER Analyzer				
Select Condition				
[]	Ground			
[]	Hover			
[]	100KTS			
[]	MCP			
[]	MCP/30			
End Run				Chk Track

6. The analyzer will present the data acquisition screen as shown below. This screen allows you to monitor both the current and averaged vibration readings. Operate the aircraft in the configuration for the selected condition and allow the analyzer to collect data. While monitoring the measurement, you may press the [F1] “Reset” key to restart the averaging process. Use this feature as a way to validate the quality of the measurement. If the averaged readings return to a value similar to the displayed value prior to being “Reset”, the measurement can be considered good. If the measurement is not similar, you may choose to “Reset” the average again. If the “Error” at the bottom of the text portion of the screen is not “0”, this is not an indication of failure or fault, only that the vibration averaging errors cannot be resolved below the displayed level. This “Error” value will typically be higher as the balancing process reduces the vibration amplitude. The “Error” indication should be as steady as possible with very little change before you press the [ENTER] key to stop acquisition.

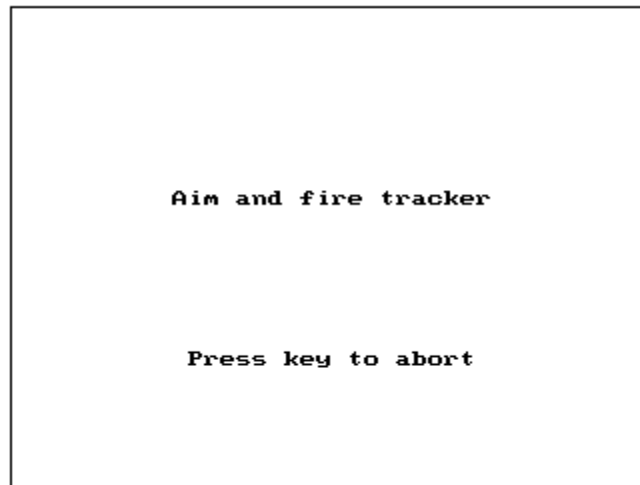
Model 4040 VIPER Analyzer				
Run:1 Condition:Ground				
1	2			
Current		1	2	
	RPM	400	400	
	Vib	0.17	0.53	
	Phase	9:27	4:33	
Average				
	RPM	400	400	
	Vib	0.10	0.27	
	Phase	10:36	12:18	
	Error	0.05	0.05	
1: Vertical		2: Lateral		
Reset				

See the Model 4040 User Manual #4040-OM-01 (P/N 75-900-4040) Chapter 20 for detailed instructions on how to read the “Converging Vibration Indicator and Scale”.

7. The “Review Data” screen will be displayed as shown in the example below. These are the amplitude and clock angle readings for the condition. You may retake the data by pressing the [F1] “Retake” function key as indicated at the bottom of the screen. When satisfied with the acquired data as displayed, press the [ENTER] key to accept the data with “No” track information and continue. To record the track picture for the condition, press [F5] “Track” and proceed to [Paragraph 8](#) below.

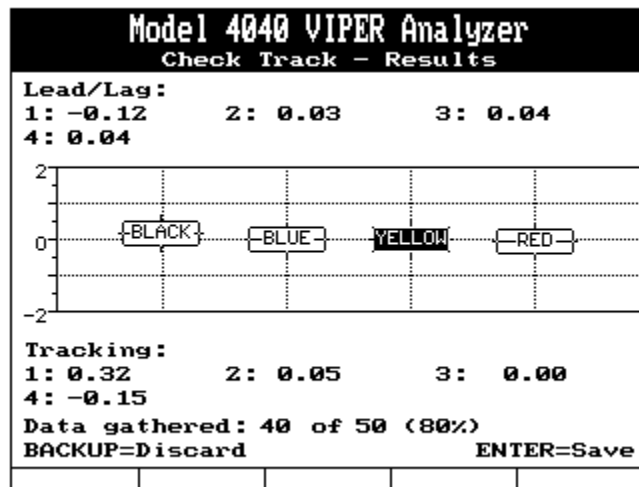


8. The “Aim and fire tracker” screen will be displayed as shown in the example below. Aim the tracker at the point in space that will lead the “BLACK” blade when the Magnetic Pickup and interrupter are aligned. (See Section B [Figure 2](#) above) Raise the tracker smoothly towards the rotating rotor disk while observing the LEDs on the back of the tracker.



- 8.1 Raise the tracker until the three green LED lights are illuminated.
- 8.2 Raise the tracker further to verify the upper set of three red LEDs illuminate. Illumination of the three upper LEDs verifies there is enough contrast to operate the tracker. If the upper set of red LEDs does not illuminate, there is not enough contrast for the tracker to operate properly.

- 8.3 If sufficient contrast is verified, slowly lower the tracker to a point where the center green LED is illuminated. Hold the tracker steady in this position.
- 8.4 To activate the tracker, press and release the trigger one time. It is not necessary to hold the trigger down. Continue to hold the tracker steady (green lights illuminated) while acquiring data. The amber light will pulsate during data acquisition.
- 8.5 When the amber light extinguishes, data acquisition is complete and you may lower the tracker.
9. The track picture will be displayed on the “Check Track – Results” screen. Lead/lag readings will be displayed at the top of the screen. A negative number (-) indicates a “Lead” condition as this blade is the indicated measurement less than the average interval. A positive number (no sign) indicates a “Lag” condition as this blade is the indicated measurement more than the average interval. Readings will be displayed graphically in the center of the screen. Lead readings will be indicated to the Left of the average interval marking vertical line. Lag readings will be displayed to the Right of the line. Track readings will be displayed above or below the line relative to the average of all blades or in relation to the blade specified in the setup, [Paragraph C.6 above](#). The bottom of the screen will give a numeric reading of the blade track elevation. The bottom line will display the number of data samples gathered. If the total number of data samples gathered is less than 75% of the total number of samples requested the results are questionable and should be retaken. When you are happy with the quality of the data, press [ENTER] to continue.



10. The “Review Data” screen will reappear as shown in the example below. This time the “Track Data” line will read “Yes” indicating that track data has been taken and stored in this condition. You may retake vibration data by pressing the [F1] “Retake” function key as indicated at the bottom of the screen. You may retake the track data by pressing the [F5] “Track” key. If you are satisfied with the current measurements, press [ENTER] to continue.

Model 4040 VIPER Analyzer				
Review Data				
Run 1 Condition: Ground				
Vertical: 0.10 IPS @ 10:36				
Lateral: 0.27 IPS @ 12:18				
Track Data: Yes				
Press F1 to retake data.				
Press F5 to take track data.				
Press ENTER to continue				
Retake				Track

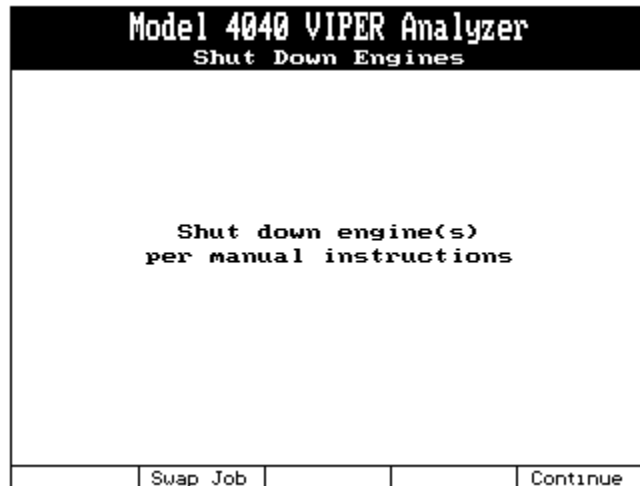
11. The “Select Aircraft Condition” screen will reappear as shown in the example below. This time any condition that has stored vibration and/or track data will have an [x] preceding the condition name. Repeat sequence through all flight regimes. You can choose to “End Run” at any time by pressing the [F1] “End Run” key. This sequence will allow you to review all previous measurements before proceeding to the suggested solutions. If a condition has recorded a vibration or track reading that is in excess of the limits defined in [Paragraph C.8 above](#), the word “Adjust” will appear above the [F2] key. Pressing [F2] “Adjust” will bypass the review process and move directly to the suggested solution screens. In either case you will be taken to [Paragraph 12 below](#).

Model 4040 VIPER Analyzer				
Select Condition				
[x]	Ground			
[x]	Hover			
[x]	100KTS			
[x]	MCP			
[x]	MCP/30			
End Run	Adjust			Chk Track

NOTE

The [F1] “End Run” and [F2] “Adjust” keys are the only ways to exit this screen. Pressing [ENTER] will restart the data collection process for the highlighted condition.

12. The analyzer will display the “Shut Down Aircraft” screen as shown below. Use the [F2] “Swap Job” key to return directly to the Main Menu without rebooting the analyzer. When the engine shut down process is complete, press the [F5] “Continue” key to review the data or view the suggested solutions.

**NOTE**

It is important to remember that when installing or removing weights and recording their positions the influence used for the next run will be updated by the result from the previous run's solution. Therefore, be as accurate as possible when recording adjustments made regardless whether the recommended solution is implemented. The only entries on these screens should reflect the actual solution implemented.

- The analyzer will present all of the solutions possible from the data gathered. It is possible for the analyzer to give two adjustments that would adversely affect the other. The user is ultimately responsible for determining which adjustments to implement and which to discard. If a suggested correction is determined unnecessary, use "Inst=None" [F2] to eliminate data in the "Installed" column. Make the desired adjustments to the rotor system as called for by analyzer and press [ENTER]. The user will now be prompted to start the engine and continue with Run #2.

E. Solution Examples

This section contains samples of the solution screens possibly encountered during the job. The corrections are examples only and do not reflect actual aircraft data. The actual solution screens encountered by the user will vary depending upon data acquired. Regardless of the measurement units selected, the adjustment should be similar.

CAUTION

At no point should a correction be made that contradicts information in the maintenance manual.

The analyzer will attempt to resolve the vibration and/or track level to 0.00. This may require adjustments that are not practical to duplicate. The technician must determine the closest possible match to the suggestion.

NOTE

Solutions will only be presented for readings that exceed the limits set in [Paragraph C.8 above](#). It is necessary to add the closest measurable amount of correction and record the actual correction in the "Installed" column.

The Model 4040 analyzer can only update internal Influence Coefficients when one solution per run

is implemented. Even though multiple solution screens are presented, entering solutions from multiple screens on the same run will disable the Influence Coefficient Update during the job.

1. The first possible solution screen is the “Vert: 100KTS-MCP/30, DEG” solution. This screen will suggest Trim Tab adjustments based on the measured vertical vibration readings.

In the example below, it is suggested to adjust the “YELLOW” trim tab DOWN 4.70 degrees (DEG) and adjust the “RED” trim tab DOWN 1.00 DEG. The closest measurable adjustment was 5.00 DEG on the “YELLOW” blade and 1.00 DEG on the “RED” blade. These adjustments were made and entered into the analyzer. (No (-) sign is required because the defined TAB direction is DOWN. In this case the positive move is DOWN. See the reminder line at the bottom of the screen.)

Model 4040 VIPER Analyzer		
M/R Suggested/Installed Adjustments		
Run 1		
Name: Vert 100KTS-MCP/30, DEG		
Bld/Pos	Suggested	Installed
BLACK	0.00	0.00
BLUE	0.00	0.00
YELLOW	4.70	5.00
RED	1.00	1.00
+Adj = WtAdd/SwFwd/BldUp/TabDn		
Inst=Sugg	Inst=None	Quit Job

2. The second possible solution screen available is from the “Lat: Ground-Hover, PLT” chart. This screen suggests the corrections to make to improve Lateral vibration readings.

In the example below, the suggestion is to add 4.01 plates (PLT) to the “BLACK” weight location and to add 3.61 PLT to the “RED” weight location. The closest full plate match to the suggestion is to add 4.00 PLT to “BLACK” and 4.00 PLT to “RED”. This addition was made and entered into the analyzer.

Model 4040 VIPER Analyzer			
M/R Suggested/Installed Adjustments			
Run 1			
Name: Lat Ground-Hover, PLT			
Bld/Pos	Suggested	Installed	
BLACK	4.01	4.00	
BLUE	0.00	0.00	
YELLOW	0.00	0.00	
RED	3.61	4.00	
+Adj = WtAdd/SwFwd/BldUp/TabDn			
Inst=Sugg	Inst=None		Quit Job

- The final possible solution comes from the “Tracking Influence Setup” screen and is named “Trk: Ground-Hover, PCL, F”. This screen will suggest correction to the Pitch Change Link (PCL) in flats (FLT) to bring the track within limits.

In this case, adjusting the “BLACK” blade DOWN by 1.20 flats and adjusting the “RED” blade UP 0.40 FLT should correct the track split. The closest measurable adjustment is to adjust “BLACK” down (-)1.00 FLT and adjust “RED” up 0.50 FLT. To enter a negative (-) number press the [SPACE] key once. The adjustments are made on the aircraft and the corresponding entries made in the analyzer.

Model 4040 VIPER Analyzer			
M/R Suggested/Installed Adjustments			
Run 1			
Name: Trk Ground-Hover, PCL, F			
Bld/Pos	Suggested	Installed	
BLACK	-1.20	-1.00	
BLUE	0.00	0.00	
YELLOW	0.00	0.00	
RED	0.40	0.50	
+Adj = WtAdd/SwFwd/BldUp/TabDn			
Inst=Sugg	Inst=None		Quit Job

F. Quit Job

- Repeat [Steps D.4](#) through [D.13](#) above applying the solutions as necessary. If all measurements in all conditions are below the limits set in [Paragraph C.8](#) above, the message below will appear. Pressing the [BACKUP] key will allow you to return to review the measurements from all runs. Pressing the [ENTER] key will allow you to take additional

readings if you choose. Pressing [F5] “Quit Job” will mark the job as complete and take you to [Paragraph 2](#) below.

Model 4040 VIPER Analyzer				
M/R Track & Balance				
No solutions are recommended.				
Press BACKUP to view data. Press F5 to quit job. Press ENTER for next Run.				
				Quit Job

- From the screen shown below, decide if you would like to update the ICF used in the original setup. Pressing [F1] “Yes” will add the chart corrections from this job to the ICF from the original setup. This can be a powerful tool when using this setup in the future. The chart corrections learned as a result of the previous job will be applied from the beginning of the next job that uses the same setup. This can reduce the number of runs required to balance the helicopter. If you select [F5] “No” any chart corrections applied during the previous job will be discarded. The setup will revert to the chart settings in place before the job was started. This can be useful if the helicopter didn’t respond as others of the same model or if a mistake was made somewhere during the job that caused extra runs to balance the helicopter.

Model 4040 VIPER Analyzer				
Update Setup ICFs?				
Do you want to update the setup's influence coefficients based on the result of this job?				
Yes				No