



Application Note

Enstrom Helicopters F28, 280, 480

Tail Rotor Balance

Part Number: 11-200-0191

AppNote Number: A-ENF28-280-480-4040-TR (Rev. 0, Jan 2005)

This Application Note is provided for information only and does not supersede the requirements or guidelines set forth in the applicable engine or airframe maintenance manual. Technology for Energy Corporation assumes no obligation or liability, either expressed or implied, to the Purchaser arising out of the use of this procedure.

Copyright © 2005, TEC Aviation Division. All rights reserved. This document is to be printed and reproduced for personal use only.



Application Note

A-ENF28-280-480-4040-TR

Revision	0 (From Airframe data Rev 2)
Function	Tail Rotor Balance
Airframe	Enstrom Helicopters All Models
Engine	N/A
E-Setup Number	a-enf28-280-480-4040-tr.asf
ACES Systems Analyzer	Model 4040 Viper
Firmware Version	1.0 or greater
Procedure	N/A

Introduction

This Application Note covers the required equipment, equipment installation, analyzer setup, data acquisition and solution process for using the ACES Systems Model 4040 with the Main and Tail Rotor Performance Option to perform a tail rotor balance on the airframe listed above. General instructions for the use of the Model 4040 can be found in the Model 4040 User Manual #4040OM-01 (P/N 75-900-4040). All procedures for track and balance and all adjustments should be made in accordance with the applicable Maintenance Manual.

A. Required Equipment

The following equipment is found in a standard 4040 Helicopter kit:

Item	Quantity	Description	Part Number
1.	1	Analyzer, Model 4040	10-100-4040
2.	1	Option, 4040 Main & Tail Rotor	11-900-0005
3.	1	Tachometer, Optical, Phototach (New)	10-100-1773*
4.	1	Cable, Tach, Generic, 50'	10-320-0126*
5.	1	Sensor, Vibe, Accel, 991D-1	69-100-0075
6.	1	Cable, Sensor 991D-1, 50'	10-320-0163
7.	1	Tape, Reflective, Roll, 10'	10-400-0176
8.	1	Mount, Triaxial Sensor 1/4"	22-430-0109
9.	1	Mount, Phototach, General Purpose	22-430-0066

*This listing shows the latest design parts. It is acceptable to perform this task using previous designs with the appropriate accessories. For compatibility issues, contact ACES Systems.

Miscellaneous Equipment

Tape or tie wraps to secure cables to airframe.

B. Equipment Installation

1. Position the helicopter on a flat surface with the nose facing into the wind.
2. Install Triaxial Sensor Mount, Item 8, on the ¼” bolt mounting the Tail Rotor Guard to the Tail Rotor Gearbox. (See Figure 1)
3. Insert Vibration Sensor, Item 5, mounting stud through ¼” hole in PhotoTach Mount, Item 9. (See Figure 1)
4. Thread Vibration Sensor into bottom hole of Triaxial Sensor Mount. Clamp PhotoTach Mount between Vibration Sensor and Triaxial Sensor Mount. Locate ¾” hole in PhotoTach Mount to the Left of the Triaxial Sensor Mount as viewed from the Right side of the Aircraft. Insure connector of Vibration Sensor faces down. (See Figure 1)

WARNING

When routing cables, use caution to avoid rotating components, engine exhaust system, or aircraft controls.

5. Connect Cable, Item 6 to Vibration Sensor and secure along tailboom. Route cable into cockpit of aircraft.
6. Install PhotoTach, Item 3 into PhotoTach Mount facing tail rotor assembly. Secure with nylon nut or sunshield. (See Figure 1)
7. Connect cable, Item 4, to PhotoTach and secure along tailboom. Route cable into cockpit of aircraft.
8. Attach Phototach cable to Tach 1 of the ACES Model 4040 Analyzer. Attach the vibration sensor cable to Channel A of the ACES Model 4040 Analyzer.
9. See paragraph D.3 below for additional instructions for placing reflective tape. (See also Figure 1 and Figure 2)

Equipment Installation Diagram

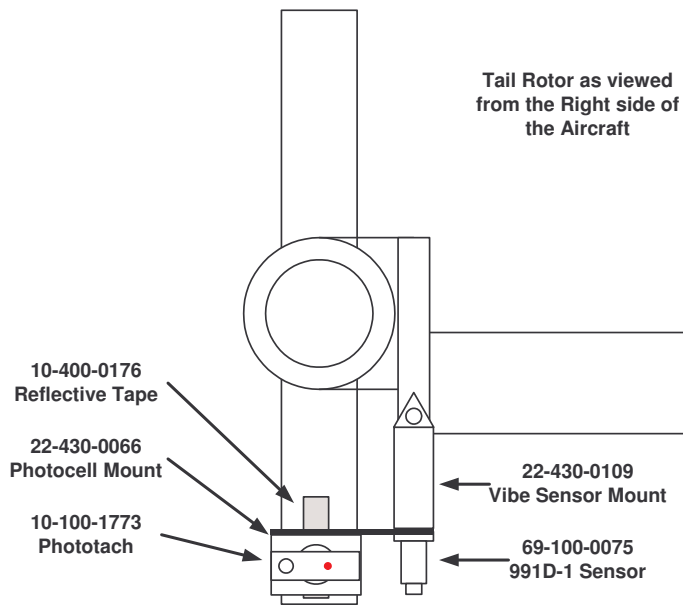

Figure 1

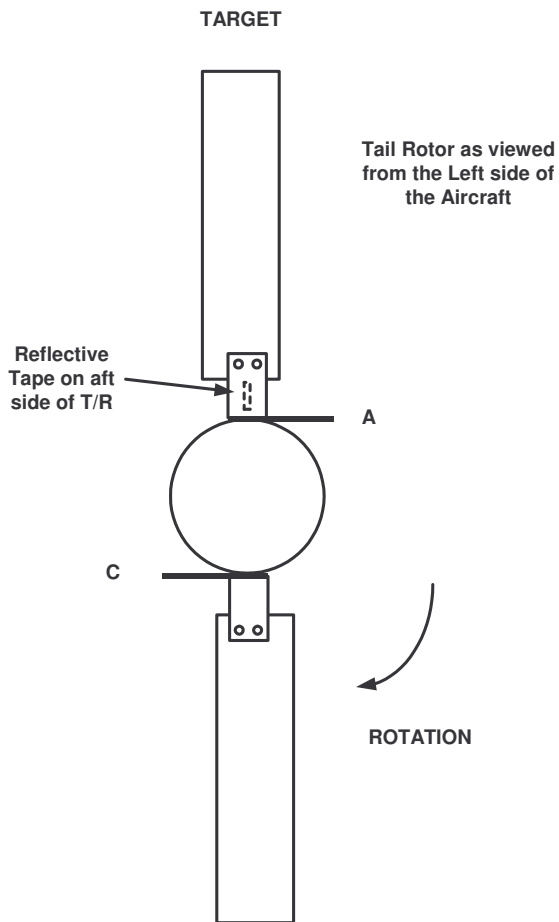

Figure 2

C. Analyzer Set Up

1. Turn the analyzer [ON].
2. Enter a new setup as follows; from the “Main Menu” select “Tail Rotor Balance” and press [ENTER]. From the “Tail Rotor Balance” menu, select “Manage Setups” and press [ENTER]. From the “Manage Setups” menu, select “New” and press [ENTER].
3. The “Tail Rotor Setup” screen now appears. Enter the tail rotor setup as shown. When completed press [ENTER].

```

Model 4040 VIPER Analyzer
Tail Rotor Setup
Name: ENSTROM
Sensor Chan: A
Sensor: 991D-1

Tach Chan: 1
Tach Type: Optical
Tach Pos: 6

Balancing RPM: 2500
Rotor Direction: CW
Number of Blades: 2
Conditions: 1
Max Baln. Wts: 15.0
  
```

4. The “Tail Rotor Chart Setup” screen will define the chart to be used when calculating corrections for a given measurement. The weight positions are entered in passing order as shown below. Enter the information exactly as it appears in the appropriate fields. When completed, press [ENTER].

```

Model 4040 VIPER Analyzer
Tail Rotor Chart Setup
Name: ENSTROM
Chart Type: Irregular Num WtPos: 4
WtPos Grams IPS Add @
TARGET 0.60 1.00 11 : 15
C 8.00 1.00 3 : 30
B 0.60 1.00 5 : 15
A 8.00 1.00 9 : 30

WtPos MUST be in CW or CCW order
  
```

5. The setup is now complete, press [BACKUP], select “Start Job”, press [ENTER] and then select the “Tail Rotor Setup” that was just created.

D. Data Acquisition

1. “Job Identification” screen. To assist with the identification of the job when it is printed and/or stored in the analyzer, it is recommended that this screen be completed. When finished press [ENTER].

Model 4040 VIPER Analyzer				
Job Identification				
Name : CUSTOMER NAME				
A/C Registration: N1234				
A/C Total Time: 123.4				
Press ENTER to continue				
Names				

2. “Tail Rotor Equipment Setup”. Information screen that prompts the user to verify equipment installation has been performed in accordance with channel selections that were specified when building the setup.

Model 4040 VIPER Analyzer				
Tail Rotor Equipment Setup				
Install the speed sensor and connect to tach channel 1				
Install vibration sensor and connect to vib. channel A				
Tach power is Off				
Tach On				

3. Install and align reflective tape with PhotoTach as follows:
 - a. Press [F1] “Tach On”. Align one blade with the phototach. (See Section B Figure 2)
 - b. Hold a 2-inch piece of reflective tape, reflective surface facing the Phototach, against the backside of the blade or grip. Do not remove backing at this point.
 - c. The red “Gate” light on the back of the Phototach should illuminate as the reflective tape is properly aligned in front of the LED. Clean an area of the blade or grip in preparation for mounting the reflective tape.

- d. Remove the backing and install the reflective tape on the clean blade or grip surface.
 - e. When tape installation is complete, press **[ENTER]** to continue.
4. “Start Aircraft” screen. This screen allows the user to view the current tail rotor RPM. When the aircraft has been started press **[ENTER]**.

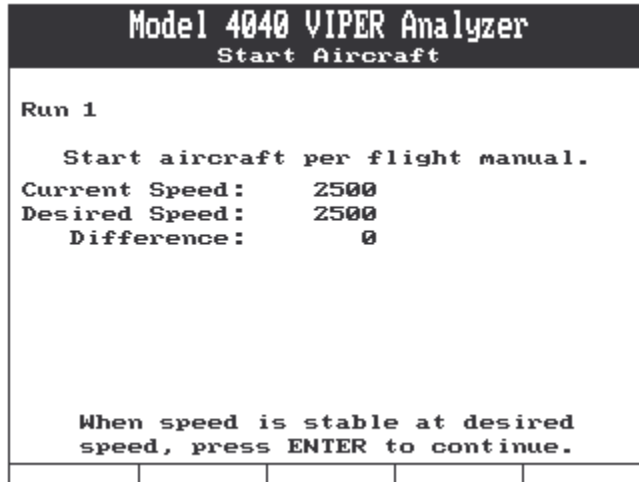

5. The analyzer will present the data acquisition screen as shown below. This screen allows you to monitor both the current and averaged vibration readings. While monitoring the measurement, you may press the **[F1]** “Reset” key to restart the averaging process. Use this feature as a way to validate the quality of the measurement. If the averaged readings return to a value similar to that prior to being “Reset”, the measurement can be considered good. If the measurement is not similar, you may choose to “Reset” the average again.

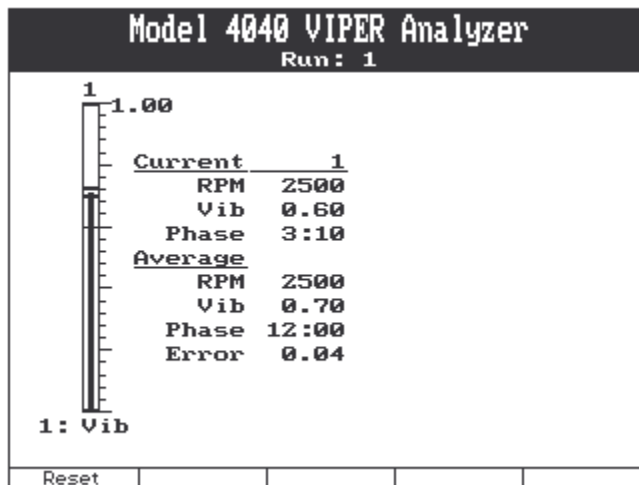

See the Model 4040 User Manual #4040OM-01 (P/N 75-900-4040) Chapter 20 for detailed instructions on how to read the “Converging Vibration Indicator and Scale.”

6. You will be prompted to “Shut Down Aircraft”. Press **[F5]** to proceed. The “Review Prior Run(s) Data” screen will appear. This screen allows the user to view the vibration readings that were acquired during the condition. Press **[F1]** to “Retake” the data or **[ENTER]** to continue. Pressing **[F5]** will “Quit Job”.

Model 4040 VIPER Analyzer				
Review Prior Run(s) Data				
Run	RPM	IPS	Clock	
1	2500	0.700	12:00	
Retake #1				

- The “T/R Sugg. & Inst. Wts” screen will present a suggested solution based on the chart created in the original setup and the vibration IPS and clock reading. You have the opportunity to install the suggested weight corrections or decide on a different corrective action. It is important that the entry under the “Enter Installed Wts” reflect the actual weight amounts and locations used.

Using the keypad, record the actual weight(s) installed between runs and their location. If you choose to remove weight from an opposite or alternate position, enter the negative adjustment. Do this by moving the highlight to the appropriate field, press the [SPACE+/-] key to produce a (-).

Model 4040 VIPER Analyzer				
T/R Suggested/Installed Weights				
Run 1	Suggestion:			
Chart:	ENSTROM			
TARGET	0.5	C	2.4	
Enter Installed Weights:				
TARGET	0.0			
C	2.5			
B	0.0			
A	0.0			
Inst=Sugg	Inst=None			Quit Job

To remove all suggested values use the [F2] “Inst=None” key. If you decide you would like to revert back to the suggested weights use the [F1] “Inst=Sugg” key.

The [F5] “Quit Job” key exits the balance job with no provisions to resume the job at a later point in time. If you wish to leave the job and be able to resume it later, press the [MAIN MENU] key.

8. When you have finished with the solution process, press **[ENTER]** and you will be taken to the “Start Aircraft” screen as shown in paragraph 4 of this section to continue the balance process.