



# Application Note

---

## Embraer EMB-120

### Propeller Balance

**Part Number: 11-200-0233**

**AppNote Number: A-EMB120-4040-PB (Rev. 3.0, Nov 2008)**

This Application Note is provided for information only and does not supersede the requirements or guidelines set forth in the applicable engine or airframe maintenance manual. Technology for Energy Corporation assumes no obligation or liability, either expressed or implied, to the Purchaser arising out of the use of this procedure.

Copyright © 2008, TEC Aviation Division. All rights reserved. This document is to be printed and reproduced for personal use only.



# Application Note

Application Note Number	A-EMB120-4040-PB
Revision	3.0 (From Airframe Rev June 1991)
Function	Propeller Balance
Airframe	Embraer EMB-120
Engine	N/A
E-Setup Number	a-emb120-4040-pb.asf
ACES Systems Analyzer	Model 4040
Firmware Version	3.xx or later
Procedure	N/A

## Introduction

This Application Note covers the required equipment, equipment installation, analyzer setup, data acquisition and solution process for using the ACES Systems Model 4040 with the Propeller Balance Performance Option to perform a Propeller balance on the Embraer EMB-120. General instructions for the use of the Model 4040 can be found in the Model 4040 User Manual #4040-OM-01 (P/N 75-900-4040). All procedures for Propeller Balance and all adjustments should be made in accordance with the Aircraft Maintenance Manual.

## A. Required Equipment

The following ACES Systems equipment is required\*:

Item	Quantity	Description	Part Number
1.	1	Analyzer, Model 4040	10-100-4040
2.	2	Sensor, Vibe, Accel, 991D-1	69-100-0075
3.	1	Scale, Gram, Pocket Pro	75-900-0505
4.	1	Placards, ACES Prop Balance	Z82-100-0117
5.	1	Manual, ACES Guide to Prop Balancing	10-300-0048
6.	1	Protractor, Propeller	82-100-0032
7.	2	Cable, Interface, EMB120 to 991D-1	10-320-0295
8.	1	Cable, Interface, EMB120 to Analyzer for 991D-1	10-320-0296
9.	1	Option, 4040 Propeller Balance	11-900-0007

\*This listing shows the latest design parts. It is acceptable to perform this task using previous designs with the appropriate accessories. For compatibility issues, contact ACES Systems.

### Optional Equipment

The following equipment may be used as an alternate

Item	Quantity	Description	Part Number
10.	2	Sensor, Vibration, Velocity, 991V	69-100-0064
11.	2	Cable Interface, EMB120 to 991V	10-320-0227
12.	1	Cable, Interface, EMB120 to Analyzer for 991V	10-320-0228

### Miscellaneous Equipment

Vibration Sensor Mount – Embraer Part, see Figure 1.

Tape or tie wraps to secure cables to airframe.

## B. Equipment Installation

1. Place analyzer (Item 1) in flight compartment.
2. Obtain access to the engine compartment. (Figure 1)

#### NOTE

**Secure and route cables as not to interfere with hot or rotating components.**

3. Install the 991D-1 Vibe Sensor (Item 2) (Optional – insert the 991V Vibration Sensor (Item 10)) into the Vibe Sensor Mount. The vibration sensor should be installed with the electrical connector pointing up toward the 11 o'clock position.
4. Connect a Sensor Interface Cable (Item 7 for 991D-1 or Item 11 for 991V) to the Sensor and the bulkhead fitting on the engine.
5. Connect the Airframe Interface Cable (Item 8 for 991D-1 or Item 12 for 991V) to the “J1842” synchrophazer connector inside the cabin. (Figure 2) Connect the “TACH L ENGINE” connector to TACH 1 on the analyzer. Connect the “VIBE L ENGINE” connector to CHANNEL A on the analyzer. Connect the “TACH R ENGINE” connector to TACH 2 on the analyzer. Connect the “VIBE R ENGINE” connector to CHANNEL B on the analyzer.
6. When using the Model 4040 Viper, all weight additions will reference the hole number as shown in Figure 3. DO NOT DRILL additional holes in the propeller bulkhead but rather use the holes available when adding weights.
7. Reinstall any previously removed engine cowlings.

Equipment Installation Diagram

Figure 1

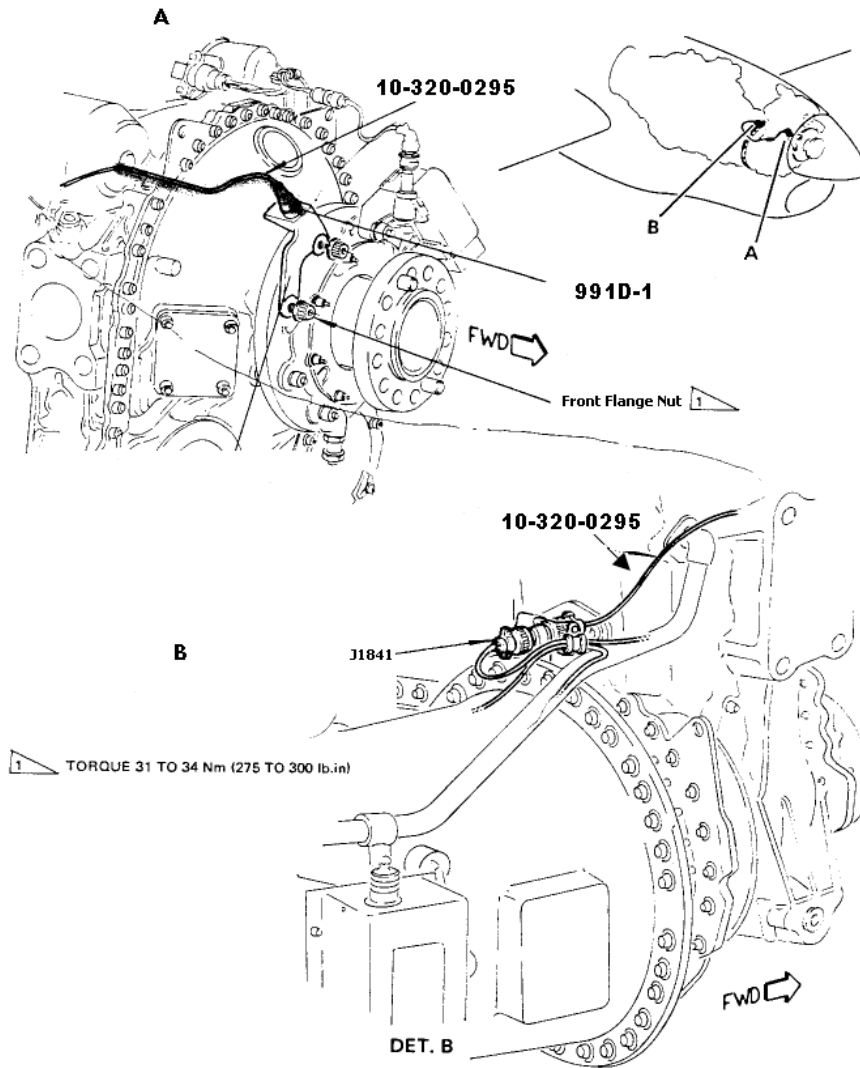

Figure 2

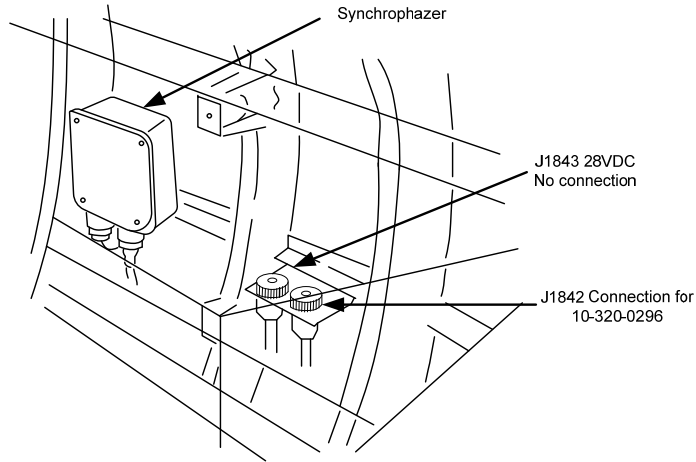
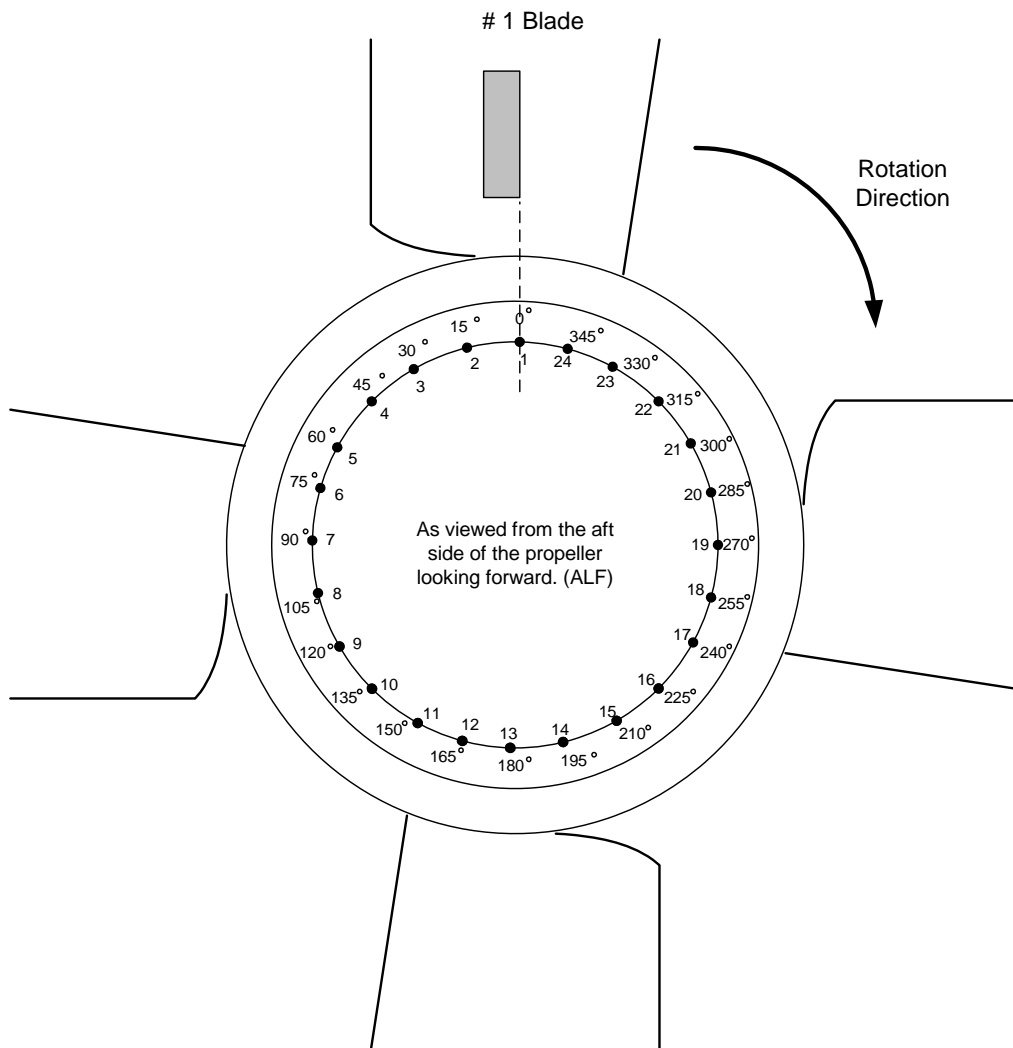

Figure 3



## C. Analyzer Set Up

1. Insure the analyzer battery is charged prior to starting the job. See the Model 4040 User Manual #4040-OM-01 (P/N 75-900-4040) Chapter 2 for detailed instructions on battery charging.
2. Turn the analyzer ON by pressing the [ON/OFF] key.
3. From the Main Menu, select “Propeller Balance” and press the [ENTER] key.
4. From the Propeller Balance Menu, select “Start Job” and press the [ENTER] key.
5. If the Embraer EMB-120 is listed in the Setup List, select it using the [↓] key, press [ENTER] and go to Section D Paragraph 1 below. If the Embraer EMB-120 is not in the Setup List, press the [F1], “New” key and go to step 6 below.
6. Complete a Prop Balance Setup screen per the illustration screen below. This setup can be used for both engines or separate setups can be created for the Left and Right engines individually. By creating individual setups, the ICF for each engine can be stored for future use.

Model 4040 VIPER Analyzer			
Prop Balance Setup			
Name:	a-emb120#1-4040-pb		
Eng HP:	1800		
Max Wts:	620	Balance RPM:	1105
Relative to:	Sensor	Holes:	Yes
Vib:	IPS	Peak	FSR: 1.00
Rotation (#1):	CCW		
Tach Type:	Mag(Lo)		
Tach Chan:	1		
Tach Pos (FLA):	12:00		
Sens Type:	991D-1		
Sens Chan:	A		
Sens Pos (FLA):	11:00		
Edit ICF			Sensor

- 6.1. In the “Name:” field, use the analyzer keypad to enter “Embraer EMB-120”. Make sure to identify setups for the #1 and #2 engines as necessary. Press the [↓] key to move to the next field.
- 6.2. In the “Eng HP:” (Engine Horsepower) field, use the analyzer keypad to enter “500”. Press the [↓] key to move to the next field.
- 6.3. In the “Balancing RPM:” use the analyzer keypad to enter “1150”. Press the [↓] key to move to the next field.
- 6.4. In the “Max Baln. Wts:” field; use the analyzer keypad to enter “650”. This is the maximum total amount of balance weights that may be added to the propeller assembly to accomplish the job. You will enter a maximum amount per hole in another screen. Press the [↓] key to move to the next field.

- 6.5. In the “Holes:” field, press the [⇒] key until the field reads “Yes” to indicate there are pre existing holes where balance weights are added that must be defined. Press the [↓] key to move to the next field.
- 6.6. In the “Wts relative to:” field, press the [⇒] key until the field reads “Sensor”. This indicates the angle to each of the holes is measured relative to the position of the vibration sensor on the propeller, which is used as an index point. Align the Tach interrupter and Tach then use the propeller protractor (Item 6) to measure from the location of the vibration sensor. Press the [↓] key to move to the next field.
- 6.7. In the “Rotation (#1):” field, press the [⇒] key until the field reads “CCW” for counterclockwise. Press the [↓] key to move to the next field.
- 6.8. In the “Tach Type:” field, press the [⇒] key until the field reads “Mag(Lo)” indicating you will use the optical Phototach. Press the [↓] key to move to the next field.
- 6.9. For the #1 engine in the “Tach Chan:” field, press the [⇒] key until the field reads “1” indicating that you will be using the “TACH 1” connector on the analyzer. In the #2 engine setup use the [⇒] key to select “2” to use the “TACH 2” connector on the analyzer. This way you can connect all cables for use during the same run. Press [↓] key to move to the next field.
- 6.10. In the “Tach Pos” (FLA): field, press the [⇒] key until the field reads “12:00”. This indicates the clock position where the PhotoTach is triggered by the passage of the reflective tape, as viewed from forward of the engine looking aft toward the tail of the aircraft. Press the [↓] key to move to the next field.
- 6.11. In the “Sens Type:” field, if the 991D-1 Sensor is installed, press the [⇒] key until the field reads “991D-1” as shown. If the 991V Sensor is installed, select “991V” from the list. Press the [↓] key to move to the next field.
- 6.12. For the #1 engine in the “Sens Chan:” field, press the [⇒] key until the field reads “A” indicating that you will be using the “CHANNEL A” connector on the analyzer. In the #2 engine setup use the [⇒] key to select “B” to use the “CHANNEL B” connector on the analyzer. This way you can connect all cables for use during the same run. Press [↓] key to move to the next field.
- 6.13. In the “Sens Pos: (FLA) field, press the [↓] key until the field reads “11:00”. This indicates the mounted axis relative to the prop shaft. Press the [ENTER] key to continue.
7. The “Prop Hole Layout Setup” screen will be displayed as illustrated in the screen below. The “Name:” field will automatically be filled in from the previous screen above. Press the [↓] key to move to the “No. of Holes:” field. Use the analyzer keypad to enter “24” in the field. Press the [↓] key to move to the next field.

```

Model 4040 VIPER Analyzer
Prop Hole Layout Setup
Name: a-emb120#1-4040-pb
No. of Holes: 24 Space: Even
Dir (FLA): CW Max H. Wt: 50
Angle of No.1 Hole: 315

```

- 7.1. In the “Space:” field, press the [⇒] key until the field reads “Even”. The screen will immediately change to display the hole layout grid shown above. Press the [↓] key to move to the next field
  - 7.2. In the “Dir (FLA):” field, press the right arrow key until the field reads “CW” for counterclockwise. This is the direction of the hole numbering sequence for the installation. This direction is independent of the method used to determine the location of hole #1 in step C below. Press the [↓] key to move to the next field.
  - 7.3. In the “Max H. Wt:” (Maximum Hole Weight) field, use the analyzer keypad to enter “50”. Press the [↓] key to move to the next field
  - 7.4. In the “Ang of First Hole” field, use the keypad to enter “315”. This indicates that hole #1 is located at 315 degrees, measured in a clockwise direction as viewed from the front, relative to the vibration sensor when the propeller is in a position with the Tach and Interrupter aligned. This measurement is independent of the direction of increasing hole numbers set in step 7.2 above. When complete, press the [ENTER] key to accept and continue.
8. Follow the instructions above to create an identical setup with a different name for the other engine.

## D. Data Acquisition

---

1. The “Job Identification” Screen will be displayed, as shown below. Use the analyzer keypad to enter a customer name in the “Name:” field. The analyzer will maintain a list of customer names as new names are entered. If names have been previously entered into this analyzer, you may press the [F1] “Names” key and select a customers name from the provided list. Press the [↓] key to move to the next field and use the analyzer keypad to enter the optional aircraft registration and aircraft total time as required. When all fields are complete, press the [ENTER] key to accept and continue.

Model 4040 VIPER Analyzer				
Job Identification				
Name: CUSTOMER NAME				
A/C Registration: N1234				
A/C Total Time: 123.4				
Press ENTER to continue				
Names				

- The next screen to be displayed is the “Engine Information” screen, as shown below. While all these fields are optional, we highly recommend you fill in as much information as possible to provide better record keeping and search functions in AvTrend. Use the key pad and the arrow keys to complete the fields for the engine. S/N = Serial Number. In the serial number field, you may press the [F1] “Serial Nos” key to select the serial number from a list if this number has previously been entered in this analyzer. Type = Type engine or prop. Pos = position (1 or 2). TSO = Time since overhaul and TSN = Time since new. All fields are filled in using the analyzer keypad except the Pos: field which is selected using the [⇒] key. When all fields are complete, press the [ENTER] key to continue.

Model 4040 VIPER Analyzer				
Engine Information				
Position: 1				
Propeller:				
S/N				
Type				
TSO 0				
TSN 0				
Engine:				
S/N				
Type				
TSO 0				
TSN 0				
Serial Nos				

- The next screen to be displayed will be the “Connect Sensors” screen as illustrated below. This screen gives instructions on installing sensors and cables. The screen below demonstrates the connections on the #1 engine. When balancing the #2 engine the TACH channel will be “2” and the Vibration channel will be “B”.

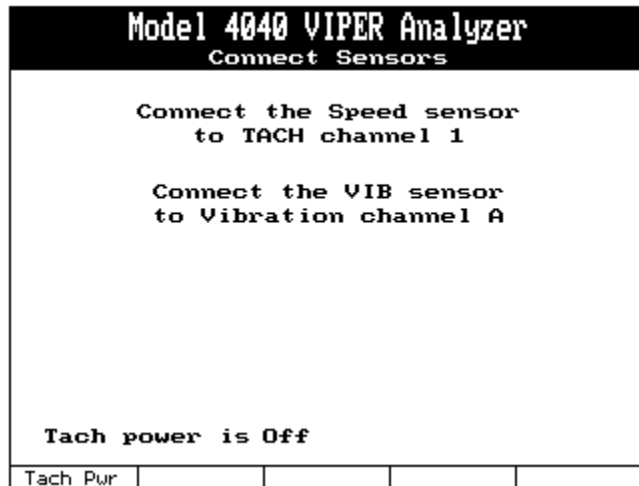

4. The “Start Aircraft” screen will be displayed with instruction to “Remove all trim weights. Perform FOD check and start engine(s) per flight manual”. Remove all previously installed trim balance weights from all hole locations to begin the balance with a clean spinner. When you have verified that all weights are removed, press the [ENTER] key to continue. You can use the [F2] “Swap Job” key to return directly to the Main Menu without rebooting the analyzer. This will be useful when switching from the #1 engine to the #2 then back.

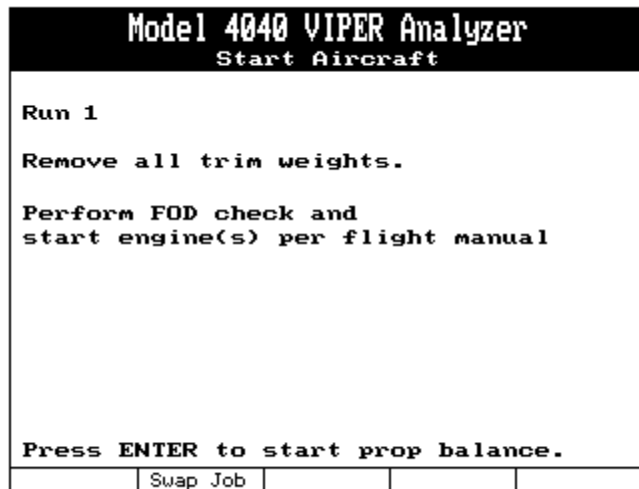

5. The analyzer will display the Engine 1, Run 1 screen similar to the one below. Chapter 20 of the Model 4040 User’s Manual gives detailed instructions on how to read the converging scale if you are not familiar with it. Increase RPM on the engine to a low cruise setting and allow the analyzer to collect data for approximately 10 to 15 seconds. The “Error:” indication at the bottom of the text portion of the screen should be as steady as possible with very little change before you press [ENTER] to stop acquisition. If the Error is not “0”, this is not an indication of failure or fault, only that the vibration averaging errors cannot be resolved below the displayed level. This Error value will typically be higher as the balancing process reduces the vibration amplitude.

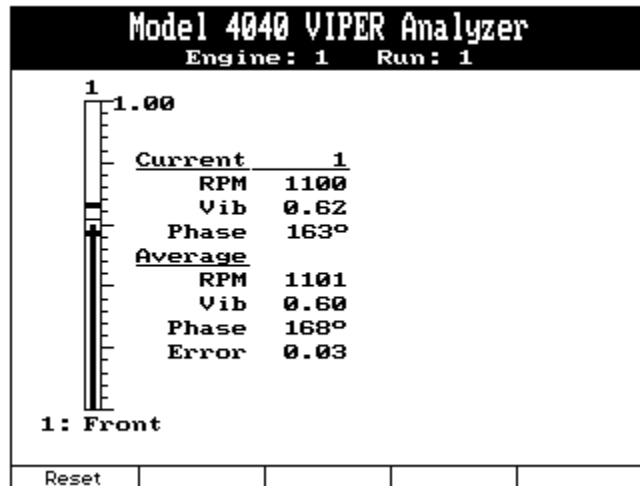

6. After pressing [ENTER] the “Review Job” screen will be displayed as shown in the example below. This is the amplitude and phase angle reading for the engine. You may retake the data by pressing the [F1] “Retake #1” function key as indicated at the bottom of the screen. When satisfied with the acquired data, press the [ENTER] key to accept and continue.

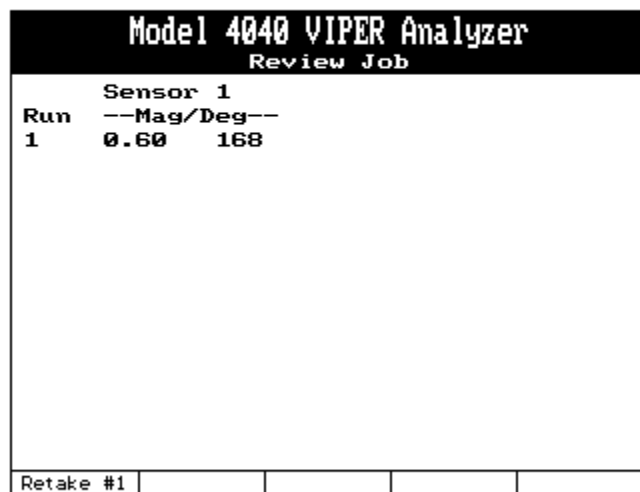

7. The “Shutdown Down Engines” instruction screen will be displayed as shown in the example below. You can use the [F2] “Swap Job” key to return directly to the Main Menu without rebooting the analyzer. At this point you can “swap” to the other engine’s “job” to take its vibration reading during the same run. Shut down the engine using normal shutdown procedures. When all shutdown tasks are complete, press the [F5] “Continue” key.

Model 4040 VIPER Analyzer			
Shut Down Engines			
Shut down engine(s) per manual instructions			
	Swap Job		Continue

8. The Prop Suggested and Installed Weights screen shown below will be displayed. At the top of the screen you will see the Run number. The left side of the screen shows the Suggested weight installation by actual weight and phase angle. Directly below the raw solution you will see a specific weight (in grams) in the left column and a corresponding hole number(s) in the right column where that weight should be installed. The Installed column at the right side of the screen is where you must enter the actual weight and hole number(s) where that weight was installed. Be as accurate as possible with the installed weight as the analyzer will use this information to calculate the follow on influence for the next solution (if required). Notice at the bottom of the screen the instructions: "Remove old, install & enter new weight." This means that ALL previously installed weights must be removed with each new weight installation. At the bottom of the screen, the three function keys are defined as: [F1], Inst=Sugg, press this key to default the Installed columns to the values displayed in the Suggested column. [F2], Inst=None, press this key to zero out all weight in the Installed column. [F5], Quit Job, press this key if you are satisfied with the current vibration levels and wish to terminate the balance job, leaving the previously installed weights in place. After the screen is complete per your actions, press the [ENTER] key to continue.

Model 4040 VIPER Analyzer			
Prop Suggested/Installed Weights			
Run 1			
Suggested		Installed	
14.6	@ 112 °	14.9	@ 112 °
grams	Hole	grams	Hole
7.9	8	8.0	8
6.9	9	7.0	9
0.0	1	0.0	1
0.0	1	0.0	1
0.0	1	0.0	1
0.0	1	0.0	1
Remove old weights; install and enter new weights. Press ENTER to continue			
Inst=Sugg	Inst=None		Quit Job

9. If you chose to continue the job, the screen below will be displayed indicating you are ready to start the engine for the next run. Steps 4 through 9 will be repeated until the vibration amplitude has been reduced to a satisfactory level, usually three runs total. You can use the [F2] “Swap Job” key to jump immediately to the Main Menu without rebooting the analyzer. This is a quick way to swap between left engine and right engine balance jobs.

Model 4040 VIPER Analyzer				
Start Aircraft				
Run 2				
Perform FOD check and start engine(s) per flight manual				
Press ENTER to start prop balance.				
	Swap Job			

## E. Quit Job

1. If you selected [F5] “Quit Job” from Section D Paragraph 9 above you will be presented with the following confirmation screen. If you are certain you want to end the job press [F1] “Yes” and the job will be marked as completed. Choosing [F2] “No” will take you back to the job in progress.

Model 4040 VIPER Analyzer				
Warning! You are about to terminate this balance job!				
Are you sure you want to quit?				
Yes				No

2. Selecting [F1] “Yes” from the screen shown in step 1 above will cause the following screen to be displayed. Press [F1] “Yes” if the job went as expected. It is possible to update and store the calculated ICF in the setup. This allows you to refine the ICF and potentially reduce

the number of runs required in future jobs using this same setup. Select [F2] “No” if the balance job did not go as expected. This will keep mistakes or poor mechanical condition from influencing the setup causing unnecessary runs when using the same setup in the future.

Model 4040 VIPER Analyzer				
Update Setup ICFs?				
Do you want to update the setup's influence coefficients based on the result of this job?				
Yes				No

3. Remove all test equipment and return aircraft to airworthy condition. Insure only permanent weights are mounted on the propeller and that they are mounted in accordance with the manufacturer's instructions or the *ACES Guide to Propeller Balance* as applicable.