



Application Note

Aircraft Type: Britten Norman BN-2T Islander

Procedure: Propeller Balance

Part Number: 11-200-0180

AppNote Number: A-BN-2T-2020-PB

This Application Note is provided for information only and does not supercede the requirements or guidelines set forth in the applicable engine or airframe maintenance manual. Technology for Energy Corporation assumes no obligation or liability, either express or implied, to the Purchaser arising out of the use of this procedure.

Copyright © 2002, TEC Aviation Division. All rights reserved. This document is to be printed and reproduced for personal use only.



Application Note

Application Note Number	A-BN-BN-2T-2020-PB
Revision	0
Function	Propeller Balance
Airframe	Britten Norman BN-2T Islander
Engine	Allison Model 250 B17-C& F
E-Setup Number	A-BN-BN-2T-2020-PB
ACES Systems Analyzer	2020 (Enhanced Propeller)
Firmware Version	2.06B
Procedure	N/A

Introduction

This Application Note is required to perform a propeller balance procedure on a Britten Norman BN-2T Islander airframe with a Rolls-Royce (Allison) 250-B17-C or F C engine. This Application Note describes the steps necessary to perform the physical set up of equipment (e.g., cabling, sensor mounting, etc.) and configuring the 2020 analyzer with the necessary setup information.

A. Required Equipment

The following ACES Systems' equipment is required.

Item	Quantity	Description	Part Number
1.	1EA	2020 PROBALANCER PROP KIT	N/A
2.	1EA	OPTION, 2020 ENHANCED PROPELLER	11-900-0001

Optional Equipment

None

Miscellaneous Equipment

Other items that may be required: duck tape or wire ties (for securing cables), scissors (for cutting the reflective tape), hand tools as necessary and assorted AN washers as described in the ACES Guide to Propeller Balancing (used as balance weights).

B. Equipment Installation

1. Make sure your ProBalancer is fully charged before you start the job. If it is not, connect the charger and allow the unit to charge while you complete the equipment installation.
2. Assemble the Phototach and Phototach Mount from the Propeller Balance Kit as necessary. (See the diagram, Figure 1. below).
3. Remove two ¼ inch nuts from the reduction gearbox case split line located at the nine o'clock position as viewed from forward of the engine looking aft. Install the Phototach and vibration sensors mount on the split case studs and reinstall the nuts. Install the Phototach on the sensor mount with the lens of the Phototach pointing forward toward the propeller assembly. Install the vibration sensor to the sensor mount with the connector end pointing vertically up. (See the photograph in Figure 3. below).
4. Connect the socket end of the generic tachometer cable, PN 10-32-0153, to the Phototach connector. Connect the 3-pin end of the vibration cable, PN 10-320-0162, to the 991D-1 vibration sensor. Route these cables back to the cockpit avoiding hot areas and moving components. Secure the cables every 36 inches to prevent movement or ingestion into the engine or propeller. Connect the generic tachometer cable, PN 10-320-0153 to the TACH 1 input of the 2020 ProBalancer. Connect the six-pin connector of the vibration cable, PN 10-320-0162 to the CHAN A input of the 2020 ProBalancer.
5. Locate #1 blade of the propeller assembly. Draw an imaginary line radially from the outer edge of the spinner bulkhead to the center of the propeller drive shaft, centered on the #1 propeller blade. (See Figure 2. Below). At a position directly in line with the beam of the Phototach, clean the bulkhead of any dirt, grease, or oil residue. Cut a two inch length of the reflective tape from the prop balance kit and remove the backing. Stick the tape to the bulkhead area you just cleaned with the leading edge of the tape along the leading edge of the imaginary line with the center of the tape length at the approximate point where the Phototach beam will be projected. (See Figure 2. below).

Equipment Installation Diagram

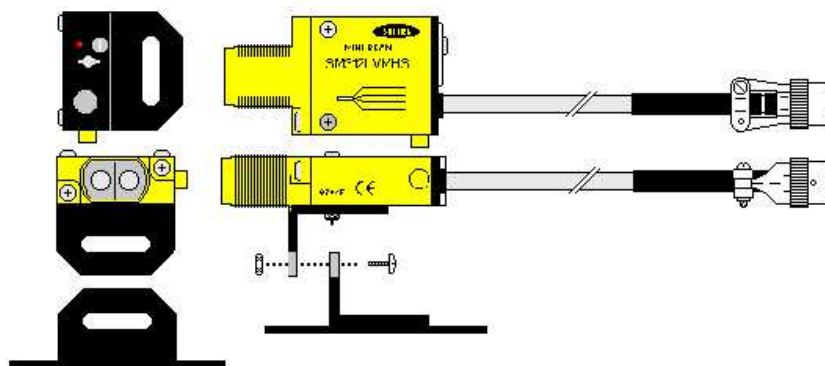

Figure 1

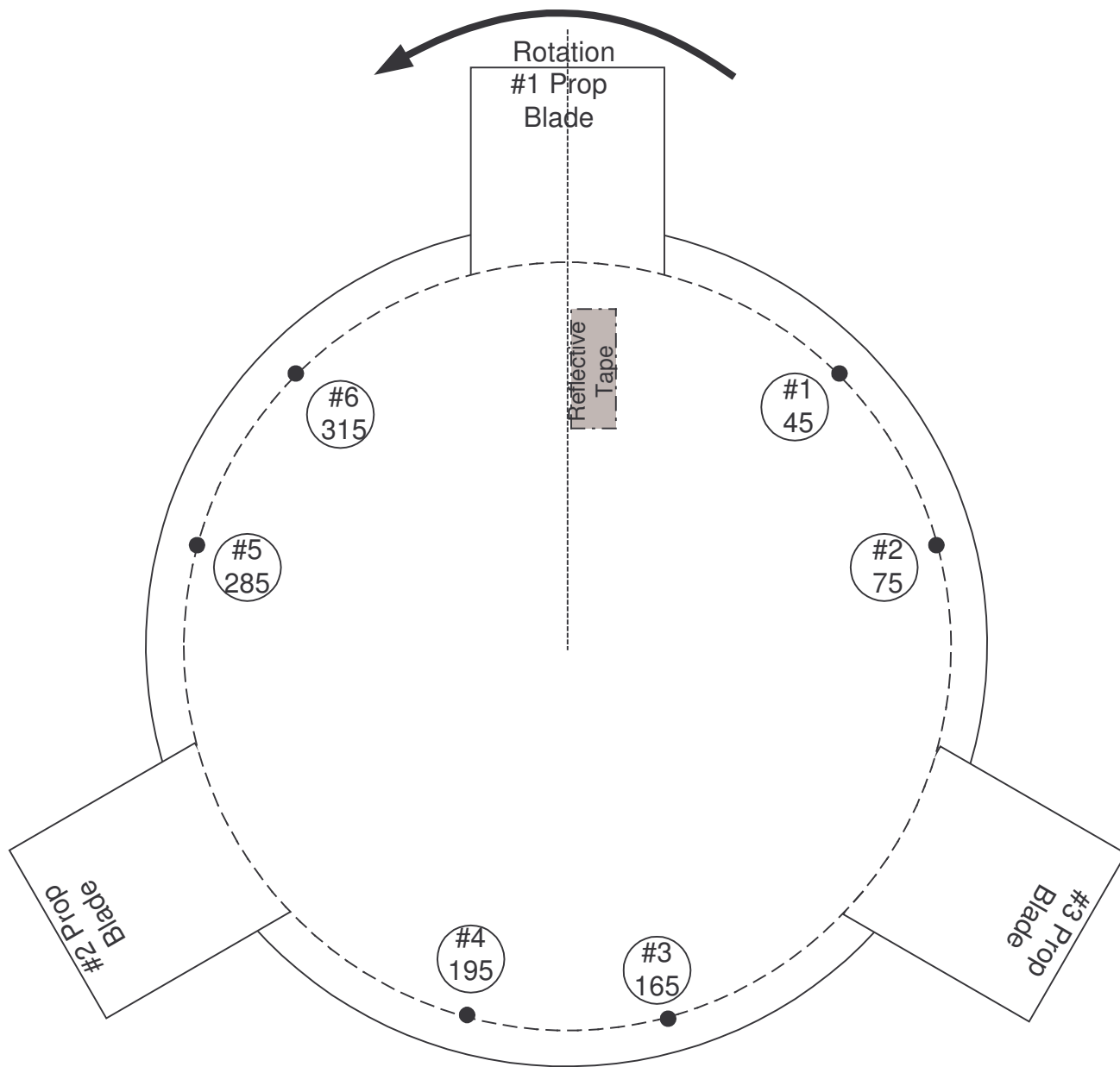

Figure 2.

As viewed from forward looking aft. The reflective tape is installed on the backside of the spinner bulkhead.

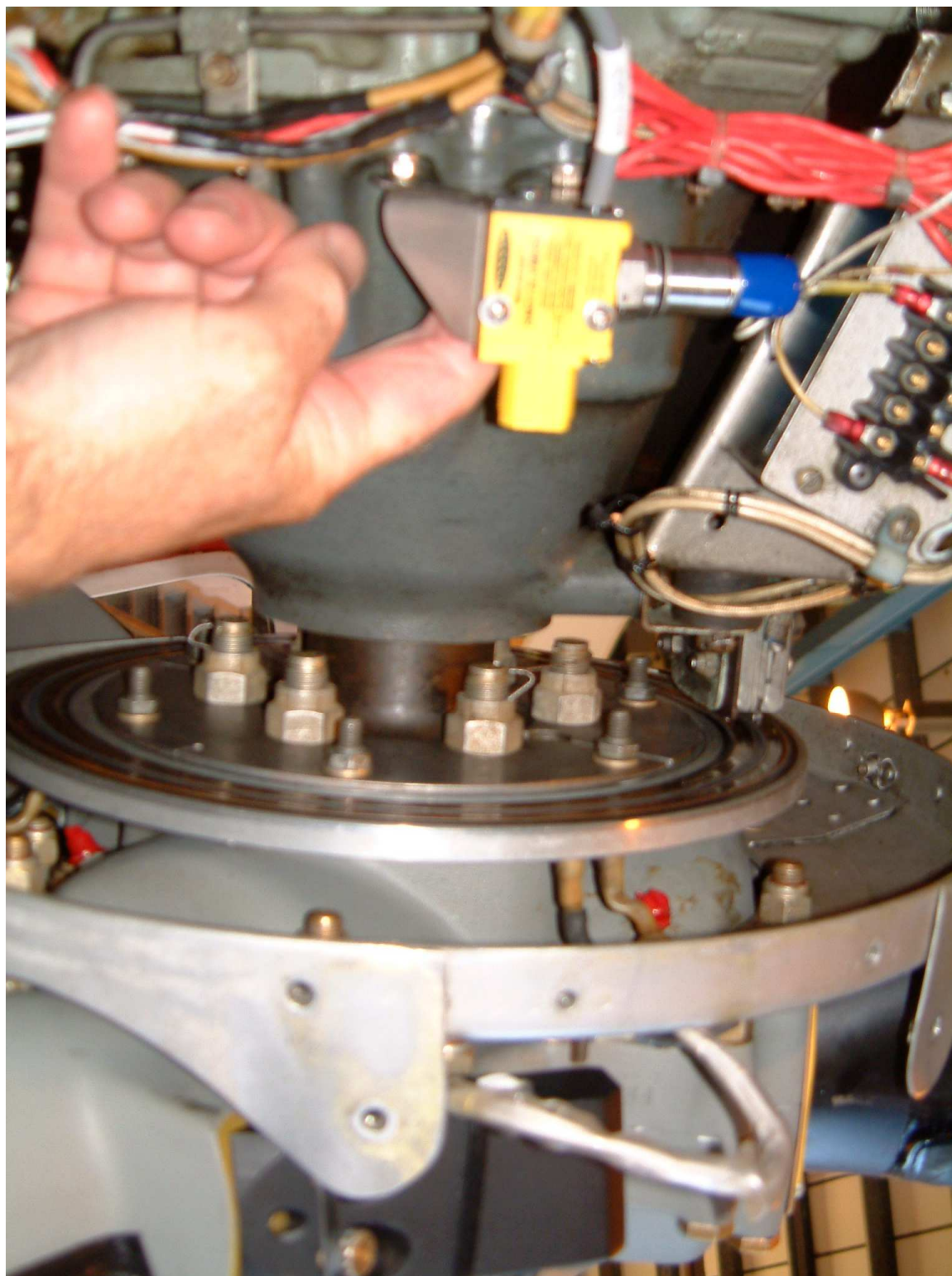
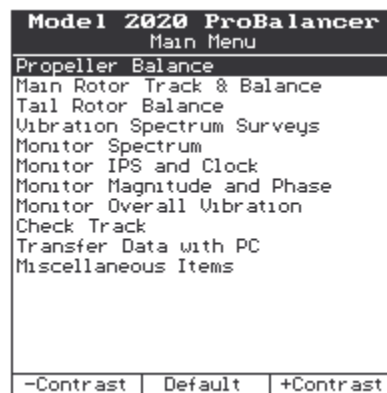

Figure 3

C. Analyzer Set Up

1. Insure the analyzer battery is charged prior to starting the job.
2. Turn the analyzer ON by pressing the ON/OFF key.
3. From the Main Menu, select “Propeller Balance” and press the [ENTER] key.



4. From the Propeller Balance Menu, select “Start Job” and press the [ENTER] key.

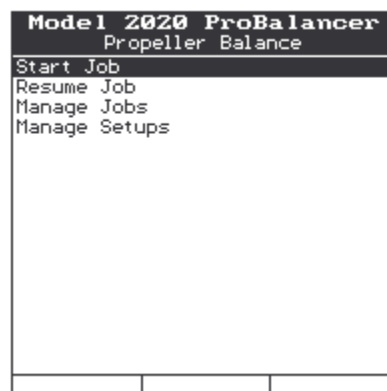

5. If the BN-2T Islander is listed in the Setup List, select it using the [DOWN ARROW] key, press [ENTER] and go to step 11 below. If the BN-2T is not in the Setup List, press the [F1], “New” key and go to step 6 below.

6. Complete the Prop Balance Setup screen per the illustration screen below.

Model 2020 ProBalancer		
Prop Balance Setup		
Name:	BN-2T ISLANDER	
Eng HP:	320	Num of Eng: (2)
Balancing RPM:	1827	
Max Baln. Wts:	76	Holes: (Yes)
Wts relative to:	(Tape)	
Rotation (#1):	(CCW)	(#2): (CCW)
Tach Type:	(Optical)	
Tach Pos (FLA):	Eng 1 (9):00	Eng 2 (9):00
Sens Type:	(991D-1)	
Sens Pos (FLA):	Eng 1 (12):00	Eng 2 (12):00
Edit ICF		Sensor

- A. In the “Name:” field, use the analyzer keypad to enter “BN-2T Islander”. Press the [DOWN ARROW] key to move to the next field.
- B. In the “Eng HP:” (Engine Horsepower) field, use the analyzer keypad to enter 320. “. Press the [DOWN ARROW] key to move to the next field.
- C. In the “Num of Eng:” field, press the [RIGHT ARROW] key until the field reads “2. “. Press the [DOWN ARROW] key to move to the next field.
- D. In the “Balancing RPM:” use the analyzer keypad to enter 1827. “. Press the [DOWN ARROW] key to move to the next field.
- E. In the “Max Baln. Wts:” field, use the analyzer keypad to enter 76. This is the maximum total amount of balance weights that may be added to the propeller assembly to accomplish the job. You will enter a maximum amount per hole in another screen. “. Press the [DOWN ARROW] key to move to the next field.
- F. In the “Holes:” field, press the [RIGHT ARROW] key until the field reads “Yes” to indicate there are pre existing holes where balance weights are added that must be defined. “. Press the [DOWN ARROW] key to move to the next field.
- G. In the “Wts relative to:” field, press the [RIGHT ARROW] key until the field reads “Tape”. This indicates the angle to each of the holes is measured relative to the position of the reflective tape on the propeller, which is used as an index point. “. Press the [DOWN ARROW] key to move to the next field.
- H. In the “Rotation #1:” field, press the [RIGHT ARROW] key until the field reads “CCW” for counter clockwise. “. Press the [DOWN ARROW] key to move to the next field and repeat this step for the #2 engine. “. Press the [DOWN ARROW] key to move to the next field.
- I. In the “Tach Type:” field, press the [RIGHT ARROW] key until the field reads “Optical” indicating you will use the optical Phototach. “. Press the [DOWN ARROW] key to move to the next field.

- J. In the “Tach Pos” (FLA): field for Eng 1, press the [RIGHT ARROW] key until the field reads “9:00”. This indicates the clock position where the phototach is triggered by the passage of the reflective tape, as viewed from forward of the engine looking aft toward the tail of the aircraft. Press the [DOWN ARROW] key to move to the next field and repeat this step for the “Eng 2” field. ”. Press the [DOWN ARROW] key to move to the next field.
- K. In the “Sens Type:” field, press the [RIGHT ARROW] key until the field reads “991D-1”.”. Press the [DOWN ARROW] key to move to the next field.
- L. In the “Sens Pos: (FLA) field for Eng 1, press the [RIGHT ARROW] key until the field reads “12:00”. This indicates the mounted axis relative to the prop shaft. Even though the sensor is physically mounted at the 9:00 o’clock position, its alignment is a vertical position relative to the propeller shaft. Press the [DOWN ARROW] key to move to the next field and repeat this step for the Eng 2 field. Press the [ENTER] key to continue.
7. The Prop Hole Layout Setup screen will be displayed as illustrated in the screen below. The “Name:” field will automatically be filled in from the previous screen above. Press the [DOWN ARROW] key to move to the “No. of Holes:” field. Use the analyzer keypad to enter “6” in the field. ”. Press the [DOWN ARROW] key to move to the next field.
8. In the “Space:” field, press the right arrow key until the field reads “Uneven”. The screen will immediately change to display the hole layout grid shown in step 9 below. Press the [DOWN ARROW] key to move to the next field

Model 2020 ProBalancer							
Prop Hole Layout Setup							
Name:	B-N ISLANDER						
No. of Holes:	6	Space:	Uneven				
Dir (FLA):	CW	Max H. Wt:	25				
Ang #	Ang #	Ang #	Ang #	Ang #	Ang #	Ang #	Ang #
45	1						
75	2						
165	3						
195	4						
285	5						
315	6						

9. Complete the remainder of the Prop Hole Layout Setup screen as follows:
- In the “Dir (FLA):” field, press the right arrow key until the field reads “CW” for clockwise. This is the direction of the hole numbering sequence for the installation. Press the [DOWN ARROW] key to move to the next field.
 - In the “Max H. Wt:” (Maximum Hole Weight) field, use the analyzer keypad to enter 25. Press the [DOWN ARROW] key to move to the next field
 - In the “Ang” (Angle) column corresponding to the #1 hole row, use the keypad to enter 45. This indicates that hole #1 is located at 45 degrees relative to the reflective tape at the center of the #1 blade. Notice that the “#” column is filled in automatically from 1 through 6. Use the [DOWN ARROW] key to move the cursor from field to field and enter the angles for each of the predefined hole numbers as shown in the screen below. Be careful not to accidentally enter an angle in the # column. When the fields are complete, recheck both columns for accuracy using the screen below as a guide. When complete, press the [ENTER] key to accept and continue.

Model 2020 ProBalancer							
Prop Hole Layout Setup							
Name: B-N ISLANDER							
No. of Holes: 6				Space: (Uneven)			
Dir (FLA): (CW)				Max H. Wt: 25			
Ang	#	Ang	#	Ang	#	Ang	#
45	1						
75	2						
165	3						
195	4						
285	5						
315	6						

10. The screen below will be displayed with the question “Store this new setup?” Press the [F1] “Yes” key to store the setup.

Model 2020 ProBalancer	
Model 2020 ProBalancer	
Store this new setup?	
Yes	No

11. The analyzer will proceed into the job with the screen below. At this time you may turn the analyzer OFF and start the job later by selecting the “B-N Islander” from the propeller balance setups or you may continue with the job. In the screen below, use the [RIGHT ARROW] key to select between “Both”, “Left”, or “Right” indicating the engine(s) you wish to balance. When the desired selection is displayed, press [ENTER] to continue.

Model 2020 ProBalancer Engine Selection		
You have selected a twin engine setup. Which engines do you wish to balance?		
Engine selection: <input type="text" value="Both"/>		

12. The Customer Information Screen will be displayed. Use the analyzer keypad to enter a customer name in the “Name:” field. The analyzer will maintain a list of customer names as new names are entered. If names have been previously entered into this analyzer, you may press the [F1] “Names” key and select a customers name from the provided list. Press the [DOWN ARROW] key to move to the next field and use the analyzer keypad to enter the optional aircraft registration and aircraft total time as required. When all fields are complete, press the [ENTER] key to accept and continue.

Model 2020 ProBalancer Customer Information		
Enter the following optional Customer Information.		
Name: <input type="text" value="CUSTOMER NAME"/>		
A/C Registration: <input type="text"/>		
A/C Total Time: <input type="text" value="0"/>		
Press ENTER to continue.		
Names		

13. The next screen to be displayed is the Engine Information screen. While all these fields are optional, we highly recommend you fill in as much information as possible to provide better record keeping and search functions in AvTrend. Use the key pad and the arrow keys to complete the fields for each engine. S/N = Serial Number. In the serial number field, you may press the [F1] “Serial Nos” key to select the serial number from a list if this number has previously been entered in this analyzer. Type = Type engine or prop. Pos = position (1 or 2). TSO = Time since overhaul and TSN = Time since new. All fields are filled in using the analyzer keypad except the Pos: field which is selected using the [RIGHT ARROW] key. When all fields are complete, press the [ENTER] key to continue.

Model 2020 ProBalancer	
Engine Information	
Engine 1 Info	Prop 1 Info
S/N: <input type="text"/>	<input type="text"/>
Type: <input type="text"/>	<input type="text"/>
Pos: (1)	
TSO: <input type="text"/>	
TSN: <input type="text"/>	
Engine 2 Info	Prop 2 Info
S/N: <input type="text"/>	<input type="text"/>
Type: <input type="text"/>	<input type="text"/>
Pos: (1)	
TSO: <input type="text"/>	
TSN: <input type="text"/>	
Serial Nos	<input type="text"/>

14. The next screen to be displayed will be the Prop Balance Equipment Setup screen as illustrated below. This screen gives instructions on installing sensors and cables. You may also check the Phototach alignment by pressing the [F1] “Tach On” key which supplies power to the optical tachometer for checking alignment with the reflective tape. If you choose to check alignment, press the [F1] key, rotate the propeller so that the tape is directly in front of the Phototach and check that the red led on the aft end of the Phototach is illuminated. Illumination indicates proper alignment. Press the [ENTER] key when finished with this screen to continue.

Model 2020 ProBalancer	
Prop Balance Equipment Setup	
Install Left eng speed sensor and connect to TACH Chan 1	
Install Right eng speed sensor and connect to tach chan 2	
Install Left vibration sensor to vibration channel A	
Install Right vibration sensor to vibration channel B	
Tach power is	Off
Tach On	<input type="text"/>

- The “Start Aircraft” screen will be displayed with instruction to “Remove all trim weights”. Remove all previously installed trim balance weights from all six hole locations to begin the balance with a clean slate. When you have verified that all weights are removed, press the [ENTER] key to continue.

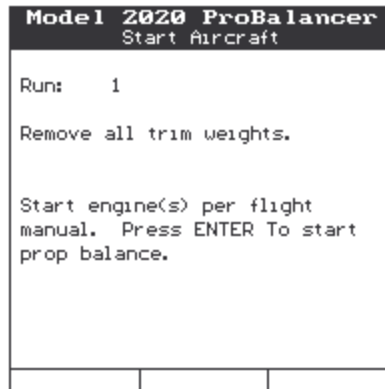

- The analyzer will display the Engine 1, Run 1 screen similar to the one below. Chapter 16 of the users manual gives detailed instructions on how to read the converging scale if you are not familiar with it. Increase RPM on the engine to a low cruise setting and allow the analyzer to collect data for approximately 10 to 15 seconds. The “Err: indication at the bottom of the text portion of the screen should be as steady as possible with very little change before you press [ENTER] to stop acquisition. If the Err % is not “0”, this is not an indication of failure or fault, only that the vibration averaging errors cannot be resolved below the displayed level. This Err % value will be higher as the balancing process reduces the vibration amplitude.

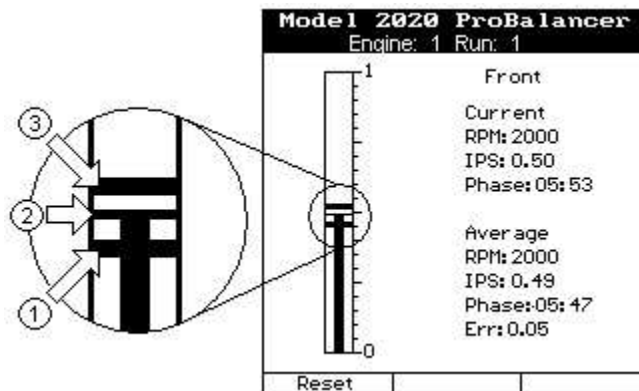

17. After pressing [ENTER] the review screen will be displayed as shown in the example below. This is the amplitude and phase angle reading for the left and right engines. You may retake either or both engines by pressing the appropriate function key [F1] through [F3] as indicated at the bottom of the screen. When satisfied with the acquired data, press the [ENTER] key to accept and continue.

Model 2020 ProBalancer							
Review Job							
	Left Eng		Right Eng				
Run	(IPS)	DEG.	(IPS)	DEG.			
1	0.30	60	0.22	35			
<table border="1" style="width: 100%; border-collapse: collapse;"> <tr> <td style="width: 33%;">Retake #1</td> <td style="width: 33%;">Retake #2</td> <td style="width: 33%;">Retake All</td> </tr> </table>					Retake #1	Retake #2	Retake All
Retake #1	Retake #2	Retake All					

18. The “Shutdown Aircraft” instruction screen will be displayed as shown in the example below. Shut down the engine using normal shutdown procedures. When all shutdown tasks are complete, press the [F3] “Continue” key.

Model 2020 ProBalancer		
Shut Down Aircraft		
Shut Down Aircraft per flight manual instructions		
		Continue

19. The Prop Suggested and Installed Weights screen shown below will be displayed. At the top of the screen you will see the Run number and engine identification (left or right). The left side of the screen shows the Suggested weight installation by actual weight and phase angle. Directly below the raw solution you will see a specific weight (in grams) in the left column and a corresponding hole number(s) in the right column where that weight should be installed. The Installed column at the right side of the screen is where you must enter the actual weight and hole number(s) where that weight was installed. Be as accurate as possible with the installed weight as the analyzer will use this information to calculate the follow on influence for the next solution (if required). Notice at the bottom of the screen the instructions: "Remove old, install & enter new weight." This means that ALL previously installed weights must be removed with each new weight installation. At the bottom of the screen, the three function keys are defined as: **[F1], Inst=Sugg**, press this key to default the Installed columns to the values displayed in the Suggested column. **[F2], Inst=None**, press this key to zero out all weight in the Installed column. **[F3], Quit Job**, press this key if you are satisfied with the current vibration levels and wish to terminate the balance job, leaving the previously installed weights in place. After the screen is complete per your actions, press the **[ENTER]** key to continue.

Model 2020 ProBalancer			
Prop Sugg. and Inst. Wts			
Run 1		Left Eng	
Suggested		Installed	
14.5	@ 150°	14.5	@ 150°
GMS	Hole	GMS	Hole
3.7	2	3.7	2
14.0	3	14.0	3
0.0	0	0.0	1
0.0	0	0.0	1
0.0	0	0.0	1
0.0	0	0.0	1

Remove old, inst. & enter new wt
ENTER to proceed to right eng.

Inst=Sugg	Inst=None	Quit Job
-----------	-----------	----------

20. If you chose to continue the job, the screen below will be displayed indicating you are ready to start engines for the next run. Steps 15 through 19 will be repeated until the vibration amplitude has been reduced to a satisfactory level, usually three runs or less total.