



Application Note

Bell 222, 230, 430 Series

Tail Rotor Balance

Part Number: 11-200-0149

AppNote Number: A-BE222-4040-TR (Rev. 3.0, Nov 2007)

This Application Note is provided for information only and does not supersede the requirements or guidelines set forth in the applicable engine or airframe maintenance manual. Technology for Energy Corporation assumes no obligation or liability, either expressed or implied, to the Purchaser arising out of the use of this procedure.

Copyright © 2007, TEC Aviation Division. All rights reserved. This document is to be printed and reproduced for personal use only.



Application Note

Application Note Number	A-BE222-4040-TR
Revision	3.0 (From Airframe Rev 2006)
Function	Tail Rotor Balance
Airframe	Bell 222, 230, 430 Series
Engine	N/A
E-Setup Number	a-be222-4040-tr.asf
ACES Systems Analyzer	Model 4040
Boot/App Version	3.05/3.05 or later
Procedure	N/A

Introduction

This Application Note covers the required equipment, equipment installation, analyzer setup, data acquisition and solution process for using the ACES Systems Model 4040 with the Tail Rotor Enhanced Performance Option to perform a tail rotor balance on the Bell 222, 230, 430 Series. General instructions for the use of the Model 4040 can be found in the Model 4040 User Manual #4040-OM-01 (P/N 75-900-4040). All procedures for balance and all adjustments should be made in accordance with the Airframe Maintenance Manual.

A. Required Equipment

The following equipment is required to perform a Tail Rotor Balance*:

Item	Quantity	Description	Part Number
1.	1	Analyzer, Model 4040	10-100-4040
2.	1	Tachometer, Optical, PhotoTach (New)	10-100-1773
3.	1	Cable, Tach, Generic, 50'	10-320-0126
4.	1	Sensor, Vibe, Accel, 991D-1	69-100-0075
5.	1	Cable, Sensor 991D-1, 50'	10-320-0163
6.	1	Tape, Reflective, Roll, 10'	10-400-0176
7.	1	Option, 4040 Main and Tail Rotor	11-900-0005
8.	1	Mount, PhotoTach, General Purpose	22-430-0066

*This listing shows the latest design parts. It is acceptable to perform this task using previous designs with the appropriate accessories. For compatibility issues, contact ACES Systems.



Miscellaneous Equipment

Tape or tie wraps to secure cables to airframe.

If adjustments are to be made to the tail rotor balance, use only hardware or balance weights that are specified in the applicable airframe maintenance manual.

B. Equipment Installation

1. Park the aircraft on a flat level surface with the nose into the wind. Place the analyzer (Item 1) in the flight compartment.

NOTE

See Paragraph D.2 below for additional installation instructions of PhotoTach and Tape.

2. Install 991D-1 Sensor (Item 4) through the hole in the General Purpose PhotoTach Mount (Item 8). Thread the Sensor into the tail rotor gearbox threaded insert at the 6:00 position and secure by tightening the Sensor. (Figure 1)
3. Install PhotoTach (Item 2) into the PhotoTach Mount and secure with nut.

NOTE

Secure and route cables as not to interfere with hot or rotating components.

4. Connect PhotoTach Cable (Item 3) to PhotoTach. Connect PhotoTach cable to “TACH 1” connector on the analyzer.
5. Connect Sensor Cable (Item 5) to Sensor and route both Cables into the cabin area. Connect Sensor Cable to “CHANNEL A” connector on the analyzer.
6. Reinstall any previously removed cowlings. Insure aircraft is safe for ground runs.

Equipment Installation Diagram

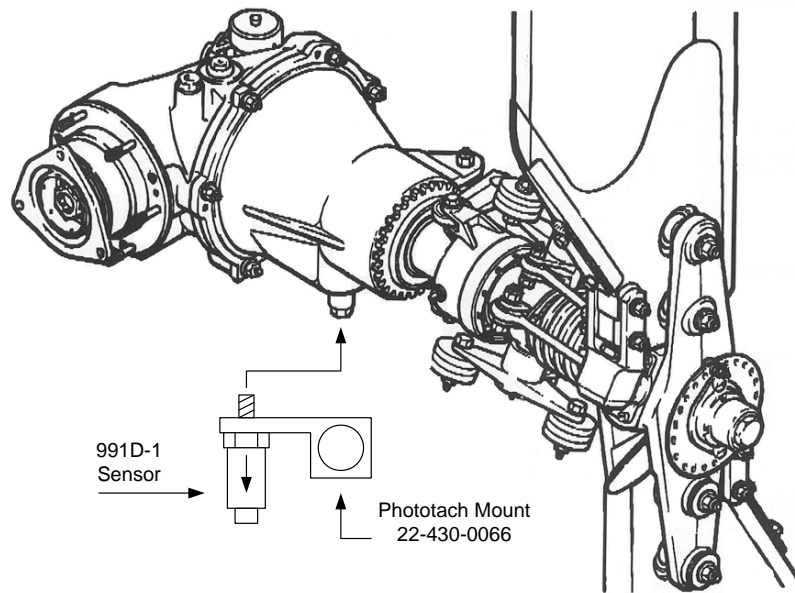
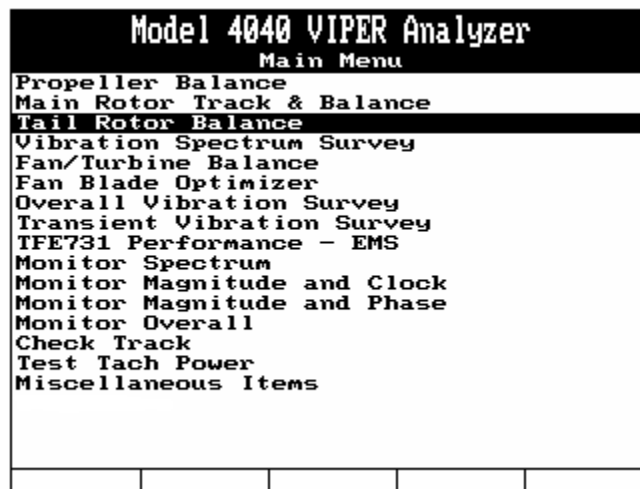

Figure 1

C. Analyzer Set Up

1. Insure the analyzer battery is charged prior to starting the job. See the Model 4040 User Manual #4040-OM-01 (P/N 75-900-4040) Chapter 2 for detailed instructions on battery charging.
2. Turn the analyzer ON by pressing the [ON/OFF] key.
3. From the Main Menu shown below, select “Tail Rotor Balance” and press the [ENTER] key.



4. From the Tail Rotor Balance Jobs Menu shown below, select “Start Job” and press the [ENTER] key.

Model 4040 VIPER Analyzer				
Tail Rotor Balance Jobs				
Start Job				
Resume Job				
Manage Jobs				
Manage Setups				

5. If the Bell 222, 230, 430 Series is listed in the Setup List, select it using the [↓] key, press [ENTER] and go to Section D below. If the Bell 222, 230, 430 Series is not in the Setup List, press the [F1], “New” key and go to Step 6 below.

Select				
Setup List				
1)	a-be222-4040-tr			
2)	BRAND X HELICOPTER			
3)	BRAND Y HELICOPTER			
4)	BRAND Z HELICOPTER			
New			Copy	

6. The “Tail Rotor Setup” screen now appears. Enter the Tail Rotor Setup as shown below. You can enter any name that is convenient for locating the setup in the future. When completed press [ENTER].

```

Model 4040 VIPER Analyzer
Tail Rotor Setup
Name: a-be222-4040-tr
Sensor Chan: A
Sensor: 991D-1

Tach Chan: 1
Tach Type: Optical
Tach Pos: 6

Balancing RPM: 1880
Rotor Direction: CW
Number of Blades: 2
Conditions: 1
Max Baln. Wts: 90.0

```

- The “Tail Rotor Chart Setup” screen will appear next. Enter the information as indicated in the illustration below. Press [ENTER] to continue.

```

Model 4040 VIPER Analyzer
Tail Rotor Chart Setup
Name: a-be222-4040-tr
Chart Type: Regular Num WtPos: 12
Grams/IPS: 90.000

```

WtPos	Add @	WtPos	WtPos
1	11 : 00	8	
2	10 : 00	9	
3		10	
4		11	
5		12	
6			
7			

WtPos MUST be in CW or CCW order

D. Data Acquisition

- The “Job Identification” Screen will be displayed, as shown below. Use the analyzer keypad to enter a customer name in the “Name:” field. The analyzer will maintain a list of customer names as new names are entered. If names have been previously entered into this analyzer, you may press the [F1] “Names” key and select a customers name from the provided list. Press the [↓] key to move to the next field and use the analyzer keypad to enter the optional aircraft registration and aircraft total time as required. When all fields are complete, press the [ENTER] key to accept and continue.

Model 4040 VIPER Analyzer				
Job Identification				
Name: CUSTOMER NAME				
A/C Registration: N1234				
A/C Total Time: 123.4				
Press ENTER to continue				
Names				

2. The next screen to be displayed will be the “Connect Sensors” screen as illustrated below. This screen gives instructions on installing sensors and cables. You may also check the PhotoTach alignment by pressing the [F1] “Tach Pwr” key which supplies power to the optical tachometer for checking alignment with the reflective tape.

Model 4040 VIPER Analyzer				
Connect Sensors				
Connect the Speed sensor to TACH channel 1				
Connect the VIB sensor to Vibration channel A				
Tach power is Off				
Tach Pwr				

- 2.1 Press [F1] “Tach Pwr”. Select a blade to be identified as the target blade. The balance hole closest to the centerline of this blade is designated as hole #12.
- 2.2 Hold a 2-inch piece of reflective tape (Item 6), reflective surface facing the PhotoTach, against the backside of the blade. Do not remove backing at this point.
- 2.3 The red “Gate” light on the back of the PhotoTach should illuminate as the reflective tape is properly aligned in front of the LED. Clean an area of the blade in preparation for mounting the reflective tape.
- 2.4 Remove the backing and install the reflective tape on the clean blade surface.
- 2.5 Adjust the PhotoTach to obtain an angle of approximately 5 degrees from perpendicular to the reflective tape. This will produce the best results when reading RPM.

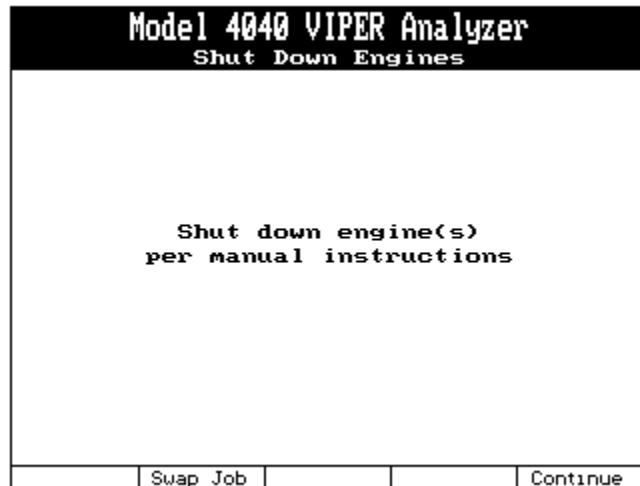

5. You will be prompted to “Shut down engine(s) per manual instructions” as shown above. Use the [F2] “Swap Job” key to return directly to the Main Menu without rebooting the analyzer. Press [F5] to proceed after engine shut down. The “Review Prior Run(s) Data” screen will appear as shown below. This screen allows the user to view the vibration readings that were acquired during the condition. Press [F1] to “Retake” the data or [ENTER] to continue. Pressing [F5] will “Quit Job”.

Model 4040 VIPER Analyzer			
Review Prior Run(s) Data			
Run	RPM	IPS	Clock
1	1884	0.400	3:18
Retake #1			

6. The “T/R Sugg. & Inst. Wts” screen will present a suggested solution based on the chart created in the original setup and the vibration IPS and clock reading. You have the opportunity to install the suggested weight corrections or decide on a different corrective action. It is important that the entry under the “Enter Installed Wts” reflect the actual weight amounts and locations used.

Model 4040 VIPER Analyzer			
T/R Suggested/Installed Weights			
Run 1 Suggestion:			
Chart: a-be222-2020-tr			
8	11.3	9	25.8
Enter Installed Weights:			
1	0.0	11	0.0
2	0.0	12	0.0
3	0.0		
4	0.0		
5	0.0		
6	0.0		
7	0.0		
8	11.0		
9	25.54		
10	0.0		
Inst=Sugg	Inst=None		Quit Job

CAUTION

At no point should a correction be made that contradicts information in the maintenance manual.

Using the keypad, record the actual weight(s) installed between runs and their location. Checking the Maintenance Manual, the closest possible combination of Bolt, Nut and Washers allows for 11.0 grams in Hole #8. The closest available combination for Hole #9 is 25.54 grams. The analyzer will round and display entries to a single decimal place. However, internally, the analyzer will continue to use the value entered. If you choose to remove weight from an opposite or alternate position, enter the negative adjustment. Do this by moving the highlight to the appropriate field, press the [SPACE+/-] key to produce a (-).

To remove all values in the suggested column use the [F2] "Inst=None" key. If you decide you would like to revert back to the suggested weights use [F1] "Inst=Sugg" key.

The [F5] "Quit Job" exits the balance job with no provisions to resume the job at a later point in time. If you wish to leave the job and be able to resume it later, press the [MAIN MENU] key.

- When you have finished with the solution process, press [ENTER] and you will be taken to the "Start Aircraft" screen as shown in Paragraph D.3 above to continue the balance process.

E. Quit Job

- Repeat Steps D.3 through D.7 above applying the solutions as necessary. When you are satisfied with the balance results, you can quit the job from any screen displaying the [F5] "Quit Job" key. Pressing this key will mark the job as complete and take you to Paragraph 2 below.
- Marking a job as complete will generate the screen shown below. Decide if you would like to update the ICF used in the original setup. Pressing [F1] "Yes" will add the chart corrections from this job to the ICF from the original setup. This can be a powerful tool when using this setup in the future. The chart corrections learned as a result of the previous job will be applied from the beginning of the next job that uses the same setup. This can reduce the number of runs required to balance the helicopter. If you select [F5] "No" any

chart corrections applied during the previous job will be discarded. The setup will revert to the chart settings in place before the job was started. This can be useful if the helicopter didn't respond as others of the same model or if a mistake was made somewhere during the job that caused extra runs to balance the helicopter.

Model 4040 VIPER Analyzer				
Update Setup ICFs?				
Do you want to update the setup's influence coefficients based on the result of this job?				
Yes				No

