



Application Note

Bell 206L Series

Tail Rotor Balance

Part Number: 11-200-0195

AppNote Number: A-BE206L-4040-TR (Rev. 0, Jun 2005)

This Application Note is provided for information only and does not supersede the requirements or guidelines set forth in the applicable engine or airframe maintenance manual. Technology for Energy Corporation assumes no obligation or liability, either expressed or implied, to the Purchaser arising out of the use of this procedure.

Copyright © 2005, TEC Aviation Division. All rights reserved. This document is to be printed and reproduced for personal use only.



Application Note

Application Note Number	A-BE206L-4040-TR
Revision	0 (From Airframe data Dated Apr 1996)
Function	Tail Rotor Balance
Airframe	Bell 206L Series
Engine	N/A
E-Setup Number	a-be206l-4040-tr.asf
ACES Systems Analyzer	Model 4040
Boot/App Version	1.04/1.05p3 or later
Procedure	N/A

Introduction

This Application Note covers the required equipment, equipment installation, analyzer setup, data acquisition and solution process for using the ACES Systems Model 4040 with the Tail Rotor Enhanced Performance Option to perform a tail rotor balance on the airframe listed above. General instructions for the use of the Model 4040 can be found in the Model 4040 User Manual #4040-OM-01 (P/N 75-900-4040) and Optical Tracker Operational Supplement #540-OM-1 (P/N 75-900-2021). All procedures for track and balance and all adjustments should be made in accordance with the Airframe Maintenance Manual.

A. Equipment Setup

Required Equipment: The following equipment is required to perform a Tail Rotor Balance:

Item	Quantity	Description	Part Number
1.	1	Analyzer, Model 4040	10-100-4040
2.	1	Option, 4040 Main and Tail Rotor	11-900-0005
3.	1	Tachometer, Optical, Phototach (New)	10-100-1773*
4.	1	Cable, Tach, Generic, 50'	10-320-0126*
5.	1	Sensor, Vibe, Accel, 991D-1	69-100-0075
6.	1	Cable, Sensor 991D-1, 50'	10-320-0163
7.	1	Tape, Reflective, Roll, 10'	10-400-0176
8.	1	Mount, Phototach/Sensor B407 & B206L	22-430-0106



*This listing shows the latest design parts. It is acceptable to perform this task using previous designs with the appropriate accessories. For compatibility issues, contact ACES Systems.

Miscellaneous Equipment

Tape or tie wraps to secure cables to airframe.

If adjustments are to be made to the tail rotor balance, use only hardware or balance weights that are specified in the applicable airframe maintenance manual.

B. Equipment Installation

1. Park the aircraft on a flat level surface with the nose into the wind. Place the Model 4040 Analyzer (Item 1) in flight compartment.

NOTE

See Paragraph D. 2 for additional installation instructions of Phototach and Tape.

2. Install the Phototach/Sensor Mount (Item 8) under the tail boom at the 6:00 position. (Figure 1) Install Phototach (Item 3) into Mount and secure with nut. Install the 991D-1 Sensor (Item 5) into Mount. Ensure that Sensor connector faces the tail rotor.

NOTE

Secure and route cables as not to interfere with hot or rotating components.

3. Connect the end of the 50' Tachometer Cable (Item 4) to the Phototach. Wrap the cable forward around the tail-boom away from rotating components to the cabin. Connect the opposite end of the cable to the "Tach 1" connector on the Analyzer.
4. Connect the 50' Vibration Sensor Cable (Item 6) to the Vibration Sensor. Wrap the cable forward around the tail-boom away from rotating components to the cabin. Connect the Cable to vibration "Channel A" on the Analyzer.

Equipment Installation Diagram

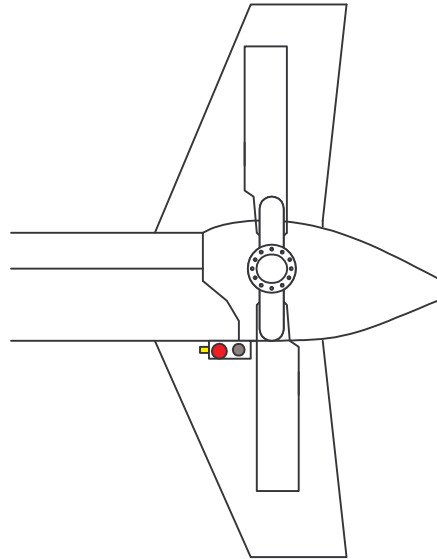

Figure 1

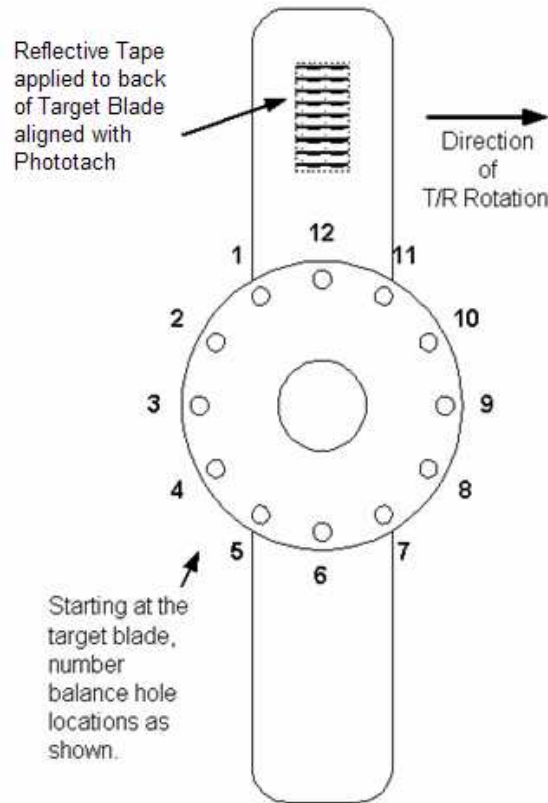
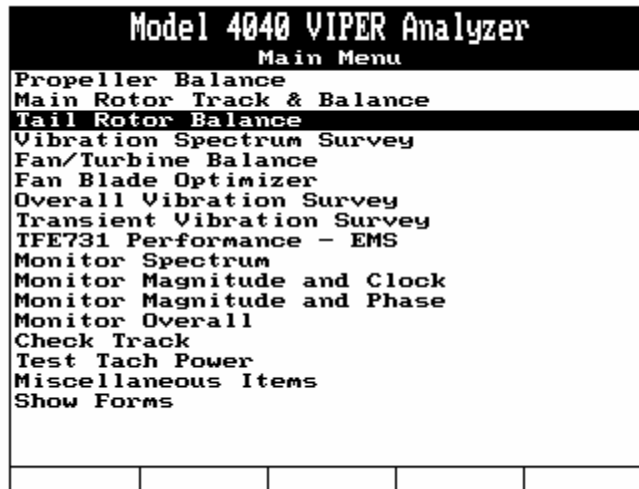

Figure 2



C. Analyzer Set Up

1. Insure the analyzer battery is charged prior to starting the job.
2. Turn the analyzer ON by pressing the [ON/OFF] key.
3. From the Main Menu shown below, select “Tail Rotor Balance” and press the [ENTER] key.



4. From the Tail Rotor Balance Menu shown below, select “Start Job” and press the [ENTER] key.



5. If the Bell 206L is listed in the Setup List, select it using the [↓] key, press [ENTER] and go to Section D below. If the Bell 206L is not in the Setup List, press the [F1], “New” key and go to step 6 below.

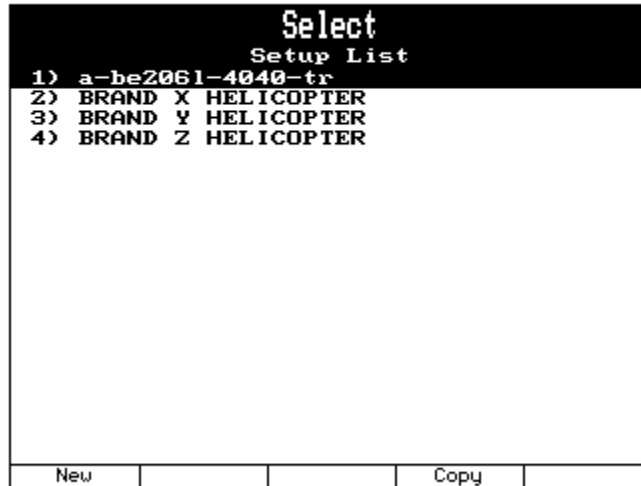

- The “Tail Rotor Setup” screen now appears. Enter the Tail Rotor Setup as shown below. You can enter any name that is convenient for locating the setup in the future. When completed press [ENTER].

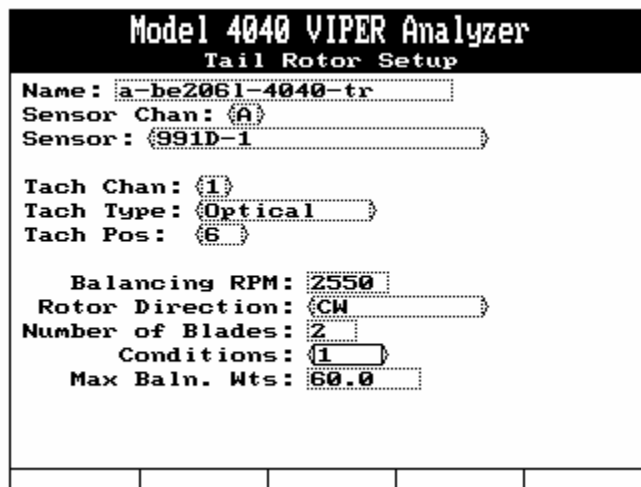

- The “Tail Rotor Chart Setup” screen will appear next as displayed below. Enter the information as indicated in the illustration below. Press [ENTER] to continue.

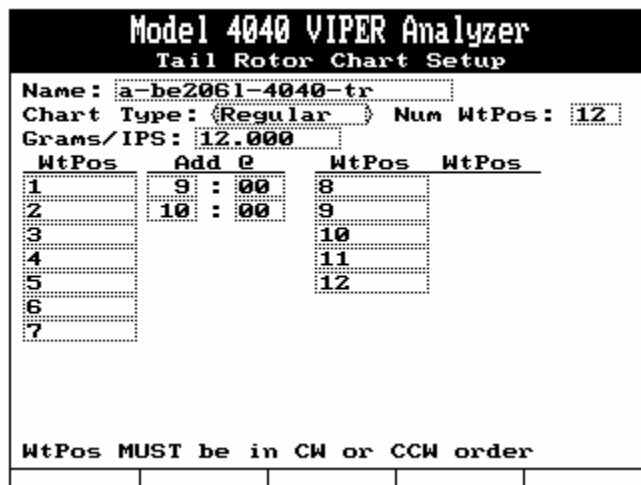

D. Data Acquisition

1. The Customer Information Screen will be displayed, as shown below. Use the analyzer keypad to enter a customer name in the “Name:” field. The analyzer will maintain a list of customer names as new names are entered. If names have been previously entered into this analyzer, you may press the [F1] “Names” key and select a customer's name from the provided list. Press the [↓] key to move to the next field and use the analyzer keypad to enter the optional aircraft registration and aircraft total time as required. When all fields are complete, press the [ENTER] key to accept and continue.

Model 4040 VIPER Analyzer				
Job Identification				
Name : CUSTOMER NAME				
A/C Registration: N1234				
A/C Total Time: 123.4				
Press ENTER to continue				
Names				

2. The next screen to be displayed will be the “Tail Rotor Equipment Setup” screen as illustrated below. This screen gives instructions on installing sensors and cables. You may also check the Phototach alignment by pressing the [F1] “Tach On” key which supplies power to the optical tachometer for checking alignment with the reflective tape.

Model 4040 VIPER Analyzer				
Tail Rotor Equipment Setup				
Install the speed sensor and connect to tach channel 1				
Install vibration sensor and connect to vib. channel A				
Tach power is Off				
Tach On				

- a. Press **[F1]** “Tach On”. Select a blade to be identified as the target blade. (See Section B Figure 2)
 - b. Hold a 2-inch piece of reflective tape, reflective surface facing the Phototach, against the backside of the blade. Do not remove backing at this point.
 - c. The red “Gate” light on the back of the Phototach should illuminate as the reflective tape is properly aligned in front of the LED. Clean an area of the blade in preparation for mounting the reflective tape.
 - d. Remove the backing and install the reflective tape on the clean blade surface.
 - e. As a counterbalance, place a similar piece of reflective tape on the outboard side of the Tail Rotor on the “BLANK” blade at the same distance from the hub.
 - f. Press **[ENTER]** when finished with Tape installation.
3. The “Start Aircraft” screen will be displayed with instructions to “Start Aircraft per Flight Manual”. When the aircraft is started and normal operating conditions have been established, press the **[ENTER]** key to continue.

```
Model 4040 VIPER Analyzer
Start Aircraft

Run 1

Start aircraft per flight manual.
Current Speed: 2540
Desired Speed: 2550
Difference: -10

When speed is stable at desired
speed, press ENTER to continue.
```

4. The analyzer will present the data acquisition screen as shown. This screen allows you to monitor both the current and averaged vibration readings. While monitoring the measurement, you may press the **[F1]** “Reset” key to restart the averaging process. Use this feature as a way to validate the quality of the measurement. If the averaged readings return to a value similar to that prior to being “Reset”, the measurement can be considered good. If the measurement is not similar, you may choose to “Reset” the average again.



See the Model 4040 User Manual #4040-OM-01 (P/N 75-900-4040) Chapter 20 for detailed instructions on how to read the “Converging Vibration Indicator and Scale.”

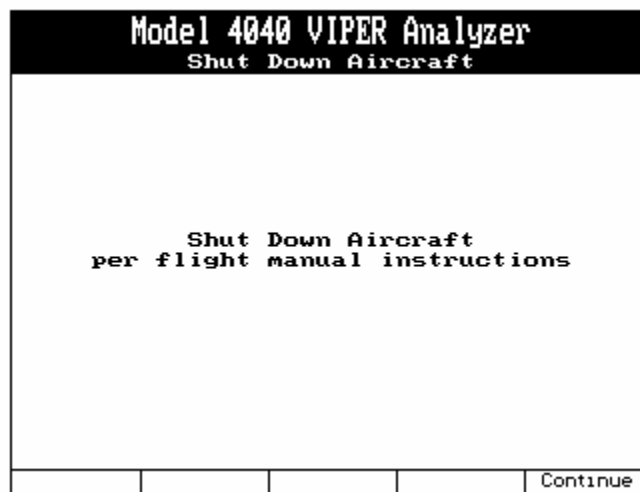

- You will be prompted to “Shut Down Aircraft” as shown above. Press **[F5]** to proceed. The “Review Prior Run(s) Data” screen will appear as shown below. This screen allows the user to view the vibration readings that were acquired during the condition. Press **[F1]** to “Retake” the data or **[ENTER]** to continue. Pressing **[F5]** will “Quit Job”.

Model 4040 VIPER Analyzer				
Review Prior Run(s) Data				
Run	RPM	IPS	Clock	
1	2500	0.430	2:32	
Retake #1				

- The “T/R Sugg. & Inst. Wts” screen will present a suggested solution based on the chart created in the original setup and the vibration IPS and clock reading. You have the opportunity to install the suggested weight corrections or decide on a different corrective action. It is important that the entry under the “Enter Installed Wts” reflect the actual weight amounts and locations used.

CAUTION

At no point should a correction be made that contradicts information in the maintenance manual.

Model 4040 VIPER Analyzer				
T/R Suggested/Installed Weights				
Run 1	Suggestion:			
Chart :	a-be2061-4040-tr			
6	2.5	7	2.8	
Enter Installed Weights:				
1	0.0	11	0.0	
2	0.0	12	0.0	
3	0.0			
4	0.0			
5	0.0			
6	2.5			
7	3.0			
8	0.0			
9	0.0			
10	0.0			
Inst=Sugg	Inst=None		Quit Job	

Using the keypad, record the actual weight(s) installed between runs and their location. As you can see in the example above, the correction actually installed was to add 2.5 grams in hole #6 and to add 3.0 grams in hole #7. If you choose to remove weight from an opposite or alternate position, enter the negative adjustment. Do this by moving the highlight to the appropriate field, press the [SPACE+/-] key to produce a (-).

To remove all values in the suggested column use the [F2] “Inst=None” key. If you decide you would like to revert back to the suggested weights use [F1] “Inst=Sugg” key.



The [F5] “Quit Job” exits the balance job with no provisions to resume the job at a later point in time. If you wish to leave the job and be able to resume it later, press the [MAIN MENU] key.

7. When you have finished with the solution process, press [ENTER] and you will be taken to the “Start Aircraft” screen as shown in paragraph 4 of this section to continue the balance process.

E. Quit Job

1. Repeat steps D.3 through D.7 applying the solutions as necessary. When you are satisfied with the results, from the screen shown in Paragraph D.6 above, pressing [F5] “Quit Job” will mark the job as complete.