



Application Note

Application Note Number	A-BE205-2020E-MR (Metal)
Revision	1
Function	Main Rotor Track and Balance
Airframe	Bell 205 Helicopter
Engine	N/A
E-Setup Number	A-BE205-2020E-MR(M).asf
ACES Systems Analyzer	Model 2020 w / Main Rotor Enhanced Firmware
Firmware Version	2.00 or greater
Procedure	N/A

Introduction

This outline covers the required equipment, equipment installation, analyzer setup, data acquisition, and solution process for using the ACES Model 2020 with the Main Rotor Enhanced Performance Software option to perform a main rotor track and balance on the **Bell 205 helicopter fitted with metal main rotor blades**. General instructions for the use of the Model 2020 can be found in user manual #2020OM-01. All adjustments to the aircraft are to be performed I/A/W the Bell 205 Maintenance Manual.

A. Required Equipment

The following ACES Systems' equipment is required.

Item	Quantity	Description	Part Number
1.	1	Model 2020 Analyzer	10-100-2020
2.	1	Optical Tracker Model 540-2	75-900-0542
3.	2	Sensor, Vibration, 991D-1	69-100-0075
4.	1	Cable, Sensor, 25'	10-320-0162
5.	1	Cable, Sensor, 50'	10-320-0163
6.	1	Pickup, Magnetic Speed Sensor	75-900-0187
7.	1	Interrupter	22-430-0098
8.	1	Cable, Magnetic Pickup, 25'	10-320-0052
9.	1	Bracket, Magnetic Pickup	22-430-0088

10.	1	Mount, Vibe Sensor, .250" "L"	22-430-0035
11.	1	Mount, Vibe, Sensor, 5/16"	22-430-0036

Miscellaneous Equipment

Tape or tie wraps to secure cables to airframe.

B. Equipment Installation

1. Install one 991D-1 vibration sensor into "L" bracket (P.N. 22-430-0035) and attach to the left side of the instrument panel with the connector pointing **DOWN**. Connect sensor cable (P/N 10-320-0162) to sensor and route to analyzer. Connect to channel A.
2. Install one 991D-1 vibration sensor into "L" bracket (P.N. 22-430-0036) and attach to the forward wall of the main transmission pylon with the connector pointing out the **LEFT** hand side of the aircraft. Connect sensor cable (P/N 10-320-0163) to sensor and route to analyzer. Connect to channel B.
3. Install the magnetic pickup bracket (P/N 22-430-0088) to the **Left** stationary swashplate arm and secure. Install magnetic pickup into bracket and temporarily install. Rotate the main rotor until the red blade is forward. With the red blade forward, install the interrupter (P/N 10-430-0098) on the rotating swashplate. The red blade is now designated as the target blade. The white blade is the blank blade.
4. Rotate the main rotor to align the interrupter with the pickup. Adjust interrupter gap to 0.050" +/- 0.010", secure and safety pickup.
5. Connect the magnetic pickup cable (P/N 10-320-0052) to the pickup. Secure the cable to the mast fairing with duct tape. Route the cable down to the lower front of the left doorframe. Secure the cable. Pull the collective stick full up and cyclic full left and check for binding of the magnetic pickup cable.
6. Connect the end marked "Analyzer" of the magnetic pickup cable (P/N 10-320-0052) to tachometer channel "1" on the Model 2020.
7. Connect the Model 540-2 Tracker to the "Aux./Comm" port on the Model 2020.

Equipment Installation Diagram

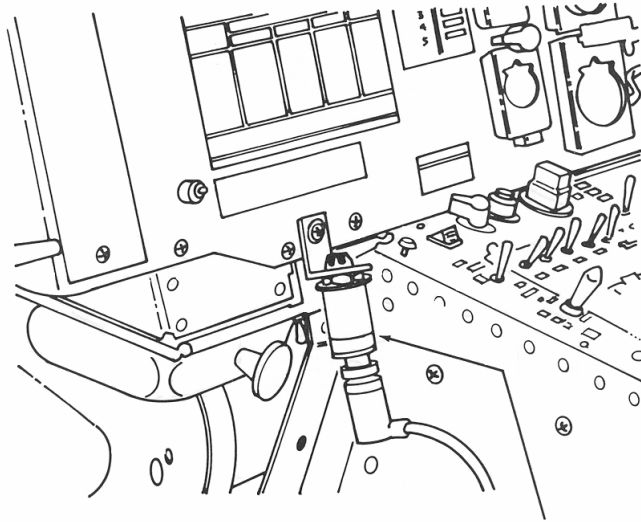

Sensor

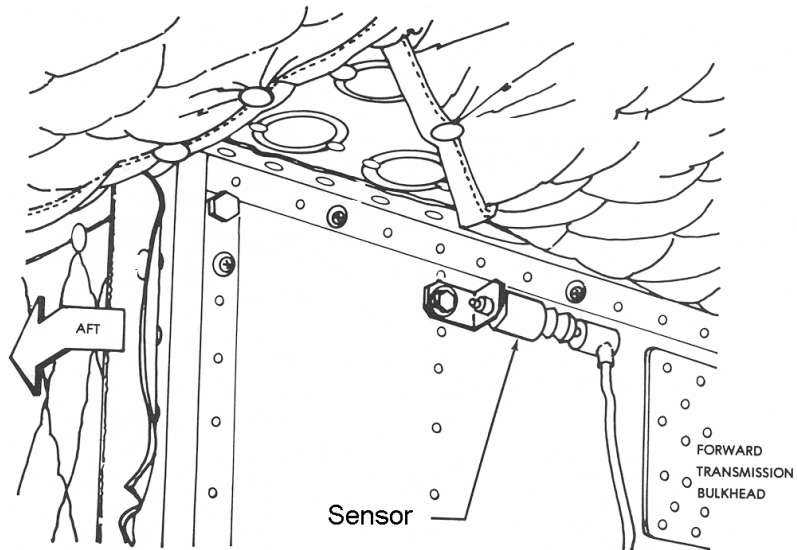

Sensor

Left Cyclic Horn

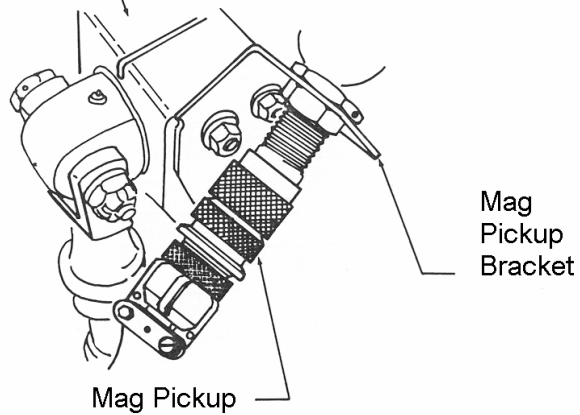

Mag Pickup Bracket

Mag Pickup

C. Analyzer Set Up

1. Turn the analyzer “ON”
2. From the “Main Menu”, select “Main Rotor Track and Balance” and press [Enter].
3. From the “Main Rotor Track and Balance” menu, select “Manage Setups” and press [Enter].
4. From the “Manage Setups” menu, select “Edit” and press [Enter].
5. If setups are already stored in the analyzer, a setup list will be presented. If the Bell 205 is not among this list, press the [F-1] key for a “New” setup. If there are no setups stored, the “Job Setup” screen will be presented, proceed to step “6”.

Warning

It is important that the following setup information be entered exactly as shown, as errors may lead to possible failure of jobs performed with this setup.

6. The “Main Rotor Setup” screen now appears. Enter the main rotor job setup information as shown in the appropriate fields. When completed, press [Enter].

Model 2020 ProBalancer
Main Rotor Setup

Name: BELL 205 METAL
 Vertical Chan: (A)
 Lateral Chan: (B)
 Sensor: (9910-1)
 Tach Type: (Mag(Hi))
 Tach Chan: (1) WtPos: (4)
 Blades: (2) Relative to: (1)
 RPM: (324) Trk Units: (in)
 << Conditions >>
 Ground (Both) Hover (Both)
 60KTS (Both) 90KTS (Both)
 110KTS (Both) (Both)

7. The “Main Rotor Conditions Setup” screen will be presented. Here, you will define the number and type of charts to be used when calculating corrections for a given measurement. Chart “ID’s” of similar measurements with the same number will average the readings together for use in solutions. The “limit” field under each measurement type will set the point at which the analyzer will determine whether corrections are needed. Enter the information exactly as it appears in the appropriate fields. When completed, press [Enter].

Model 2020 ProBalancer
Main Rotor Conds. Setup

	Vert Chart ID	Lat Chart ID	Track Adj. ID
Ground	0	1	1
Hover	0	1	1
60KTS	1	0	2
90KTS	1	0	2
110KTS	1	0	2
Limit	0.20	0.10	0.25

Enter ID=0 if no adjustment.
Diff charts use diff IDs.

- The “M/R Adjustment Symbol Setup” screen is displayed next. The function of this screen is to determine the direction of movement for a + adjustment. Enter the values as shown. When complete press [Enter].

Note: Sweep adjustments called out by the analyzer are aft sweep adjustments. Never sweep a blade forward.

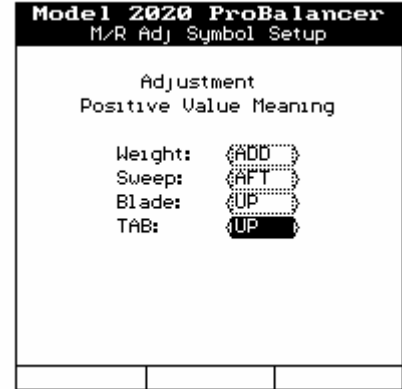

- The first main rotor chart to define will be the “Vertical: 60-110 KTS” chart. This chart will determine the trim tab adjustments to perform for forward flight vibration measurements. Enter the information exactly as it appears in the appropriate fields. When completed, press [Enter].

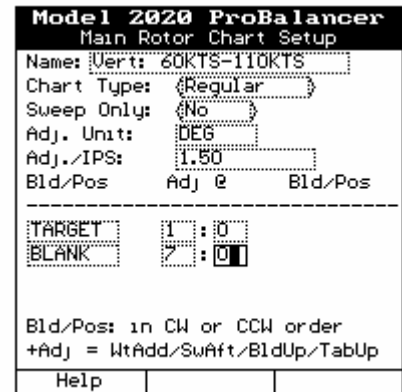

- Next, the “Lateral: Ground-Hover” chart will appear. This chart will determine the lateral balance adjustments to perform for ground/hover lateral measurements. Enter the information exactly as it appears in the appropriate fields. When completed, press [Enter].

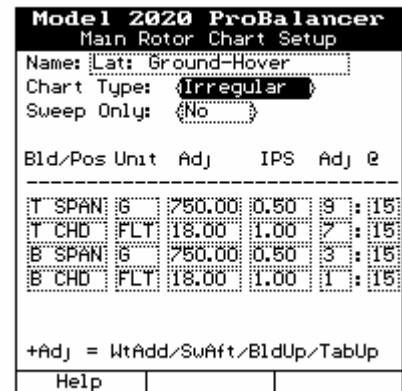

11. Last, the “Tracking Influence Setup” screen appears. This chart will determine the pitch change link adjustments required for blade separation at ground/hover and tab bends required for in-flight track adjustments. The “Adj./in.” sensitivity is for making “fine” adjustments of the PCL barrel. Enter the information exactly as it appears in the appropriate fields. When completed, press **[Enter]**.

Model 2020 ProBalancer			
Tracking Influence Setup			
Conds	AdjName	Unit	Adj./in
Ground-Hover	PCL	Fit	2.60
60KTS-110KTS	TAB	Deg	.5
+Adj = WtAdd/SuAft/BldUp/TabUp			

12. Setup complete, press **[Backup]**, select “Start Job”, press **[Enter]** and then select the Bell 205 Metal Main Rotor Setup that was just created.

Select	
Setup List	
1 >	BELL 205 METAL
2 >	BELL 212 MAIN ROTOR
3 >	EC 120 M/R
4 >	AS365 MAIN ROTOR
New	

D. Data Acquisition

1. “Customer Information” screen. It is recommended to complete this screen so that customer information will appear on printout assisting in identification of the job when it is stored in the analyzer memory. When finished press **[Enter]**.

Model 2020 ProBalancer Customer Information		
Enter the following optional Customer Information.		
Name:	COMPANY NAME	
A/C Registrations:	N12345	
A/C Total Time:	1005	
Press ENTER to continue.		
Names		

2. “Tracking Selections” screen. Allows the user to select tracking device for this particular job. Select Tracker or Strobe and press **[Enter]**.

Model 2020 ProBalancer Tracking Selections		
Track Device:	Tracker	
- For Optical Tracking Only		
Number of Rotations:	20	
Inches To Blade Tip:	135	

3. Main Rotor Equipment Setup. Information screen that prompts the user to verify equipment installation has been performed in accordance with channel selections that were specified when building the setup. Press **[Enter]**.

Model 2020 ProBalancer Main Rotor Equipment Setup		
Install the speed sensor and connect to TACH Channel 1		
Install vertical vibration sensor to vibration channel A		
Install lateral vibration sensor to vibration channel B		
Tach power is off		
Tach On		

- “Start Aircraft” screen. This screen allows the user to view the current main rotor rpm. When the aircraft has been started press **[Enter]**.

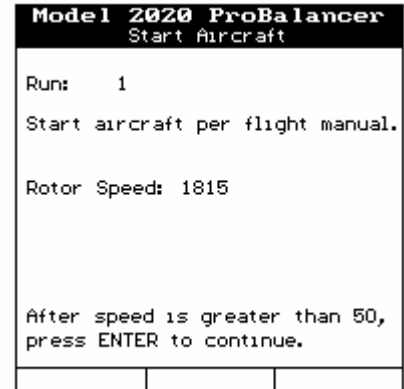

- “Select Aircraft Condition” screen. Displays the ground and flight regimes that are specified in the setup. Select Ground and press **[Enter]**.

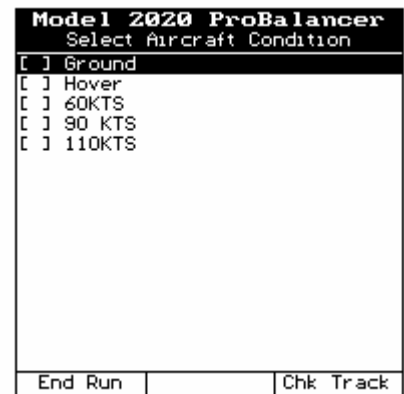

- Acquiring Vibration Data. This screen is displayed during the vibration acquisition. When stable vibration readings are observed, press **[Enter]**.

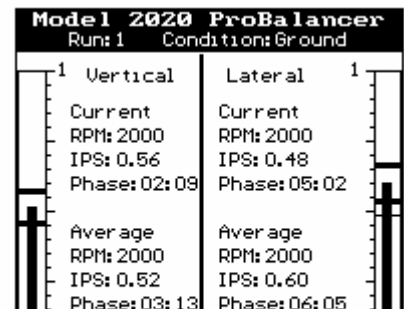

- Review Data. This screen allows the user to view the vibration readings that were acquired during the

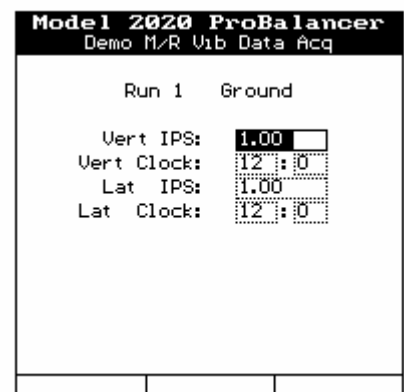

regime. Press **[Enter]** to continue or **[F3]** to take track data. Once track data is acquired continue to next flight regime as prompted by the balancer. Continue until all balance points and track reading are obtained.

8. The “Track Screen” will appear prompting you to aim and fire the tracker. Aim the tracker at the tip of the rotor disk at the 12:00 position. Move tracker up and down until green LED’s are illuminated. Press trigger one time and continue to hold tracker with green LED’s illuminated. The amber LED will pulsate during the acquisition. When tracker acquisition is complete the amber LED will extinguish.

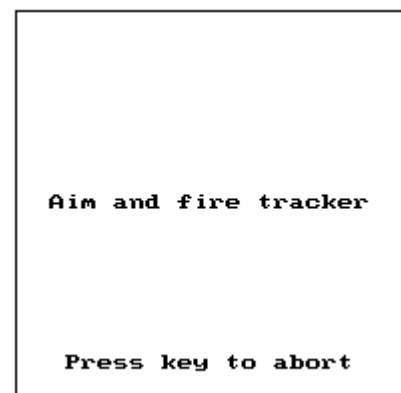

9. The track data will now appear on the screen. The track split will be shown. If the number of packets recorded is less than 75% of the total, press **[Enter]** and then **[F-1]** to retake the track reading. After review press **[Enter]** to continue.

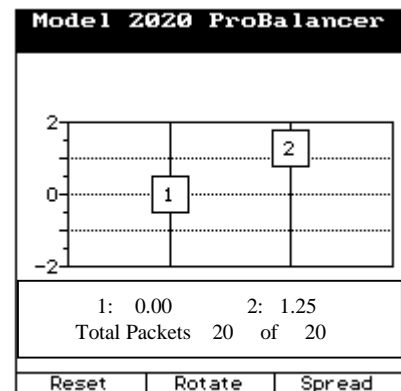

10. The “Review Data” screen will reappear, press **[Enter]** to continue.

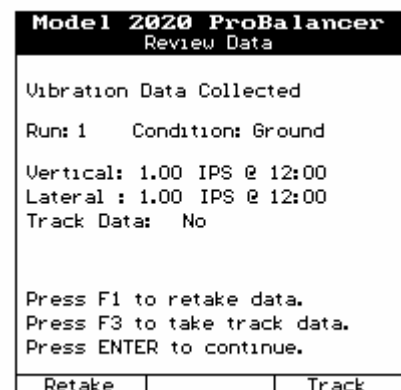

Note

At any time during a flight if the vibration levels are found to be too severe to continue, the user has the option to end run and solve for the vibration data acquired to that point.

11. Repeat sequence through all flight regimes. After all data is acquired press the “Adjust” [F-2] button, shut down the aircraft and review solution options.

Model 2020 ProBalancer		
Select Aircraft Condition		
[x]	Ground	
[x]	Hover	
[x]	60KTS	
[x]	90 KTS	
[x]	110KTS	
End Run	Adjust	Chk Track

Model 2020 ProBalancer		
Shutdown Aircraft		
Shutdown aircraft per flight manual instructions.		
Press ENTER to continue.		

12. The analyzer will present all of the solutions possible from the data gathered. It is possible for the analyzer to give two adjustments that would adversely affect the other. The user is ultimately responsible for determining which adjustments to implement and which to discard. Make the desired adjustments to the rotor system as called for by analyzer and press [Enter].

The user will now be prompted to start the engine and continue with run #2.

Model 2020 ProBalancer		
M/R Sugg. and Inst. Adj		
Run 1		
Name: Vert: 60KTS-110KTS, DEG		
Bld/Pos	Suggested	Installed

TARGET	1.30	1.30
BLANK	0.00	0.00
+Adj = WtAdd/SwAft/BldUp/TabUp		
Inst=Sugg	Inst=None	Quit Job

Model 2020 ProBalancer		
M/R Sugg. and Inst. Adj		
Run 1		
Name: Lat:Ground-Hover, G, FLT		
Bld/Pos	Suggested	Installed

T SPAN	1066.36	1066.36
T CHD	0.00	0.00
B SPAN	0.00	0.00
B CHD	20.58	20.58
+Adj = WtAdd/SwAft/BldUp/TabUp		
Inst=Sugg	Inst=None	Quit Job

Model 2020 ProBalancer		
M/R Sugg. and Inst. Adj		
Run 1		
Name: Trk:Ground-Hover, PCL, Flt		
Bld/Pos	Suggested	Installed

TARGET	0.00	0.00
BLANK	-2.60	-2.60
+Adj = WtAdd/SwAft/BldUp/TabUp		
Inst=Sugg	Inst=None	Quit Job

Note

It is important to remember that when installing or removing weights and recording their positions that the influence used for the next run will be updated by the result from the previous run's solution, therefore be as accurate as possible when recording adjustments made regardless whether the recommended solution is implemented. The only entries on this screen should reflect the actual solution implemented.



Application Note

Bell 205

Main Rotor Balance

Part Number: 11-200-0050

AppNote Number: a-be205-2020e-mr

This Application Note is provided for information only and does not supercede the requirements or guidelines set forth in the applicable engine or airframe maintenance manual. Technology for Energy Corporation assumes no obligation or liability, either express or implied, to the Purchaser arising out of the use of this procedure.

Copyright © 2001, TEC Aviation Division. All rights reserved. This document is to be printed and reproduced for personal use only.