



Application Note

Bell 204/205/UH1 Old Style W/Bal Arms

Tail Rotor Balance

Part Number: 11-200-0010

AppNote Number: A-BE204-OLDWA-2020-TR (Rev. 4, May 2006)

This Application Note is provided for information only and does not supersede the requirements or guidelines set forth in the applicable engine or airframe maintenance manual. Technology for Energy Corporation assumes no obligation or liability, either expressed or implied, to the Purchaser arising out of the use of this procedure.

Copyright © 2001 - 2006, TEC Aviation Division. All rights reserved. This document is to be printed and reproduced for personal use only.



Application Note

Application Note Number	A-BE204-OLDWA-2020-TR
Revision	4 (From other data dated 1975)
Function	Tail Rotor Balance
Airframe	Bell 204/205/UH1 Old Style with Baln Arms
Engine	N/A
E-Setup Number	a-be204oldwa-2020-tr.asf
ACES Systems Analyzer	Model 2020 Series with EPS
Boot/App Version	3.03/3.03 or later
Procedure	N/A

Introduction

This Application Note covers the required equipment, equipment installation, analyzer setup, data acquisition and solution process for using the ACES Systems Model 2020 with the Tail Rotor Enhanced Performance Software (EPS) option to perform a tail rotor balance on the airframe listed above. General instructions for the use of the Model 2020 can be found in the Model 2020 User Manual #2020-OM-01 (P/N 75-900-2020) and Enhanced Performance Software Operational Supplement #2020-OM-02 Supplement 1 (P/N 75-900-2022). All procedures for balance and all adjustments should be made in accordance with the Airframe Maintenance Manual.

A. Equipment Setup

Required Equipment: The following equipment is required to perform a Tail Rotor Balance:

Item	Quantity	Description	Part Number
1.	1	Analyzer, Model 2020	10-100-2020
2.	1	Tachometer, Optical, Phototach (New)	10-100-1773*
3.	1	Cable, Tach, Generic, 50'	10-320-0126*
4.	1	Sensor, Vibe, Accel, 991D-1	69-100-0075
5.	1	Cable, Sensor 991D-1, 50'	10-320-0163
6.	1	Mount, 1/4X28 Sensor, Vibe 5/16" Hole, S/Stl	22-430-0036
7.	1	Tape, Reflective, Roll, 10'	10-400-0176
8.	1	Option, 2020 Enhanced Tail Rotor	11-900-0002**



9.	1	Mount, Phototach, General Purpose	22-430-0066
----	---	-----------------------------------	-------------

*This listing shows the latest design parts. It is acceptable to perform this task using previous designs with the appropriate accessories. For compatibility issues, contact ACES Systems.

**Using the Enhanced Tail Rotor Option will require entries on screens not found in the standard 2020 software. If your 2020 does not display all of the following screens, contact ACES Systems to learn about the benefits and availability of EPS.

Miscellaneous Equipment

Tape or tie wraps to secure cables to airframe.

If adjustments are to be made to the tail rotor balance, use only hardware or balance weights that are specified in the applicable airframe maintenance manual.

B. Equipment Installation

1. Park the helicopter on a level surface with the nose into the wind. Place the Model 2020 Analyzer (Item 1) in flight compartment.
2. Install the Phototach Mount (Item 9) on the stud of the 991D-1 Vibration Sensor (Item 4). Thread the Vibration Sensor into the Vibration Sensor Mount (Item 6). (Figure 1)
3. Remove nut from upper-right stud of the Tail Rotor Gearbox flange and install the Vibration Sensor Mount on the stud. (Figure 2)
4. Install the Phototach (Item 2) through the hole in the Phototach Mount so that the lens of the Phototach faces the back side of the Tail Rotor. Secure with the nylon nut or sunshield. (Figure 2)

NOTE

See Paragraph D.2 for additional installation instructions of Phototach and Tape.

5. Connect the 50' Tach Cable (Item 3) to the pigtail on the Phototach. Route the cable safely into the flight compartment and secure as necessary. Connect the analyzer end of the cable to the "TACH 1" connector.
6. Connect the 50' Vibe Sensor Cable (Item 5) to the Vibration Sensor. Route the cable safely into the flight compartment and secure as necessary. Connect the analyzer end of the cable to the "CHANNEL A" connector.

NOTE

Secure and route cables as not to interfere with hot or rotating components.

7. Reinstall any previously removed cowlings.

Equipment Installation Diagram

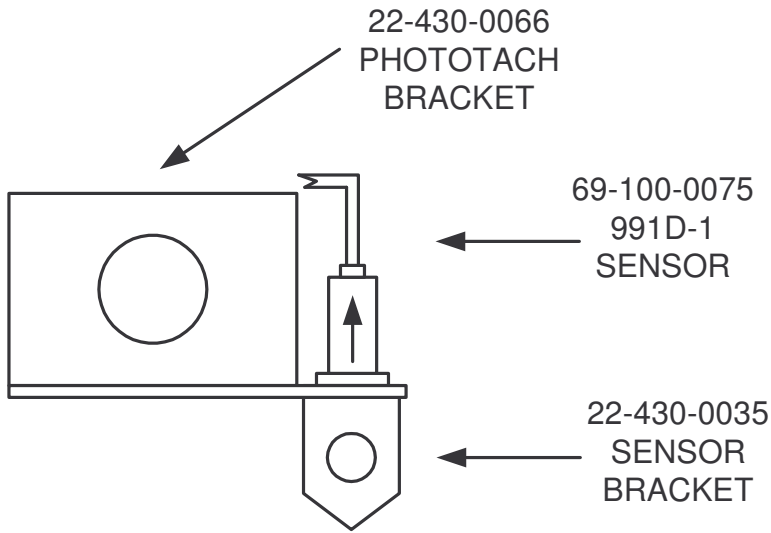

Figure 1

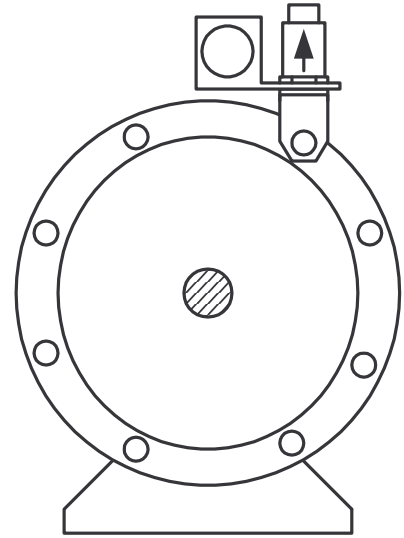

Figure 2

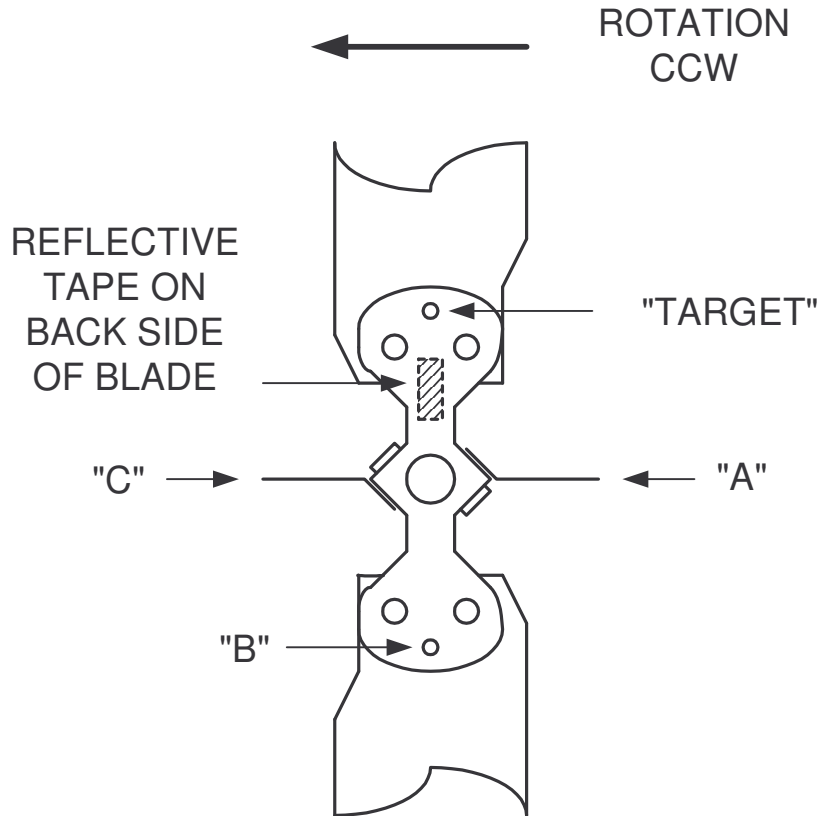
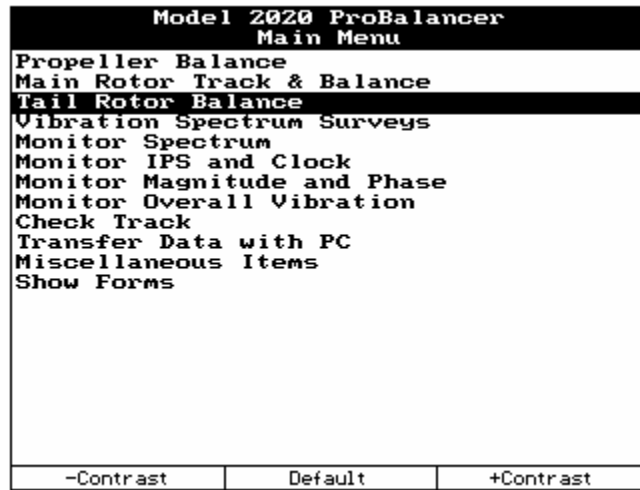

Figure 3



C. Analyzer Set Up

1. Insure the analyzer battery is charged prior to starting the job. See the Model 2020 User Manual #2020-OM-01 (P/N 75-900-2020) Chapter 2 for detailed instructions on battery charging.
2. Turn the analyzer ON by pressing the [ON/OFF] key.
3. From the Main Menu shown below, select “Tail Rotor Balance” and press the [ENTER] key.



4. From the Tail Rotor Balance Menu shown below, select “Start Job” and press the [ENTER] key.

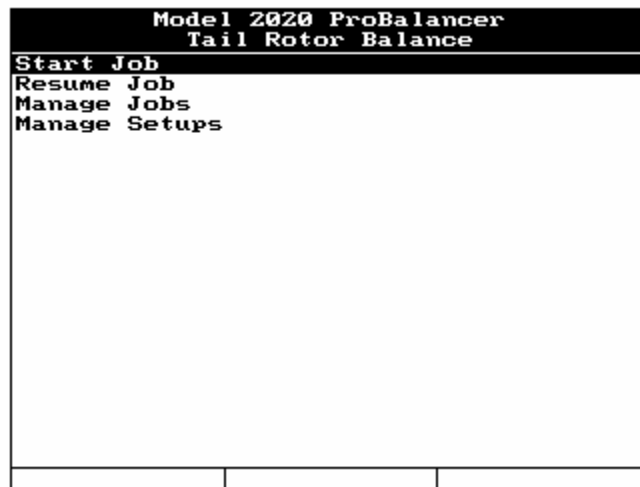

5. If the Bell 204/205/UH1 Tail Rotor is listed in the Setup List, select it using the [↓] key, press [ENTER] and go to Section D below. If the Bell 204/205/UH1 Tail Rotor is not in the Setup List, press the [F1], “New” key and go to step 6 below.

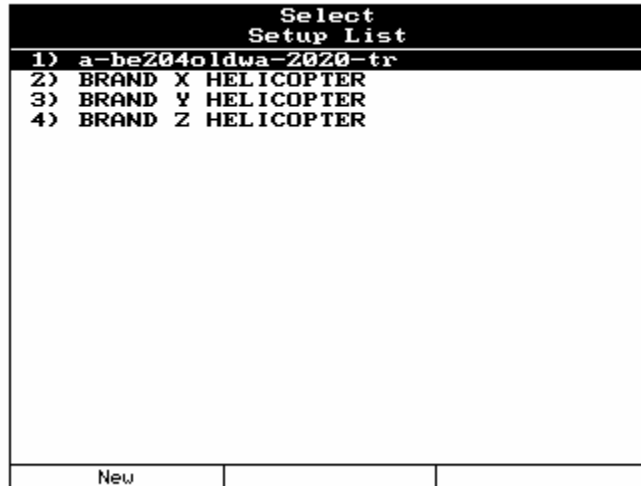

- The “Tail Rotor Setup” screen now appears. Enter the Tail Rotor Setup as shown below. You can enter any name that is convenient for locating the setup in the future. When completed press [ENTER].

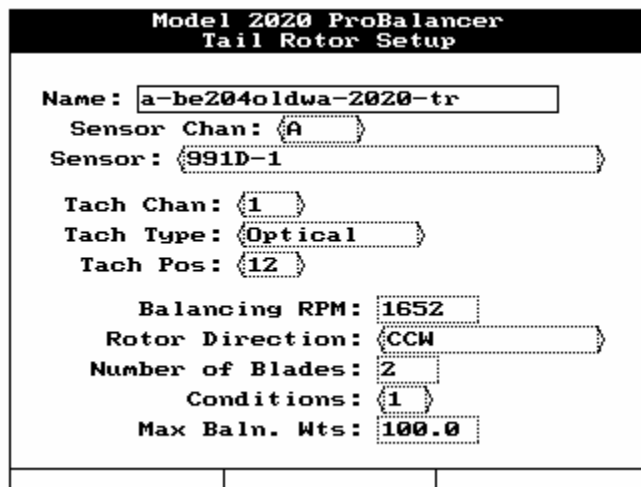

- The “Tail Rotor Chart Setup” screen will appear next as displayed below. Enter the information as indicated in the illustration below. Press [ENTER] to continue.

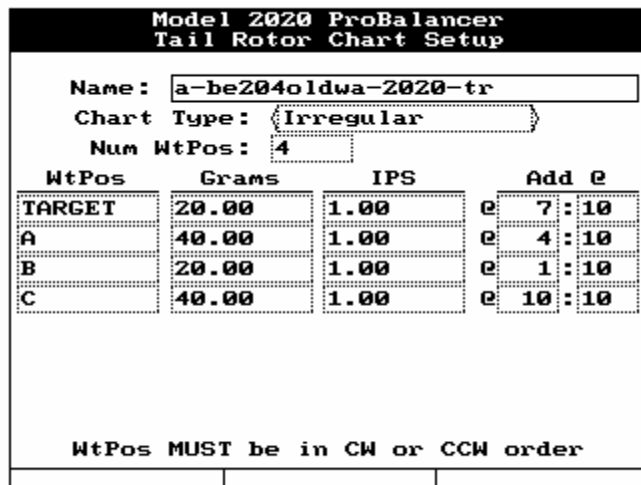

D. Data Acquisition

1. The “Customer Information” screen will be displayed, as shown below. Use the analyzer keypad to enter a customer name in the “Name:” field. The analyzer will maintain a list of customer names as new names are entered. If names have been previously entered into this analyzer, you may press the [F1] “Names” key and select a customer's name from the provided list. Press the [↓] key to move to the next field and use the analyzer keypad to enter the optional aircraft registration and aircraft total time as required. When all fields are complete, press the [ENTER] key to accept and continue.

Model 2020 ProBalancer Customer Information		
Enter the following optional Customer Information.		
Name:	CUSTOMER NAME	
A/C Registration:	N1234	
A/C Total Time:	123.4	
Press ENTER to continue.		
Names		

2. The next screen to be displayed will be the “Connect Sensors” screen as illustrated below. This screen gives instructions on installing sensors and cables. You may also check the Phototach alignment by pressing the [F1] “Tach Pwr” key which supplies power to the optical tachometer for checking alignment with the reflective tape.

Model 2020 ProBalancer Connect Sensors		
Connect the Speed sensor to TACH channel 1		
Connect the VIB sensor to Vibration channel A		
Tach power is Off		
Tach Pwr		

- a. Press [F1] “Tach Pwr”. Select a blade to be identified as the target blade. (See Section B Figure 3)

- b. Hold a 2-inch piece of reflective tape (Item 7), reflective surface facing the Phototach, against the backside of the blade. Do not remove backing at this point.
 - c. The red “Gate” light on the back of the Phototach should illuminate as the reflective tape is properly aligned in front of the LED. Clean an area of the blade in preparation for mounting the reflective tape.
 - d. Remove the backing and install the reflective tape on the clean blade surface.
 - e. Press [ENTER] when finished with Tape installation.
3. The “Start Aircraft” screen will be displayed with instructions to “Start Aircraft per Flight Manual”. When the aircraft is started and normal operating conditions have been established, press the [ENTER] key to continue.

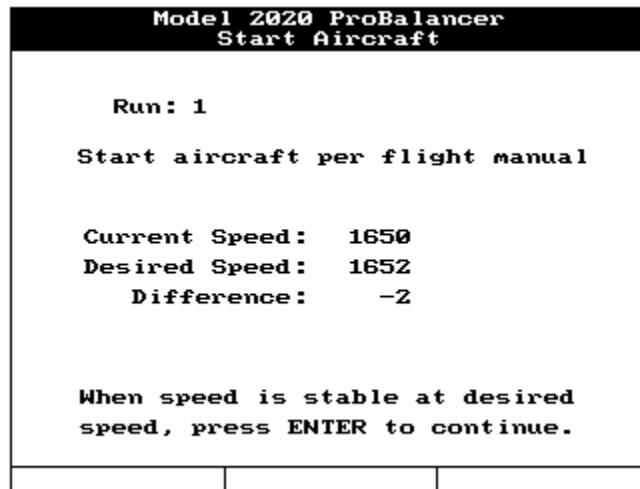

4. The analyzer will present the data acquisition screen as shown. This screen allows you to monitor both the current and averaged vibration readings. While monitoring the measurement, you may press the [F1] “Reset” key to restart the averaging process. Use this feature as a way to validate the quality of the measurement. If the averaged readings return to a value similar to that prior to being “Reset”, the measurement can be considered good. If the measurement is not similar, you may choose to “Reset” the average again.

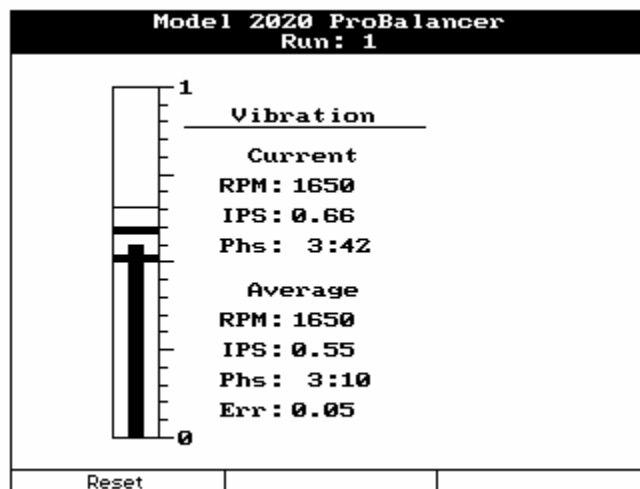

See the Model 2020 User Manual #2020-OM-01 (P/N 75-900-2020) Chapter 16 for detailed instructions on how to read the “Converging Vibration Indicator and Scale.”

- You will be prompted to “Shut Down Aircraft”. Press [F3] to proceed. The “Review Prior Run(s) Data” screen will appear. This screen allows the user to view the vibration readings that were acquired during the condition. Press [F1] to “Retake” the data or [ENTER] to continue. Pressing [F3] will “Quit Job”.

Model 2020 ProBalancer Review Prior Run(s) Data			
Run	RPM	IPS	Clock
1	1650	0.550	3:10
Retake #1		Quit Job	

- The analyzer will present a warning screen similar to the one shown below. Since all weight suggestions are in addition to the previous tail rotor condition, you are cautioned not to exceed the limit defined in the setup. Press [F3] “Continue” to acknowledge the warning and proceed.

Model 2020 ProBalancer * WARNING *	
<p>The maximum tail rotor weight defined in the setup is 100.00 grams.</p> <p>You must ensure that the total weight does not exceed 100.00 grams, regardless of what the analyzer suggests.</p>	
Continue	

- The “T/R Sugg. & Inst. Wts” screen will present a suggested solution based on the chart created in the original setup and the vibration IPS and clock reading. You have the opportunity to install the suggested weight corrections or decide on a different corrective action. It is important that the entry under the “Enter Installed Wts” reflect the actual weight amounts and locations used. In the example below the suggested correction is to install 19.1 grams on the “A” weight location and install 5.5 grams on the “B” weight location. The

closest available weight combination was to add 20.0 grams to “A” and 6.0 grams to “B”. The correction is made on the aircraft and the corresponding entry entered in the analyzer.

Model 2020 ProBalancer T/R Sugg. & Inst. Wts	
Run 1 Suggestion:	
A	19.1 B 5.5
Enter Installed Wts	
TARGET	0.0
A	20.0
B	6.0
C	0.0
Inst=Sugg Inst=None Quit Job	

CAUTION

At no point should a correction be made that contradicts information in the maintenance manual.

Using the keypad, record the actual weight(s) installed between runs and their location. If you choose to remove weight from an opposite or alternate position, enter the negative adjustment. Do this by moving the highlight to the appropriate field, press the [SPACE+/-] key to produce a (-).

To remove all values in the suggested column use the [F2] “Inst=None” key. If you decide you would like to revert back to the suggested weights use [F1] “Inst=Sugg” key.

The [F3] “Quit Job” exits the balance job with no provisions to resume the job at a later point in time. If you wish to leave the job and be able to resume it later, press the [MAIN MENU] key.

- When you have finished with the solution process, press [ENTER] and you will be taken to the “Start Aircraft” screen as shown in Paragraph 3 of this section to continue the balance process.

E. Quit Job

1. Repeat steps D.3 through D.8 applying the solutions as necessary. When you are satisfied with the balance results, you can quit the job from any screen displaying the [F3] “Quit Job” key. This will mark the job as complete and take you to Paragraph 2 below.
2. From this screen, decide if you would like to update the ICF used in the original setup. Pressing [F1] “Yes” will add the chart corrections from this job to the ICF from the original setup. This can be a powerful tool when using this setup in the future. The chart corrections learned as a result of the previous job will be applied from the beginning of the next job that uses the same setup. This can reduce the number of runs required to balance the helicopter. If you select [F3] “No” any chart corrections applied during the previous job will be discarded. The setup will revert to the chart settings in place before the job was started. This can be useful if the helicopter didn’t respond as others of the same model or if a mistake was made somewhere during the job that caused extra runs to balance the helicopter.

Model 2020 ProBalancer Update Setup ICFs?	
Do you want to update the setup's influence coefficients based on the result of this job?	
Yes	No