



Application Note

ATR 42/72

Propeller Balance

Part Number: 11-200-0234

AppNote Number: A-ATR42-2020-PB

This Application Note is provided for information only and does not supersede the requirements or guidelines set forth in the applicable engine or airframe maintenance manual. Technology for Energy Corporation assumes no obligation or liability, either expressed or implied, to the Purchaser arising out of the use of this procedure.

Copyright © 2007, TEC Aviation Division. All rights reserved. This document is to be printed and reproduced for personal use only.



Application Note

Application Note Number	A-ATR42-2020-PB
Revision	5
Function	Propeller Balance
Airframe	ATR42 /72
Engine	PW100
E-Setup Number	a-atr42-2020-pb.asf
ACES Systems Analyzer	Model 2020
Firmware Version	3.1 or higher
Procedure	N/A

Introduction

This Application Note covers the required equipment, equipment installation, analyzer setup, data acquisition and solution process for using the ACES Systems Model 2020 to perform a Propeller balance on the airframe listed above. General instructions for the use of the Model 2020 can be found in the Model 2020 User Manual. All procedures for Propeller Balance and all adjustments should be made in accordance with the Aircraft Maintenance Manual.

A. Required Equipment

The following ACES Systems equipment is required*:

Item	Quantity	Description	Part Number
1.	1	ANALYZER, MODEL 2020HR	10-100-2020HR
2.	1	CABLE, INTERFACE, 991V-TO-ATR42/72	10-320-0294
3.	1	SENSOR, VIBE, VELO, 991V	69-100-0064
4.	1	CABLE, INTERF, ATR-42-TO-2020/4040	10-320-0185

*This listing shows the latest design parts. It is acceptable to perform this task using previous designs with the appropriate accessories. For compatibility issues, contact ACES Systems.

Optional Equipment

The following ACES Systems equipment will be required to balance both engines during a single run.



Item	Quantity	Description	Part Number
5.	1	CABLE, INTERFACE, 991V-TO-ATR42/72	10-320-0294
6.	1	SENSOR, VIBE, VELO, 991V	69-100-0064

Miscellaneous Equipment

Standard AN washers for balance weights (see maintenance manual for ACES Guide to Propeller Balancing for acceptable hardware).

B. Equipment Installation

1. Place analyzer (Item 1) in flight compartment.
2. Obtain access to the engine mounted vibration sensor (or dummy sensor) mounted on the gearbox.

NOTE

Secure and route cables as not to interfere with hot or rotating components.

3. Disconnect the sensor cable from the installed sensor (or dummy sensor) and from the bulkhead. Install the 991V to ATR42/72 Interface cable, item 2, to the bulkhead where the previously installed cable was attached. (See Figure 1.) To balance both engines during a single run, repeat the above procedure on the second engine using a second interface cable, item 5.
4. Remove the installed sensor (if not a functional 991V sensor) and install the 991V Vibe Sensor (Item 3) into the mounting hole. Connect the 991V to ATR42/72 interface cable, item 2, to the now installed 991V vibration sensor. Repeat this procedure for the second engine using a second 991V vibration sensor, item 6.
5. Reinstall any previously removed engine cowlings.
6. Connect the ATR-42 to 2020/4040 interface cable, Item 4, to the Prop Balance test connector located on the bulkhead behind the co-pilots seat. (See Figure 2.)
7. Connect the six pin vibration connectors of the ATR42/72 interface cable, marked L (left) and R (right) or 1 and 2 to the six pin vibration inputs of the 2020 analyzer as required. The left (#1 engine) connection should go to CHANNEL A and the right (#2 engine) connection should go to CHANNEL B.
8. Connect the three pin tachometer connectors for the ATR42/72 interface cable, marked L (left) and r (right) or 1 and 2, to the three pin TACH connectors of the 2020 analyzer as required. The left (#1 engine) connection should go to TACH 1 and the right (#2 engine) connection should go to CHANNEL B.

Equipment Installation Diagram

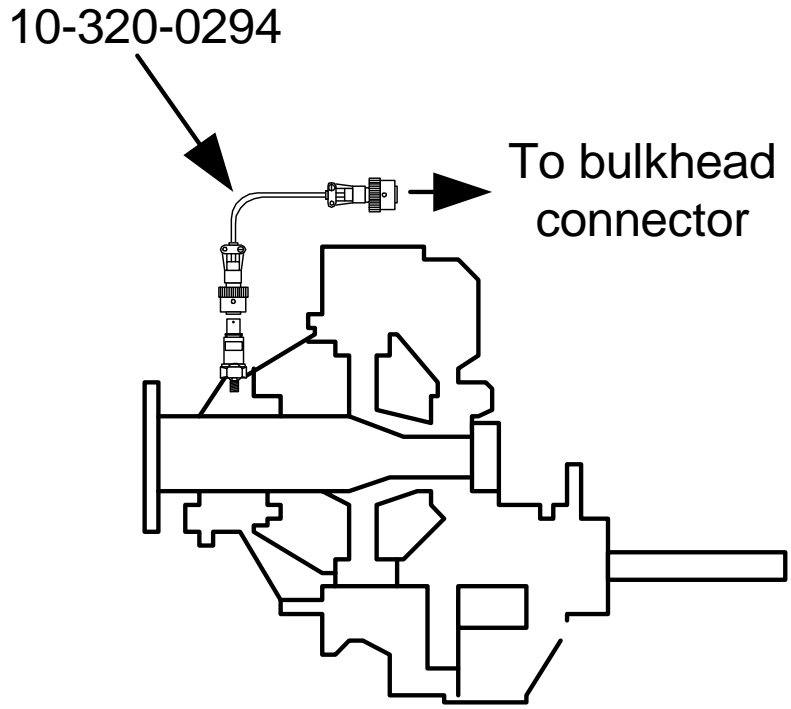

Figure 1

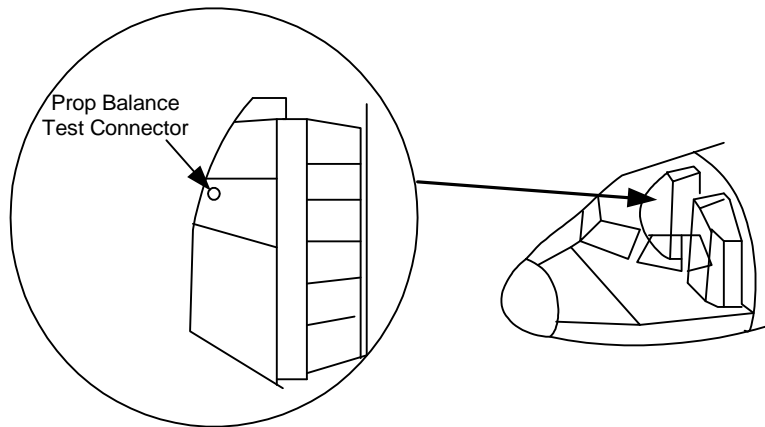
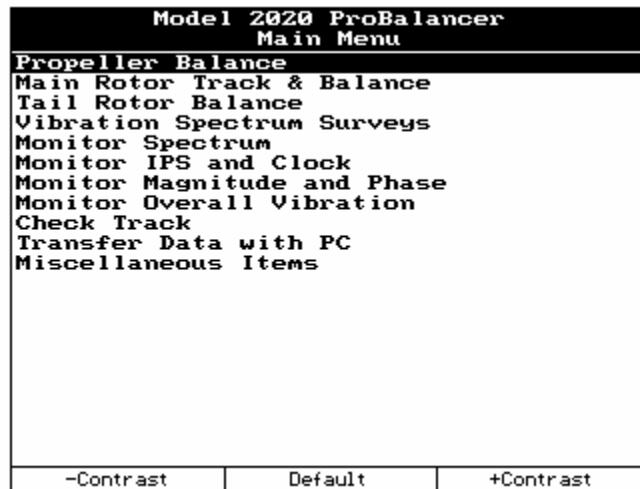

Figure 2



C. Analyzer Set Up

1. Insure the analyzer battery is charged prior to starting the job.
2. Turn the analyzer ON by pressing the [ON/OFF] key.
3. From the Main Menu, select “Propeller Balance” and press the [ENTER] key.



4. From the Propeller Balance Menu, select “Start Job” and press the [ENTER] key.

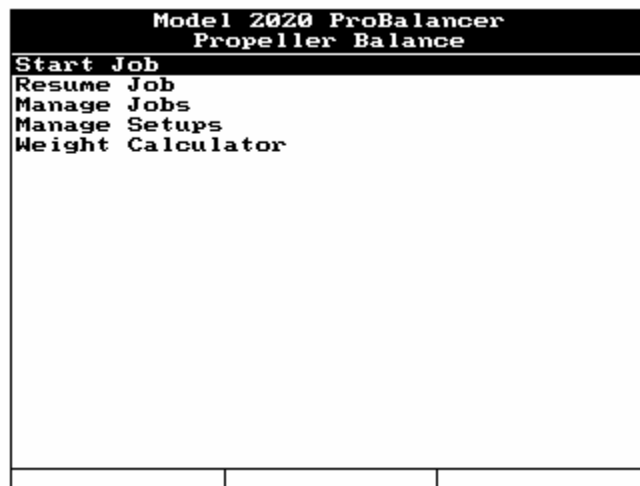

5. If the ATR-42 is listed in the Setup List, select it using the [↓] key, press [ENTER] and go to step D.1 below. If the ATR-42 is not in the Setup List, press the [F1], “New” key and go to step 6 below.



6. Complete the Prop Balance Setup screen per the illustration screen below.

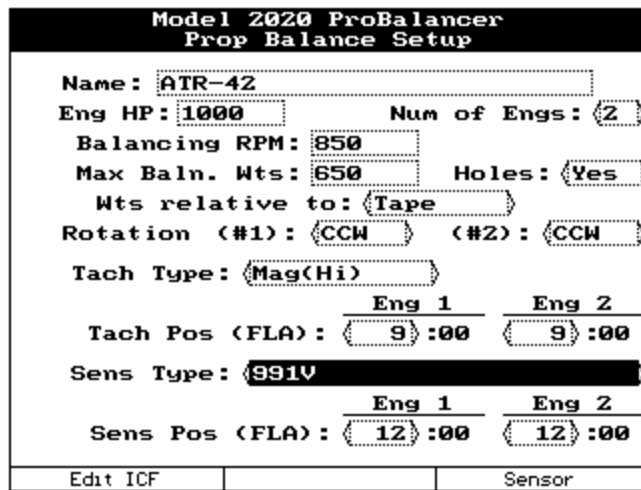

- 6.1. In the "Name:" field, use the analyzer keypad to enter "ATR-42". Press the [↓] key to move to the next field.
- 6.2. In the "Eng HP:" (Engine Horsepower) field, use the analyzer keypad to enter "1000". Press the [↓] key to move to the next field.
- 6.3. In the "Num of Eng:" field, press the [⇒] key until the field reads "2". Press the [↓] key to move to the next field.
- 6.4. In the "Balancing RPM:" use the analyzer keypad to enter "850". Press the [↓] key to move to the next field.



- 6.5. In the “Max Baln. Wts:” field, use the analyzer keypad to enter “650” the maximum total weight allowed for balancing on the propeller. You will enter a maximum amount per hole in another screen. Press the [↓] key to move to the next field.
 - 6.6. In the “Holes:” field, press the [⇒] key until the field reads “Yes” to indicate there are pre existing holes where balance weights are added that must be defined. Press the [↓] key to move to the next field.
 - 6.7. In the “Wts relative to:” field, press the [⇒] key until the field reads “Tape”. This indicates the angle to each of the holes is measured relative to the position of the reflective tape on the propeller, which is used as an index point. Press the [↓] key to move to the next field.
 - 6.8. In the “Rotation (#1):” field, press the [⇒] key until the field reads “CCW” for counterclockwise. Press the [↓] key to move to the next field.
 - 6.9. In the “Tach Type:” field, press the [⇒] key until the field reads “Mag Hi”. Press the [↓] key to move to the next field.
 - 6.10. In the “Tach Pos” (FLA): field, press the [⇒] key until the field reads “9.00”. Press the [↓] key to move to the next field.
 - 6.11. In the “Sens Type:” field, press the [⇒] key until the field reads “991V”. Press the [↓] key to move to the next field.
 - 6.12. In the “Sens Pos: (FLA) field, press the [↓] key until the field reads “12:00”. This indicates the mounted axis relative to the prop shaft. Press the [F1] “Edit ICF” key to continue.
7. The Edit ICF screen shown below will be displayed. Use the analyzer keypad to enter the “g/IPS, Deg/Rotation and Samples as shown below for the ATR-42. When all fields are complete, press [ENTER] to accept and continue.

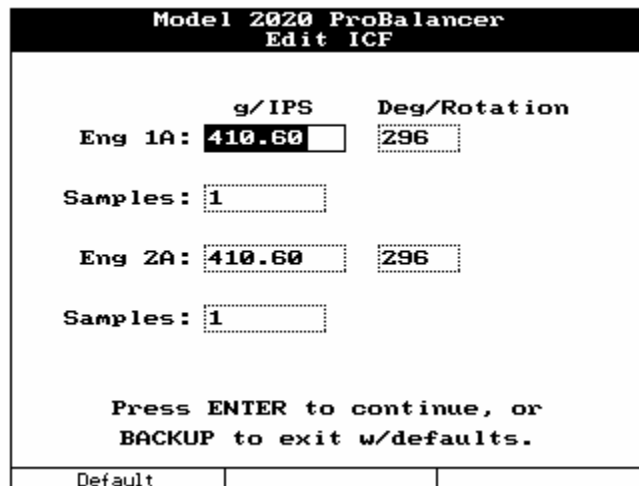

8. The screen will return to the Prop Balance Setup screen shown in Step 6 above. From that screen, press [ENTER] to continue.

9. The “Prop Hole Layout Setup” screen will be displayed as illustrated in the screen below.
 - 9.1. The “Name:” field will automatically be filled in from the previous screen above or you may enter a name of your choice with the analyzer keypad.
 - 9.2. Press the [↓] key to move to the “No. of Holes:” field. Use the analyzer keypad to enter “28” in the field. Press the [↓] key to move to the next field.

Model 2020 ProBalancer Prop Hole Layout Setup							
Name : ATR-42		No. of Holes : 28		Space : Uneven			
Dir (FLA) : CCW		Max H. Wt : 65					
Ang	#	Ang	#	Ang	#	Ang	#
30	28	135	19	240	10	345	1
37	27	142	18	247	9		
45	26	150	17	255	8		
52	25	157	16	300	7		
60	24	165	15	307	6		
67	23	210	14	315	5		
75	22	217	13	322	4		
120	21	225	12	330	3		
127	20	232	11	337	2		

- 9.3. In the Space field, use the [⇒] key to toggle the answer to “Uneven”. Press the [↓] key to move to the next field.
 - 9.4. In the “Dir (FLA):” field, press the right arrow key until the field reads “CCW” for counterclockwise. This is the direction of the hole numbering sequence for the installation. This direction is independent of the method used to determine the location of hole #1 in Step 9.6 below. Press the [↓] key to move to the next field.
 - 9.5. In the “Max H. Wt:” (Maximum Hole Weight) field, use the analyzer keypad to enter “65”. Press the [↓] key to move to the next field
 - 9.6. In the “Ang” field, use the keypad to enter the angle of the default “#” number shown in the adjacent field. The default will be in order from 1 to 28. The #1 hole is located at 345 degrees, measured in a clockwise direction as viewed from the front, relative to the tachometer trigger. Check that each angle (Ang) matches the respective hole number (#) as shown in the screen above EXACTLY. When complete, press the [ENTER] key to accept and continue.
10. The screen will displayed the question “Store this new setup?” Press the [F1] “Yes” key to store the setup.

D. Data Acquisition

1. The Customer Information Screen will be displayed. Use the analyzer keypad to enter a customer name in the “Name:” field. The analyzer will maintain a list of customer names as new names are entered. If names have been previously entered into this analyzer, you may press the [F1] “Names” key and select a customers name from the provided list. Press the [↓]

key to move to the next field and use the analyzer keypad to enter the optional aircraft registration and aircraft total time as required. When all fields are complete, press the [ENTER] key to accept and continue.

2. The next screen to be displayed is the Engine Information screen. While all these fields are optional, we highly recommend you fill in as much information as possible to provide better record keeping and search functions in AvTrend. Use the key pad and the arrow keys to complete the fields for the engine. S/N = Serial Number. In the serial number field, you may press the [F1] “Serial Nos” key to select the serial number from a list if this number has previously been entered in this analyzer. Type = Type engine or prop. Pos = position (1 or 2). TSO = Time since overhaul and TSN = Time since new. All fields are filled in using the analyzer keypad except the Pos: field which is selected using the [⇒] key. When all fields are complete, press the [ENTER] key to continue.
3. The next screen to be displayed will be the Prop Balance Equipment Setup screen. This screen gives instructions on installing sensors and cables. You may also check the Phototach alignment by pressing the [F1] “Tach Pwr” key which supplies power to the optical tachometer for checking alignment with the reflective tape.
4. The “Start Aircraft” screen will be displayed with instruction to “Remove all trim weights”. Remove all previously installed trim balance weights from all hole locations to begin the balance with a clean slate. When you have verified that all weights are removed, press the [ENTER] key to continue.
5. The analyzer will display the Engine 1, Run 1 screen. Chapter 20 of the Model 4040 User’s Manual gives detailed instructions on how to read the converging scale if you are not familiar with it. Increase RPM on the engine to a low cruise setting and allow the analyzer to collect data for approximately 10 to 15 seconds. The “Err: indication at the bottom of the text portion of the screen should be as steady as possible with very little change before you press [ENTER] to stop acquisition. If the Err is not “0”, this is not an indication of failure or fault, only that the vibration averaging errors cannot be resolved below the displayed level. This Err value will typically be higher as the balancing process reduces the vibration amplitude.
6. After pressing [ENTER] the review screen will be displayed. This is the amplitude and phase angle reading for the engine. You may retake the data by pressing the [F1] “Retake #1” function key as indicated at the bottom of the screen. When satisfied with the acquired data, press the [ENTER] key to accept and continue.
7. The “Shutdown Aircraft” instruction screen will be displayed. Shut down the engine using normal shutdown procedures. When all shutdown tasks are complete, press the [F3] “Continue” key.
8. The Prop Suggested and Installed Weights screen will be displayed. At the top of the screen you will see the Run number. The left side of the screen shows the Suggested weight installation by actual weight and phase angle. Directly below the raw solution you will see a specific weight (in grams) in the left column and a corresponding hole number(s) in the right column where that weight should be installed. The Installed column at the right side of the screen is where you must enter the actual weight and hole number(s) where that weight was installed. Be as accurate as possible with the installed weight as the analyzer will use this information to calculate the follow on influence for the next solution (if required). Notice at the bottom of the screen the instructions: “Remove old, install & enter new weight.” This means that ALL previously installed weights must be removed with each new weight installation. At the bottom of the screen, the three function keys are defined as: [F1],

Inst=Sugg, press this key to default the Installed columns to the values displayed in the Suggested column. [F2], Inst=None, press this key to zero out all weight in the Installed column. [F3], Quit Job, press this key if you are satisfied with the current vibration levels and wish to terminate the balance job, leaving the previously installed weights in place. After the screen is complete per your actions, press the [ENTER] key to continue.

9. If you chose to continue the job, the “Start Aircraft” screen will be displayed indicating you are ready to start the engine for the next run. Steps 4 through 8 will be repeated until the vibration amplitude has been reduced to a satisfactory level, usually three runs total.

E. Quit Job

1. If you selected [F3] “Quit Job” in step 8 above you will be presented with the following confirmation screen. If you are certain you want to end the job press [F1] “Yes” and the job will be marked as completed. This choice will generate the message in step 2 below. Choosing [F2] “No” will take you back to the job in progress.

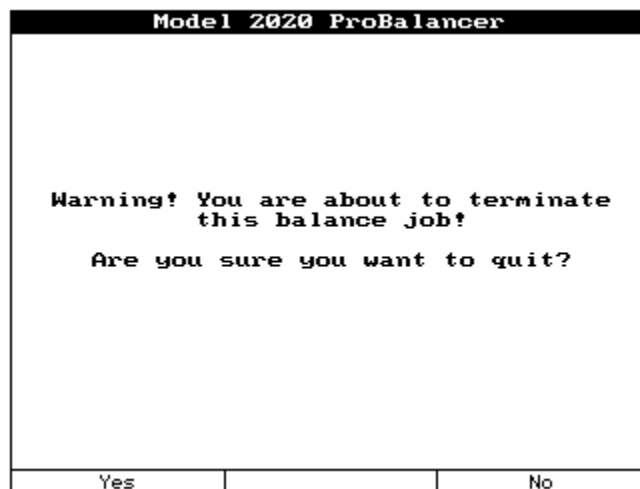

2. Selecting [F1] “Yes” from the screen shown in step 1 above will cause the Update ICF screen to be displayed. Press [F1] “Yes” if the job went as expected. It is possible to update and store the calculated ICF in the setup. This allows you to refine the ICF and potentially reduce the number of runs required in future jobs using this same setup. Select [F2] “No” if the balance job did not go as expected. This will keep mistakes or poor mechanical condition from influencing the setup causing unnecessary runs when using the same setup in the future.
3. Remove all test equipment and return aircraft to airworthy condition. Insure only permanent weights are mounted on the propeller and that they are mounted in accordance with the manufacturer’s instructions or the *ACES Guide to Propeller Balance* as applicable.