



Application Note

Agusta Westland AW139

Main Rotor Track and Balance

Part Number: 11-200-0268

AppNote Number: A-AGAW139-2020-MR (Rev. 5.0, Aug 2009)

This Application Note is provided for information only and does not supersede the requirements or guidelines set forth in the applicable engine or airframe maintenance manual. Technology for Energy Corporation assumes no obligation or liability, either expressed or implied, to the Purchaser arising out of the use of this procedure.

Copyright © 2009, TEC Aviation Division. All rights reserved. This document is to be printed and reproduced for personal use only.



Application Note

Application Note Number	A-AGAW139-2020-MR
Revision	5.0 (From Airframe information obtained 6/2009)
Function	Main Rotor Track and Balance
Airframe	Agusta Westland AW139
Engine	N/A
E-Setup Number	a-agaw139-2020-mr.asf
ACES Systems Analyzer	Model 2020 Series with EPS
Boot/App Version	5.xx/5.xx or later
Procedure	N/A

Introduction

This Application Note covers the required equipment, equipment installation, analyzer setup, data acquisition and solution process for using the ACES Systems Model 2020 with the Main Rotor Enhanced Performance Software (EPS) option to perform main rotor track and balance on the Agusta Westland AW139. General instructions for the use of the Model 2020 can be found in the Model 2020 User Manual #2020-OM-01 (P/N 75-900-2020), Enhanced Performance Software Operational Supplement #2020-OM-01 Supplement 1 (P/N 75-900-2022), and Optical Tracker Operational Supplement #540-OM-1 (P/N 75-900-2021). All procedures for track and balance and all adjustments should be made in accordance with the Airframe Maintenance Manual.

A. Required Equipment

The following equipment is required to perform a Main Rotor Track and Balance*:

Item	Quantity	Description	Part Number
1.	1	Analyzer, Model 2020HR	10-100-2020HR
2.	2	Sensor, Vibe, Accel, 991D-1	69-100-0075
3.	1	Cable, Sensor 991D-1, 25'	10-320-0162
4.	1	Cable, Sensor 991D-1, 50'	10-320-0163
5.	1	Tracker, Optical, Model 540-2	75-900-0542
6.	1	Option, 2020 Enhanced Main Rotor	11-900-0003**
7.	1	Mount, Triaxial Sensor – 1/4"	22-430-0109
8.	1	Cable, Magnetic Pickup	10-320-0335

*This listing shows the latest design parts. It is acceptable to perform this task using previous designs with the appropriate accessories. For compatibility issues, contact ACES Systems.



**Using the Enhanced Main Rotor Option will require entries on screens not found in the standard 2020 software. If your 2020 does not display all of the following screens, contact ACES Systems to learn about the benefits and availability of EPS.

Optional Equipment

The following equipment may be used as an alternate when accomplishing the job:

Item	Quantity	Description	Part Number
9.	1	Target Assy, Tip	As Required
10.	1	Cable, Interf. Assy, Strobe	10-320-0161
11.	1	Strobelight	As Required
12.	1	Sensor, Magnetic Passive Speed	75-900-0187
13.	1	Cable, Magnetic Pick-Up, 25'	10-320-0052

Miscellaneous Equipment

Tape or tie wraps to secure cables to airframe.

If adjustments are to be made to the main rotor balance, use only hardware or balance weights that are specified in the applicable airframe maintenance manual.

B. Equipment Installation

- Place the analyzer ([Item 1](#)) in the flight compartment.
- The magnetic pickup and interrupter are permanently installed on the aircraft. If not, install Magnetic Pickup ([Item 12](#)) on swashplate and secure. ([Figure 1 Detail A](#)) Rotate the Main Rotor until the magnetic pickup and interrupter are aligned and the rotor is in the position shown in [Figure 2](#). The blade over the nose of the aircraft will become “ACES 1” for balancing. The static location of this blade determines the “Aiming Point” for track acquisition. The remaining blades will be identified as, “ACES 2”, “ACES 3”, “ACES 4” and “ACES 5”, in passing order as shown below.
- Install Sensor Mount ([Item 7](#)) on the floor behind the pilot’s seat. Install the Axial/Vertical Vibration Sensor ([Item 2](#)) with the electrical connector facing up. Install the Radial/Lateral Vibration Sensor ([Item 2](#)) with the electrical connector facing to the right. ([Figure 3](#))

NOTE

Secure and route cables as not to interfere with hot or rotating components and aircraft controls. Insure there is adequate slack in the cables to allow full cyclic and collective inputs.

- Install the Tach Cable as follows:
 - If the magnetic pickup is not permanently installed or the maintenance connector does not provide a Tach signal, connect the “MAG PICK-UP” end of the Tach Cable ([Item 13](#)) to the Mag Pickup and safely route the cable into the cabin area. Connect the end marked “ANALYZER” to the “TACH 1” connector. ([Figure 1 Detail A](#))

- 4.2 Install the Adapter Cable (Item 8) into the outlet located behind the center pedestal. Safely route the cable to the analyzer. Connect the Analyzer end of the Cable to the “TACH 1” connector. (Figure 1 Detail B)
5. Install Vertical Vibe Sensor Cable (Item 3) to the Sensor connector that is point up. Route the Cable safely to the Analyzer. Connect the Analyzer end of the Cable to the “CHANNEL A” connector.
6. Install Lateral Vibe Sensor Cable (Item 4) to the Sensor connector facing right. Route the Cable safely to the Analyzer. Connect the Analyzer end of the Cable to the “CHANNEL B” connector.
7. Connect the Optical Tracker (Item 5) to the Aux./Comm port on the Analyzer.
8. Reinstall any previously removed cowlings. Return aircraft to flying configuration.

Equipment Installation Diagram

Figure 1

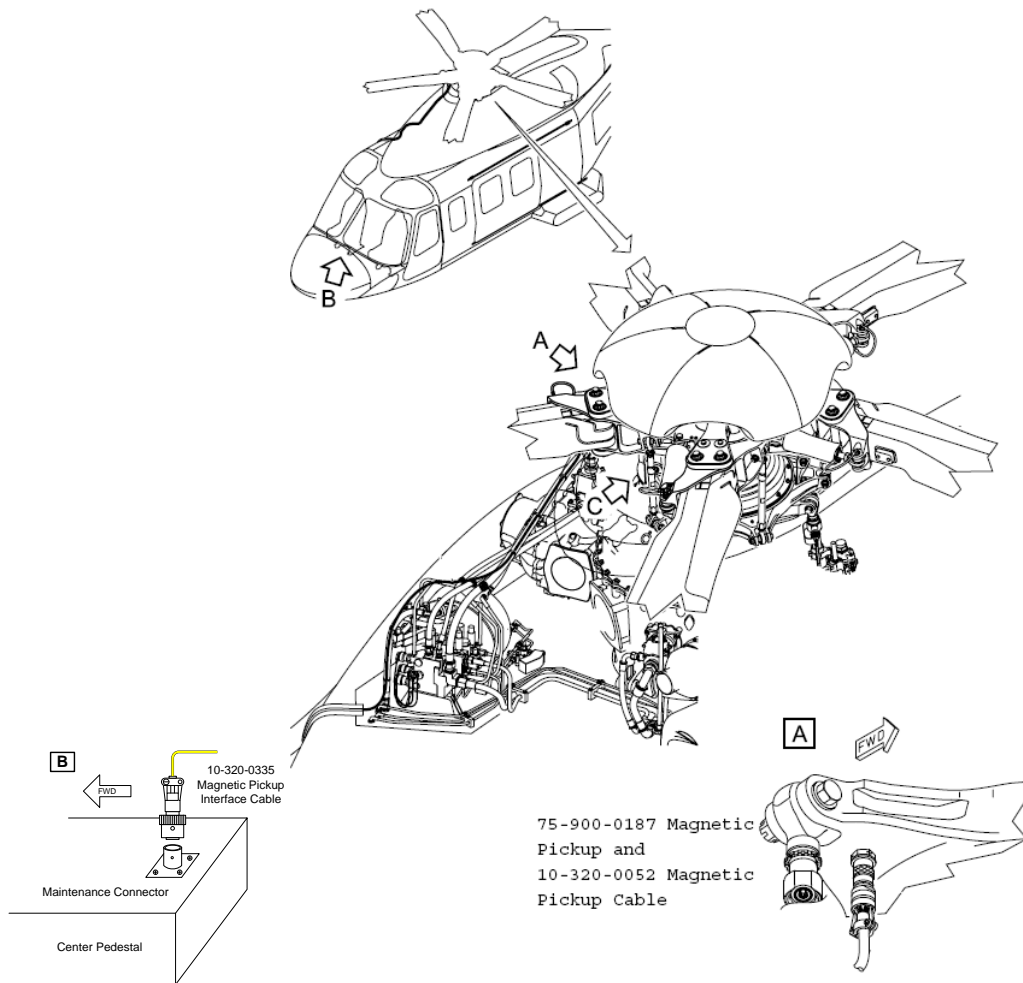

Figure 2

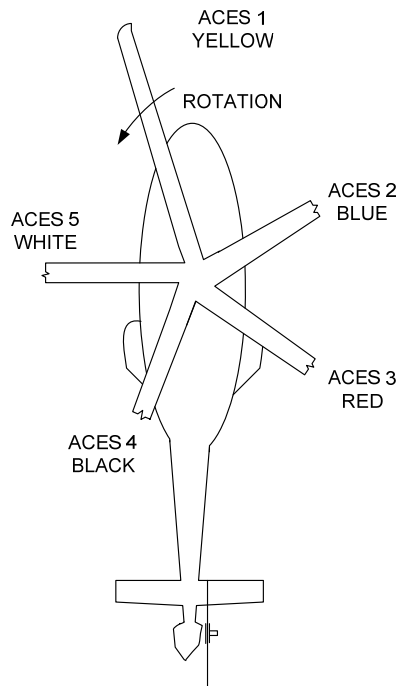
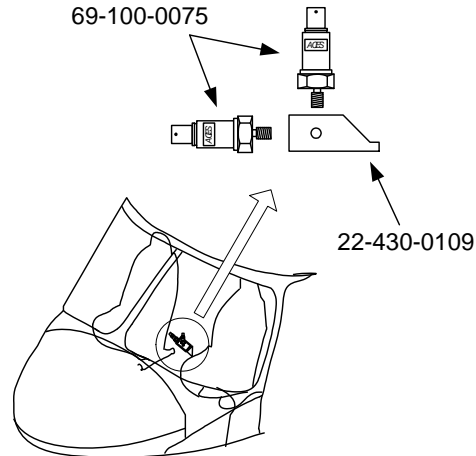

Figure 3



C. Analyzer Set Up

1. Insure the analyzer battery is charged prior to starting the job. See the Model 2020 User Manual #2020-OM-01 (P/N 75-900-2020) Chapter 2 for detailed instructions on battery charging.
2. Turn the analyzer ON by pressing the [ON/OFF] key.
3. From the Main Menu shown below, select “Main Rotor Track & Balance” and press the [ENTER] key.

Select Setup List	
1)	a-agaw139-2020-mr
2)	BRAND X HELICOPTER
3)	BRAND Y HELICOPTER
4)	BRAND Z HELICOPTER
New	

6. The “Main Rotor Setup” screen now appears. Enter the Main Rotor Setup as shown below. You can enter any name that is convenient for locating the setup in the future. When completed press [ENTER].

Model 2020 ProBalancer Main Rotor Setup			
Name:	a-agaw139-2020-mr		
Vertical Chan:	A		
Lateral Chan:	B		
Sensor:	991D-1		
Tach Type:	Mag(Hi)		
Tach Chan:	1	WtPos:	5
Blades:	5	Relative to:	Avg
RPM:	297	Trk Units:	mm
<< Conditions >>			
MPOG	Both	Hover	Both
80 KTS	Both	120KTS	Both
Vh	Both		Both

7. The “Tracking Setup” screen will be displayed next. Enter the values as shown in the illustration below. Press [ENTER] to continue.

**Model 2020 ProBalancer
Tracking Setup**

Rotor Diameter:

Lead/Lag Units:

8. The “Main Rotor Conds. Setup” screen will appear next as displayed below. The “limit” field under each measurement type will set the point at which the analyzer will determine whether corrections are needed. This is not reflective of a limit imposed by the manufacturer. See the applicable Maintenance Manual for the track and vibration levels required for return to service. Enter the information as indicated in the illustration below. Press [ENTER] to continue.

**Model 2020 ProBalancer
Main Rotor Conds. Setup**

Conds.	Vert Chart ID	Lat Chart ID	Track Adj. ID
MPOG	0	1	1
Hover	1	1	0
80 KTS	1	0	0
120KTS	2	0	0
Vh	3	0	0
Limit	0.15	0.15	10.00

Enter ID=0 if no adjustment.
Diff charts use diff IDs.

9. The next screen to appear will be the “M/R Adj Symbol Setup” screen. The function of this screen is to determine the direction of movement for a positive (+) adjustment. In this application, a positive move indication means to ADD weight, sweep a blade FWD, and move the blade UP with both Pitch Change Link (BLADE) and Trim Tab (TAB). Enter the values as shown below. When completed press [ENTER]. Next, the balance charts will be entered into the analyzer.

```

Model 2020 ProBalancer
M/R Adj Symbol Setup

Adjustment
Positive Value Meaning

Weight:  ADD
Sweep:   FWD
Blade:   UP
TAB:     UP
    
```

10. The first balance chart to define will be the “Vert: Hover – 80 KTS” chart. Enter the information as presented below. Press [ENTER] to continue.

```

Model 2020 ProBalancer
Main Rotor Chart Setup

Name:  Vert:Hover-80 KTS
Chart Type: Regular
Sweep Only: No
Adj. Unit: MRK
Adj./IPS: 20.00

Bld/Pos      Adj @      Bld/Pos
-----
ACES 1       11 :00       ACES 5
ACES 2        8 :20
ACES 3
ACES 4

Bld/Pos: in CW or CCW order
+Adj = WtAdd/SwFwd/BlUp/TabUp

Help
    
```

11. The second chart to define will be the “Vert: 120KTS” chart. Enter the information as shown below and press [ENTER] to continue.

Model 2020 ProBalancer Main Rotor Chart Setup		
Name: <input type="text" value="Vert:120KTS"/>		
Chart Type: <input type="text" value="Regular"/>		
Sweep Only: <input type="text" value="No"/>		
Adj. Unit: <input type="text" value="DEG"/>		
Adj./IPS: <input type="text" value="30.00"/>		
Bld/Pos	Adj @	Bld/Pos
<input type="text" value="ACES 1"/>	<input type="text" value="8"/> : <input type="text" value="40"/>	<input type="text" value="ACES 5"/>
<input type="text" value="ACES 2"/>	<input type="text" value="6"/> : <input type="text" value="20"/>	
<input type="text" value="ACES 3"/>		
<input type="text" value="ACES 4"/>		
Bld/Pos: in CW or CCW order		
+Adj = WtAdd/SwFwd/BlUp/TabUp		
Help		

12. The third chart to define will be the “Vert: Vh” chart. Enter the information as shown below and press [ENTER] to continue.

Model 2020 ProBalancer Main Rotor Chart Setup		
Name: <input type="text" value="Vert:Vh"/>		
Chart Type: <input type="text" value="Regular"/>		
Sweep Only: <input type="text" value="No"/>		
Adj. Unit: <input type="text" value="DEG"/>		
Adj./IPS: <input type="text" value="30.00"/>		
Bld/Pos	Adj @	Bld/Pos
<input type="text" value="ACES 1"/>	<input type="text" value="8"/> : <input type="text" value="40"/>	<input type="text" value="ACES 5"/>
<input type="text" value="ACES 2"/>	<input type="text" value="6"/> : <input type="text" value="20"/>	
<input type="text" value="ACES 3"/>		
<input type="text" value="ACES 4"/>		
Bld/Pos: in CW or CCW order		
+Adj = WtAdd/SwFwd/BlUp/TabUp		
Help		

13. The fourth chart to define will be the “Lat: MPOG-Hover” chart. Enter the information as shown below and press [ENTER] to continue. MPOG stands for Minimum Pitch On Ground – this will be 100% NR flat pitch or as defined in the current Maintenance Manual.

Model 2020 ProBalancer Main Rotor Chart Setup		
Name:	Lat:MPOG-Hover	
Chart Type:	Regular	
Sweep Only:	No	
Adj. Unit:	GMS	
Adj./IPS:	1000.00	
Bld/Pos	Adj @	Bld/Pos
ACES 1	11 :00	ACES 5
ACES 2	8 :20	
ACES 3		
ACES 4		
Bld/Pos: in CW or CCW order		
+Adj = WtAdd/SwFwd/BlUp/TabUp		
Help		

14. Finally, the “Tracking Influence Setup” screen data will be entered as shown below. When completed, press [ENTER] to continue.

Model 2020 ProBalancer Tracking Influence Setup			
Conds	AdjName	Unit	Adj/mm
MPOG	PCL	MRK	0.142
+Adj = WtAdd/SwFwd/BlUp/TabUp			

D. Data Acquisition

- The “Customer Information” screen will be displayed, as shown below. Use the analyzer keypad to enter a customer name in the “Name:” field. The analyzer will maintain a list of customer names as new names are entered. If names have been previously entered into this analyzer, you may press the [F1] “Names” key and select a customers name from the provided list. Press the [↓] key to move to the next field and use the analyzer keypad to enter the optional aircraft registration and aircraft total time as required. When all fields are complete, press the [ENTER] key to accept and continue.

Model 2020 ProBalancer Customer Information		
Enter the following optional Customer Information.		
Name: CUSTOMER NAME		
A/C Registration: N1234		
A/C Total Time: 123.4		
Press ENTER to continue.		
Names		

- The next screen to be displayed is the “Tracking Selections”, as shown below. Complete the first two fields as shown below. Then, rotate the Main Rotor head so that the Magnetic Pickup and Interrupter align (Figure 2). Measure the distance from the location where the Optical Tracker will be held to the tip of the “ACES 1” blade. Enter the distance, in inches, into the “Inches To Bld Tip” field. When all fields are complete, press the [ENTER] key to continue.

Model 2020 ProBalancer Tracking Selections		
Track Device: Tracker		
- For Optical Tracking Only -		
Number of Rotations: 20		
Inches To Bld Tip: 178		

- The next screen to be displayed will be the “Connect Sensors” screen as illustrated below. This screen gives instructions on installing sensors and cables. The [F1] “Tach Pwr” key is used to provide Tach power for checking alignment with the reflective tape and is not used in this application. Power will be provided as necessary when the [ENTER] key is pressed.

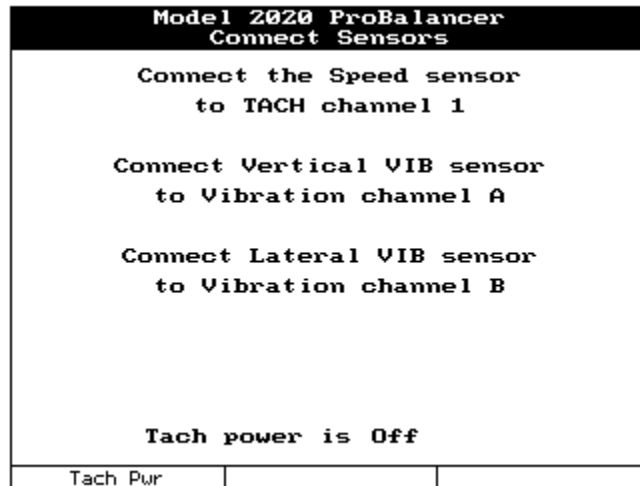

4. The “Start Aircraft” screen will be displayed with instructions to “Start Aircraft per Flight Manual”. When the aircraft is started and normal operating conditions have been established, press the [ENTER] key to continue.

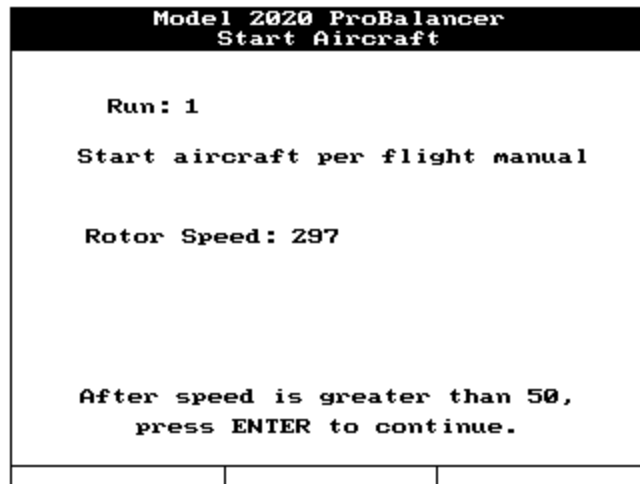

5. The analyzer will display the “Select Aircraft Condition” screen as displayed below. Select the condition that you want to gather data for using the [↑] [↓] arrows and press [ENTER]. Pressing [F3] “Chk Track” will allow you to view the track picture but will not save the reading as part of the highlighted condition. See [Paragraph 7 below](#) to record the track picture with the condition’s vibration readings.



- The analyzer will present the data acquisition screen as shown below. This screen allows you to monitor both the current and averaged vibration readings. Operate the aircraft in the configuration for the selected condition and allow the analyzer to collect data. While monitoring the measurement, you may press the [F1] “Reset” key to restart the averaging process. Use this feature as a way to validate the quality of the measurement. If the averaged readings return to a value similar to the displayed value prior to being “Reset”, the measurement can be considered good. If the measurement is not similar, you may choose to “Reset” the average again. If the “Err” (Error) at the bottom of the text portion of the screen is not “0”, this is not an indication of failure or fault, only that the vibration averaging errors cannot be resolved below the displayed level. This “Err” value will typically be higher as the balancing process reduces the vibration amplitude. The “Err” indication should be as steady as possible with very little change before you press the [ENTER] key to stop acquisition.

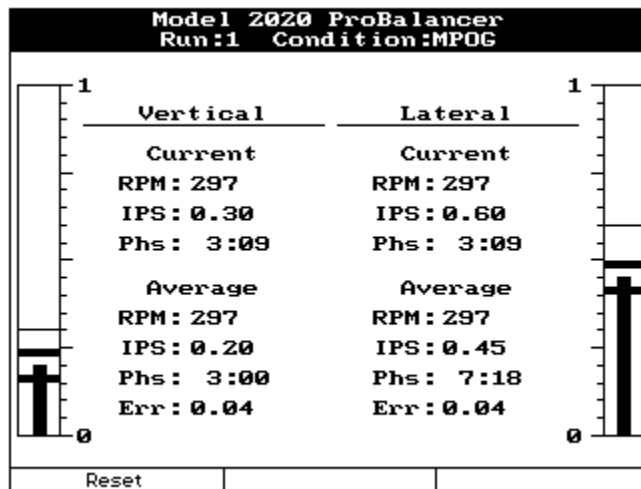

See the Model 2020 User Manual #2020-OM-01 (P/N 75-900-2020) Chapter 16 for detailed instructions on how to read the “Converging Vibration Indicator and Scale”.

- The “Review Vibe Data” screen will be displayed as shown in the example below. These are the amplitude and clock angle readings for the condition. You may retake the data by

pressing the [F1] “Retake” function key as indicated at the bottom of the screen. When satisfied with the acquired data as displayed, press the [ENTER] key to accept the data with “No” track information and continue. To record the track picture for the condition, press [F3] “Track” and proceed to [Paragraph 8 below](#).

Model 2020 ProBalancer Review Vib Data	
Run: 1	
Condition: MPOG	
Vertical: 0.20	IPS @ 3:00
Lateral: 0.45	IPS @ 7:18
Track Data: No	
Press F1 to retake data.	
Press F3 to take track data.	
Press ENTER to continue.	
Retake	Track

8. The “Aim and fire tracker” screen will be displayed as shown in the example below. Aim the tracker at the point in space that will lead the “ACES 1” blade when the Magnetic Pickup and interrupter are aligned. (See Section B [Figure 2](#) above) Raise the tracker smoothly towards the rotating rotor disk while observing the LEDs on the back of the tracker.

<p>Aim and fire tracker</p> <p>Press key to abort</p>

- 8.1 Raise the tracker until the three green LED lights are illuminated.
- 8.2 Raise the tracker further to verify the upper set of three red LEDs illuminate. Illumination of the three upper LEDs verifies there is enough contrast to operate the tracker. If the upper set of red LEDs does not illuminate, there is not enough contrast for the tracker to operate properly.
- 8.3 If sufficient contrast is verified, slowly lower the tracker to a point where the center green LED is illuminated. Hold the tracker steady in this position.

- 8.4 To activate the tracker, press and release the trigger one time. It is not necessary to hold the trigger down. Continue to hold the tracker steady (green lights illuminated) while acquiring data. The amber light will pulsate during data acquisition.
- 8.5 When the amber light extinguishes, data acquisition is complete and you may lower the tracker.
9. The track picture will be displayed on the “Check Track – Results” screen. Lead/lag readings will be displayed at the top of the screen. A negative number (-) indicates a “Lead” condition as this blade is the indicated measurement less than the average interval. A positive number (no sign) indicates a “Lag” condition as this blade is the indicated measurement more than the average interval. Readings will be displayed graphically in the center of the screen. Lead readings will be indicated to the Left of the average interval marking vertical line. Lag readings will be displayed to the Right of the line. Track readings will be displayed above or below the line relative to the average of all blades or in relation to the blade specified in the setup, [Paragraph C.6 above](#). The bottom of the screen will give a numeric reading of the blade track elevation. The bottom line will display the number of data samples gathered. If the total number of data samples gathered is less than 75% of the total number of samples requested the results are questionable and should be retaken. When you are happy with the quality of the data, press **[ENTER]** to continue.

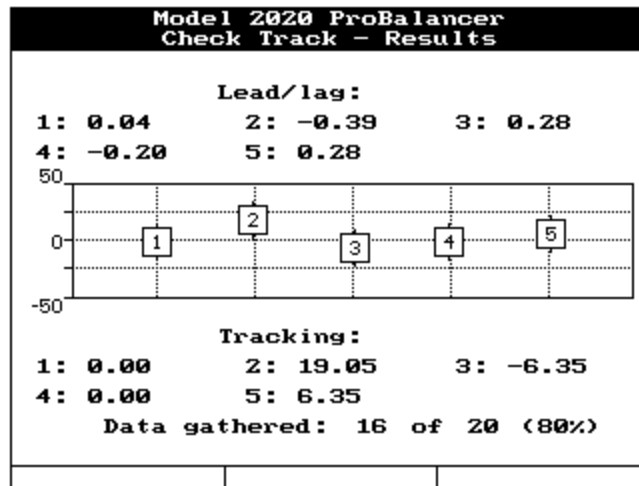

10. The “Review Vibe Data” screen will reappear as shown in the example below. This time the “Track Data” line will read “Yes” indicating that track data has been taken and stored in this condition. You may retake vibration data by pressing the **[F1]** “Retake” function key as indicated at the bottom of the screen. You may retake the track data by pressing the **[F3]** “Track” key. If you are satisfied with the current measurements, press **[ENTER]** to continue.

Model 2020 ProBalancer Review Vib Data		
Run: 1		
Condition: MPOG		
Vertical:	0.20	IPS @ 3:00
Lateral:	0.45	IPS @ 7:18
Track Data: Yes		
Press F1 to retake data.		
Press F3 to take track data.		
Press ENTER to continue.		
Retake		Track

11. The “Select Aircraft Condition” screen will reappear as shown in the example below. This time any condition that has stored vibration and/or track data will have an [x] preceding the condition name. Repeat sequence through all flight regimes. You can choose to “End Run” at any time by pressing the [F1] “End Run” key. This sequence will allow you to review all previous measurements before proceeding to the suggested solutions. If a condition has recorded a vibration or track reading that is in excess of the limits defined in [Paragraph C.8 above](#), the word “Adjust” will appear above the [F2] key. Pressing [F2] “Adjust” will bypass the review process and move directly to the suggested solution screens. In either case you will be taken to [Paragraph 12 below](#).

Model 2020 ProBalancer Select Aircraft Condition		
[x]	MPOG	
[]	Hover	
[]	80 KTS	
[]	120KTS	
[]	Vh	
End Run	Adjust	Chk Track

NOTE

The [F1] “End Run” and [F2] “Adjust” keys are the only ways to exit this screen. Pressing [ENTER] will restart the data collection process for the highlighted condition.

12. The analyzer will display the “Shut Down Aircraft” screen as shown below. When this process is complete, press the [F3] “Continue” key to review the data or view the suggested solutions.

**NOTE**

It is important to remember that when installing or removing weights and recording their positions the influence used for the next run will be updated by the result from the previous run's solution. Therefore, be as accurate as possible when recording adjustments made regardless whether the recommended solution is implemented. The only entries on these screens should reflect the actual solution implemented.

13. The analyzer will present all of the solutions possible from the data gathered. It is possible for the analyzer to give two adjustments that would adversely affect the other. The user is ultimately responsible for determining which adjustments to implement and which to discard. If a suggested correction is determined unnecessary, use "Inst=None" [F2] to eliminate data in the "Installed" column. Make the desired adjustments to the rotor system as called for by analyzer and press [ENTER]. The user will now be prompted to start the engine and continue with Run #2.

E. Solution Examples

This section contains samples of the solution screens possibly encountered during the job. The corrections are examples only and do not reflect actual aircraft data. The actual solution screens encountered by the user will vary depending upon data acquired.

CAUTION

At no point should a correction be made that contradicts information in the maintenance manual.

The analyzer will attempt to resolve the vibration and/or track level to 0.00. This may require adjustments that are not practical to duplicate. The technician must determine the closest possible match to the suggestion.

NOTE

Solutions will only be presented for readings that exceed the limits set in [Paragraph C.8 above](#). It is necessary to add the closest measurable amount of correction and record the actual correction in the "Installed" column.

The Model 2020 analyzer can only update internal Influence Coefficients when one solution per run

is implemented. Even though multiple solution screens are presented, entering solutions from multiple screens on the same run will disable the Influence Coefficient Update during the job.

1. Refer to the Maintenance Manual for the correct sequence when making adjustments to the Main Rotor.
2. The first possible solution screen is the “Vert: Hover-80 KTS, MRK” solution. This screen will suggest Pitch Change Link adjustments in Marks based on the measured vertical vibration readings in a Hover and at 80 KTS.

In the example below, it is suggested to adjust the “ACES 4” Pitch Change Link (PCL) up 3.80 Marks (MRK) and the “ACES 5” PCL up 5.62 MRK. The closest full MRK adjustment was 4.00 MRK up on the “ACES 4” and 6.00 MRK up on the “ACES 5”. This adjustment was made and entered into the Analyzer.

Model 2020 ProBalancer M/R Sugg. and Inst. Adj		
Run 2		
Name: Vert:Hover-80 KTS, MRK		
Bld/Pos	Suggested	Installed
ACES 1	0.00	0.00
ACES 2	0.00	0.00
ACES 3	0.00	0.00
ACES 4	3.80	4.00
ACES 5	5.62	6.00
+Adj = WtAdd/SwFwd/BlUp/TabUp		
Inst=Sugg	Inst=None	Quit Job

3. The second possible solution screen available is from the “Vert: 120KTS, DEG” chart. This screen suggests the outboard trim tab corrections to make to improve vertical vibration readings at 120KTS. In the example below, the suggestion is to add 2.89 Degrees (DEG) to the “ACES 1” blade and to add 1.11 DEG to the “ACES 5” blade. The closest measurable value was 3.00 DEG on the “ACES 1” blade and 1.00 DEG on the “ACES 5” blade. This move was made and entered into the Analyzer.

NOTE

Inboard and outboard tabs on the same blade must be bent in the same direction.

Model 2020 ProBalancer M/R Sugg. and Inst. Adj		
Run 3		
Name: Vert:120KTS, DEG		
Bld/Pos	Suggested	Installed
ACES 1	2.89	3.00
ACES 2	0.00	0.00
ACES 3	0.00	0.00
ACES 4	0.00	0.00
ACES 5	1.11	1.00
+Adj = WtAdd/SwFwd/BlUp/TabUp		
Inst=Sugg	Inst=None	Quit Job

4. The third possible solution screen available is from the “Vert: Vh, DEG” chart. This screen suggests the inboard trim tab corrections to make to improve vertical vibration readings at 120KTS. In the example below, the suggestion is to add 2.89 Degrees (DEG) to the “ACES 1” blade and to add 1.11 DEG to the “ACES 5” blade. The closest measurable value was 3.00 DEG on the “ACES 1” blade and 1.00 DEG on the “ACES 5” blade. This move was made and entered into the Analyzer.

Model 2020 ProBalancer M/R Sugg. and Inst. Adj		
Run 4		
Name: Vert:Vh, DEG		
Bld/Pos	Suggested	Installed
ACES 1	2.89	3.00
ACES 2	0.00	0.00
ACES 3	0.00	0.00
ACES 4	0.00	0.00
ACES 5	1.11	1.00
+Adj = WtAdd/SwFwd/BlUp/TabUp		
Inst=Sugg	Inst=None	Quit Job

5. The fourth possible solution screen available is from the “Lat: MPOG -Hover, GMS” chart. This screen suggests the corrections to make to improve lateral vibration readings at MPOG and in a Hover. In the example below, the suggestion is to add 67.19 Grams (GMS) to the “ACES 2” blade and to add 194.97 GMS to the “ACES 3” blade. The closest measurable value was 67.00 GMS on the “ACES 2” blade and 195.00 GMS on the “ACES 3” blade. This move was made and entered into the Analyzer.

Model 2020 ProBalancer M/R Sugg. and Inst. Adj		
Run 1		
Name: Lat:MPOG-Hover, GMS		
Bld/Pos	Suggested	Installed
ACES 1	0.00	0.00
ACES 2	67.19	67.00
ACES 3	194.97	195.00
ACES 4	0.00	0.00
ACES 5	0.00	0.00
+Adj = WtAdd/SwFwd/BlUp/TabUp		
Inst=Sugg	Inst=None	Quit Job

6. The final possible solution comes from the “Tracking Influence Setup” screen. The Analyzer will present a suggested correction to the Pitch Change Link (PCL) in marks (MRK) to bring the track within limits. In this case, adjusting the “ACES 2” blade DOWN by (-)3.16 MRK should correct the track split. The closest full MRK adjustment is made and entered into the Analyzer. To enter a negative (-) number press the [SPACE] key once.

Model 2020 ProBalancer M/R Sugg. and Inst. Adj		
Run 1		
Name: Trk:MPOG, PCL,MRK		
Bld/Pos	Suggested	Installed
ACES 1	0.00	0.00
ACES 2	-3.16	-3.00
ACES 3	0.00	0.00
ACES 4	0.00	0.00
ACES 5	0.00	0.00
+Adj = WtAdd/SwFwd/BlUp/TabUp		
Inst=Sugg	Inst=None	Quit Job

F. Quit Job

- Repeat [Steps D.4](#) through [D.12](#) above applying the solutions as necessary. If all measurements in all conditions are below the limits set in [Paragraph C.8](#) above, the message below will appear. Pressing the [BACKUP] key will allow you to return to review the measurements from all runs. Pressing the [ENTER] key will allow you to take additional readings if you choose. Pressing [F3] “Quit Job” will mark the job as complete and take you to [Paragraph 2](#) below.

Model 2020 ProBalancer M/R Track & Balance		
<p>No solutions are recommended.</p> <p>Press BACKUP to view data. Press ENTER for next Run. Press F3 to quit job.</p>		
		Quit Job

2. From this screen, decide if you would like to update the ICF used in the original setup. Pressing **[F1]** “Yes” will add the chart corrections from this job to the ICF from the original setup. This can be a powerful tool when using this setup in the future. The chart corrections learned as a result of the previous job will be applied from the beginning of the next job that uses the same setup. This can reduce the number of runs required to balance the helicopter. If you select **[F3]** “No” any chart corrections applied during the previous job will be discarded. The setup will revert to the chart settings in place before the job was started. This can be useful if the helicopter didn’t respond as others of the same model or if a mistake was made somewhere during the job that caused extra runs to balance the helicopter.

Model 2020 ProBalancer Update Setup ICFs?		
<p>Do you want to update the setup's influence coefficients based on the result of this job?</p>		
Yes		No