



Application Note

Application Note Number	A-AGA119-2020E-MR
Revision	1
Function	Main Rotor Track and Balance
Airframe	Agusta A119 Koala
Engine	N/A
E-Setup Number	A-AGA119-2020E-MR.asf
ACES Systems Analyzer	Model 2020 w/Main Rotor Enhanced Software
Firmware Version	2.00 or greater
Procedure	N/A

Introduction

This Application Note covers the required equipment, equipment installation, analyzer setup, data acquisition and solution process for using the ACES Systems' Model 2020 with Enhanced Main Rotor Performance Software option to perform main rotor track and balance on the Agusta A119 helicopter. General instructions for the use of the Model 2020 can be found in user manual #2020OM-01. All procedures for track and balance and adjustments should be made in accordance with the A119 Maintenance Manual.

A. Required Equipment

The following ACES Systems' equipment is required.

Item	Quantity	Description	Part Number
1.	1	Model 2020 Analyzer	10-100-2020
2.	1	Optical Tracker Model 540-2	75-900-0542
3.	2	Sensor, Vibration, 991D-1	69-100-0075
4.	1	Cable, Sensor, 991D-1, 25'	10-320-0162
5.	1	Cable, Sensor, 991D-1, 50'	10-320-0163
6.	1	Mount, Vibe Sensor, .250 "L"	22-430-0035
7.	1	Mount, Vibe Sensor, 5/16 "L"	22-430-0036
8.	1	Cable, Adapter, Magnetic Pickup	10-320-0220

Miscellaneous Equipment

Copyright © 2000, TEC Aviation Division. All rights reserved. This document can be printed and reproduced for personal use only.

04/02/03

TEC Part Number 11-200-0116

Tape, tie wraps or cable clamps to secure cables to airframe.

B. Equipment Installation

Note:

Interrupter and magnetic pickup should be permanently installed on swashplate.

1. Install sensor bracket (P/N 22-430-0035) between the pilots and copilots seats and sensor bracket (P/N 22-430-0036) to upper left nut of the pilots inertia reel. Secure the first 991D-1 sensor (P/N 69-100-0075) to the bracket so that it is perpendicular to the longitudinal axis of the aircraft with connector pointing to the right. Install second 991D-1 sensor (P/N 69-100-0075) into bracket so that connector faces up.
2. Install sensor cables (P/N 10-320-0162 and 10-320-0163) to 991D-1 sensors and connect to 2020 analyzer. Connect vertical to channel A and lateral to channel B.
3. Connect magnetic pickup adapter cable (P/N 10-320-0220) to the signal socket located above and behind the pilots head. Connect other end of cable to tach channel 1.
4. Connect optical tracker (P/N 75-900-0542) to the Aux./Comm. port on the 2020 analyzer.

Equipment Installation Diagram

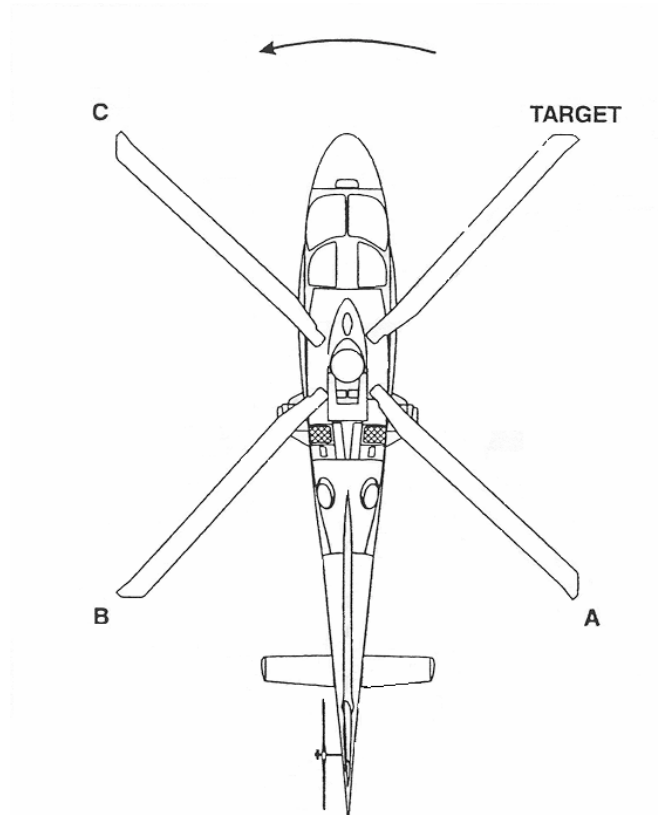
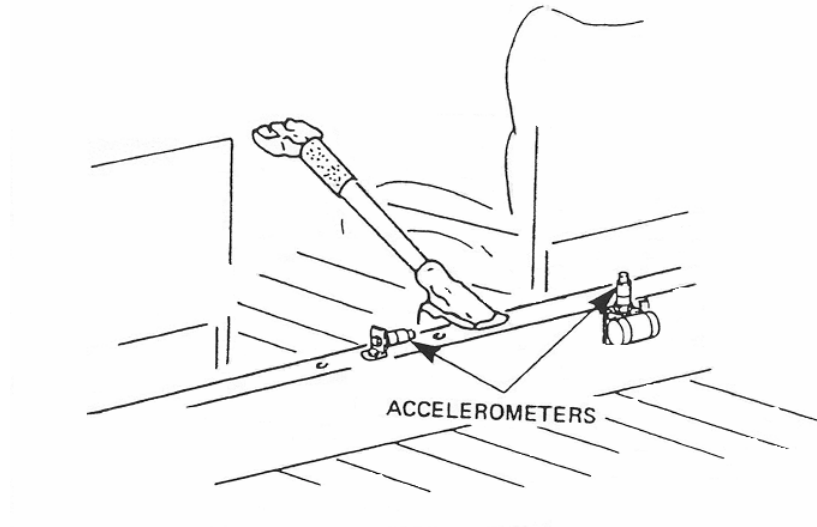

C. Analyzer Set Up

1. Turn the analyzer “ON”
2. Enter a new setup as follows; from the “Main Menu” select “Main Rotor Track and Balance” and press **[Enter]**. From the “Main Rotor Tack and Balance” menu, select **[Manage Setups]** and press **[Enter]**. From the ‘Manage Setups’ menu, select **[Edit]**and press **[Enter]**. From the “Edit Screen” press the **[New]** button.
3. The “Main Rotor Setup” screen now appears. Enter the main rotor job setup as shown. When completed press **[Enter]**.

Model 2020 ProBalancer
Main Rotor Setup

Name: AGUSTA A119
 Vertical Chan: (A)
 Lateral Chan: (E)
 Sensor: (991D-1)
 Tach Type: (Mag(H))
 Tach Chan: (1) WtPos: (4)
 Blades: (4) Relative to: (1)
 RPM: (385) Trk Units: (in)
 << Conditions >>
 Ground (Both) Hover (Both)
 80KTS (Both) 140KTS (Both)
 ONE (Both) (Both)

4. The “Main Rotor Conditions” screen will be charts to be used when calculating corrections for a given measurement. Chart “ID’s” of similar measurements with the same number will average the readings together for use in solutions. The “limit” field under each measurement type will set the point at which the analyzer will determine whether corrections are needed. Enter the information exactly as it appears in the appropriate fields. When completed, press **[Enter]**.

Model 2020 ProBalancer
Main Rotor Conds. Setup

Conds.	Vert Chart ID	Lat Chart ID	Track Adj. ID
Ground	0	1	1
Hover	0	0	1
80KTS	0	0	2
140KTS	0	0	2
ONE	0	0	2

Limit: 0.20 0.20 0.25
 Enter ID=0 if no adjustment.
 Diff charts use diff IDs.

5. The “M/R Adjustment Symbol Setup” screen is displayed next. The function of this screen is to determine the direction of movement for a + adjustment. Enter the values as shown. When complete press **[Enter]**.

Model 2020 ProBalancer
M/R Adj Symbol Setup

Adjustment
Positive Value Meaning

Weight: (ADD)
 Sweep: (FWD)
 Blade: (UP)
 TAB: (UP)

- The first main rotor chart to define will be the “Lateral”: Ground chart. This chart will determine the weight adjustments to perform for ground lateral vibration reduction. Enter the information exactly as it appears in the appropriate fields. When completed press **[Enter]**.

Model 2020 ProBalancer		
Main Rotor Chart Setup		
Name:	Lat:	Ground
Chart Type:	Regular	
Sweep Only:	No	
Adj. Unit:	GHS	
Adj./IPS:	500.00	
Bld/Pos	Adj @	Bld/Pos

TARGET	12:	0
A	9:	0
B		
C		
Bld/Pos: 1n CW or CCW order		
+Adj = WtAdd/SuFwd/BldUp/TabUp		
Help		

- Last, the “Tracking Influence Setup” screen will appear. This chart will determine the amount of pitch change adjustment required to improve track splits at ground and hover and tab bends required for in-flight track improvements. The “Adj./in.” sensitivity tells the balancer the amount of PCL and Tab adjustment required to equal one inch of movement at the blade tip. Enter the information exactly as it appears in the appropriate fields. When complete, press **[Enter]**

Model 2020 ProBalancer			
Tracking Influence Setup			
Conds	AdjName	Unit	Adj/in

Ground-Hover	PCL	Fit	4.00
80KTS-UNE	TAB	Deg	1.00
+Adj = WtAdd/SuFwd/BldUp/TabUp			

- Setup complete, press **[Enter]**, **[Backup]**, select “Start Job”, press **[Enter]** and then select the A119 Main Rotor Setup that was just created.

Select Setup List	
1 >	AGUSTA A119
2 >	SA341/342
3 >	AS365
4 >	HILLER UH-12
5 >	S-76
New	

D. Data Acquisition

1. Customer Information screen. It is recommended to complete this screen so that customer information will appear on printout assisting in identification of the job when it is stored in the analyzer memory. When finished press **[Enter]**.

Model 2020 ProBalancer Customer Information		
Enter the following optional Customer Information.		
Name:	CUSTOMER NAME	
A/C Registrations:	N12345	
A/C Total Time:	1228	
Press ENTER to continue.		
Names		

2. Tracking Selections screen. Allows the user to select tracking device for this particular job. Select Tracker or Strobex. If using optical tracker, enter the number of rotations desired and inches to blade tip. When complete, press **[Enter]**.

Model 2020 ProBalancer Tracking Selections		
Track Device:	Tracker	
- For Optical Tracking Only		
Number of Rotations:	50	
Inches To Blade Tip:	144	

3. Main Rotor Equipment Setup. Information screen that prompts the user to verify equipment installation has been performed in accordance with channel selections that were specified when building the setup. Press **[Enter]**.

Model 2020 ProBalancer Main Rotor Equipment Setup		
Install the speed sensor and connect to TACH Channel 1		
Install vertical vibration sensor to vibration channel A		
Install lateral vibration sensor to vibration channel B		
Tach power is off		
Tach On		

4. Start Aircraft screen. This screen allows the user to view the current main rotor rpm. When the aircraft has been started press **[Enter]**.

Model 2020 ProBalancer Start Aircraft		
Run:	1	
Start aircraft per flight manual.		
Rotor Speed:	385	
After speed is greater than 50, press ENTER to continue.		

5. Select Aircraft Condition screen. Displays the ground and flight regimes that are specified in the setup. Select Ground and press **[Enter]**.

Model 2020 ProBalancer Select Aircraft Condition		
<input type="checkbox"/>	Ground	
<input type="checkbox"/>	Hover	
<input type="checkbox"/>	80KTS	
<input type="checkbox"/>	140KTS	
<input type="checkbox"/>	UNE	
End Run		Chk Track

6. Acquiring Vibration Data. This screen is displayed during the vibration acquisition. When stable vibration readings are observed, press **[Enter]**.

Model 2020 ProBalancer Run: 1 Condition: Ground		
1 Vertical	Lateral	1
Current	Current	
RPM: 385	RPM: 385	
IPS: 0.54	IPS: 0.62	
Phase: 03:16	Phase: 05:55	
Average	Average	
RPM: 385	RPM: 385	
IPS: 0.51	IPS: 0.59	
Phase: 03:11	Phase: 06:00	
% Err: 0	% Err: 0	
0		0
Reset		

7. Review Data. This screen allows the user to view the vibration readings that were acquired during the regime. Press **[Enter]** to continue.

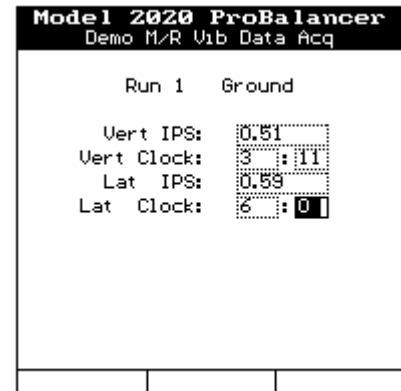

8. Review Data. This screen allows the user to view the vibration readings that were acquired during the regime. Press **[Enter]** to continue or **[F-3]** to take track data. Once track data is acquired continue to next flight regime as prompted by the balancer. Continue until all balance points and track readings are obtained.

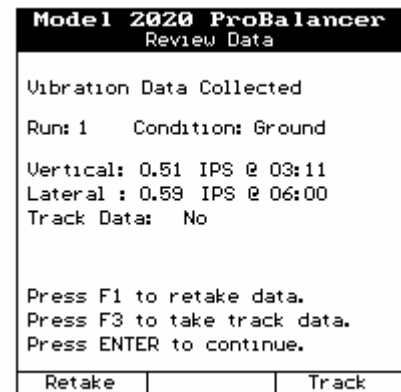

8. The "Track Screen" will appear prompting you to aim and fire the tracker. Aim the tracker at the tip of the rotor disk at the 12:00 position. Move tracker up and down until green LED's are illuminated. Press trigger one time and continue to hold tracker with green LED's illuminated. The amber LED will pulsate during the acquisition. When tracker acquisition is complete the amber LED will extinguish.

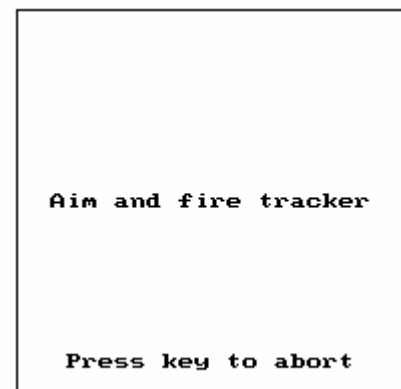

- The track data will now appear on the screen. The track split will be shown. If the number of packets recorded is less than 75% of the total, press **[Enter]** and then **[F-1]** to retake the track reading. After review press **[Enter]** to continue.

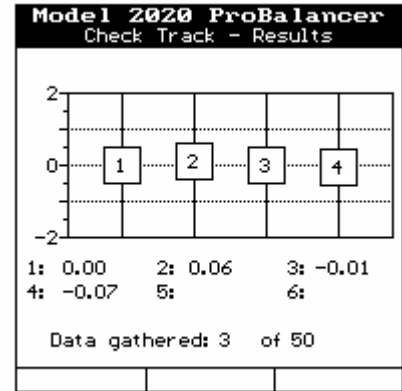

- The Review Data screen will reappear, press **[Enter]** to continue.

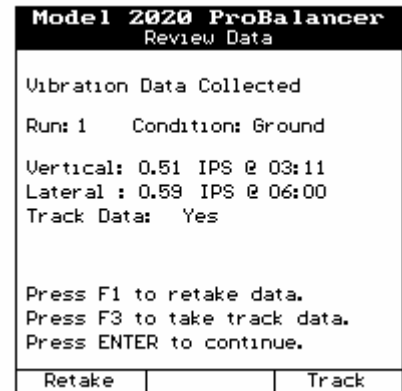

Note

At any time during a flight if the vibration levels are found to be too severe to continue, the user has the option to end-run and solve for the vibration data acquired to that point.

- Repeat sequence through all flight regimes. After all data is acquired press the “Adjust” **[F-2]** button, shut down the aircraft and review solution options.

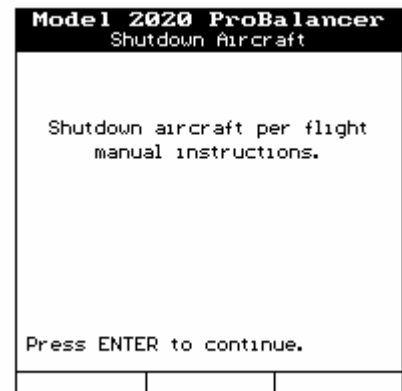
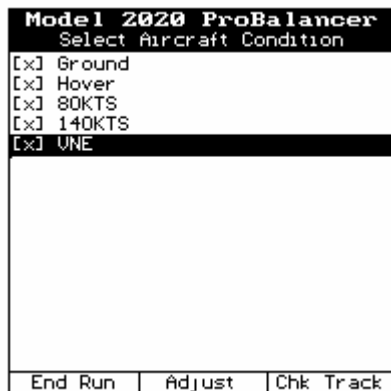

12. The analyzer will present all of the solutions possible from the data gathered. It is possible for the analyzer to give two adjustments that would adversely affect the other. The user is ultimately responsible for determining which adjustments to implement and which to discard. Make the desired adjustments to the rotor system as called for by analyzer and press **[Enter]**. The user will now be prompted to start the engine and continue with run #2.

Model 2020 ProBalancer		
M/R Sugg. and Inst. Adj		
Run 1		
Name: Lat: Ground,GMS		
Bld/Pos	Suggested	Installed

TARGET:	0.00	0.00
A	0.00	0.00
B	295.00	295.00
C	0.00	0.00
+Adj = WtAdd/SwFwd/BldUp/TabUp		
Inst=Sugg	Inst=None	Quit Job

Model 2020 ProBalancer		
M/R Sugg. and Inst. Adj		
Run 1		
Name: Trk:80KTS-UNE, TAB, Deg		
Bld/Pos	Suggested	Installed

TARGET:	0.00	0.00
A	-0.56	-0.56
B	0.01	0.01
C	-0.93	-0.93
+Adj = WtAdd/SwFwd/BldUp/TabUp		
Inst=Sugg	Inst=None	Quit Job

Note

It is important to remember that when installing or removing weights and recording their positions that the influence used for the next run will be updated by the result from the previous run's solution, therefore be as accurate as possible when recording adjustments made regardless whether the recommended solution is implemented. The only entries on this screen should reflect the actual solution implemented.



Application Note

Agusta A119 Koala

Main Rotor Balance

Part Number: 11-200-0116

AppNote Number: a-aga119-2020e-mr

This Application Note is provided for information only and does not supercede the requirements or guidelines set forth in the applicable engine or airframe maintenance manual. Technology for Energy Corporation assumes no obligation or liability, either express or implied, to the Purchaser arising out of the use of this procedure.

Copyright © 2001, TEC Aviation Division. All rights reserved. This document is to be printed and reproduced for personal use only.