



Application Note

Agusta 109E Power

Main Rotor Track and Balance

Part Number: 11-200-0194

AppNote Number: A-AG109E-4040-MR (Rev. 0, May 2005)

This Application Note is provided for information only and does not supersede the requirements or guidelines set forth in the applicable engine or airframe maintenance manual. Technology for Energy Corporation assumes no obligation or liability, either expressed or implied, to the Purchaser arising out of the use of this procedure.

Copyright © 2005, TEC Aviation Division. All rights reserved. This document is to be printed and reproduced for personal use only.



Application Note

| | |
|-------------------------|-------------------------------|
| Application Note Number | A-A109E-4040-MR |
| Revision | 0 (From Airframe Rev 7) |
| Function | Main Rotor Track and Balance |
| Airframe | Agusta 109E Power |
| Engine | N/A |
| E-Setup Number | a-ag109e-4040-mr.asf |
| ACES Systems Analyzer | Model 4040 |
| Boot/App Version | Boot 1.04/App 1.05p3 or later |
| Procedure | N/A |

Introduction

This Application Note covers the required equipment, equipment installation, analyzer setup, data acquisition and solution process for using the ACES Systems Model 4040 Viper Analyzer with the Main Rotor Performance Option to perform main rotor track and balance on the airframe listed above. General instructions for the use of the Model 4040 can be found in the Model 4040 User Manual #4040-OM-01 (P/N 75-900-4040) and Optical Tracker Operational Supplement #540-OM-1 (P/N 75-900-2021). All procedures for track and balance and all adjustments should be made in accordance with the Airframe Maintenance Manual.

A. Equipment Setup

Required Equipment: The following equipment is required to perform a Main Rotor Track and Balance:

| Item | Quantity | Description | Part Number |
|------|----------|---|--------------|
| 1. | 1 | Analyzer, Model 4040 | 10-100-4040 |
| 2. | 1 | Option, 4040 Main and Tail Rotor | 11-900-0005 |
| 3. | 2 | Sensor, Vibe, Accel, 991D-1 | 69-100-0075 |
| 4. | 1 | Cable, Sensor 991D-1, 25' | 10-320-0162 |
| 5. | 1 | Cable, Sensor 991D-1, 50' | 10-320-0163 |
| 6. | 1 | Sensor, Magnetic Passive Speed | 75-900-0187 |
| 7. | 2 | Mount, 1/4X28 Sensor, Vibe 1/4" Hole, S/Stl | 22-430-0035 |
| 8. | 1 | Tracker, Optical, Model 540-2 | 75-900-0542* |

| | | | |
|----|---|---------------------------------|-------------|
| 9. | 1 | Cable, Adapter, Magnetic Pickup | 10-320-0220 |
|----|---|---------------------------------|-------------|

*This listing shows the latest design parts. It is acceptable to perform this task using previous designs with the appropriate accessories. For compatibility issues, contact ACES Systems.

Miscellaneous Equipment

Tape or tie wraps to secure cables to airframe.

B. Equipment Installation

Note:

Interrupter and magnetic pickup should be permanently installed on swashplate. If not, install as described in Maintenance Manual.

1. Install Sensor Mount (Item 6) between the pilot's and copilot's seats and a second Sensor Mount (Item 6) to upper left nut of the pilot's inertia reel. Secure the first 991D-1 Vibration Sensor (Item 2) to the bracket so that it is perpendicular to the longitudinal axis of the aircraft with connector pointing to the right. Install second 991D-1 Vibration Sensor (Item 2) into bracket so that connector faces up. (Figure 1)
2. Install Sensor Cable (Item 3) to Vertical 991D-1 Sensor and connect to Channel A on the Model 4040 Analyzer.
3. Install Sensor Cable (Item 4) to Lateral 991D-1 Sensor and connect to Channel B on the Model 4040 Analyzer.
4. Connect Magnetic Pickup Adapter Cable (Item 8) to the signal socket located above and behind the pilot's head. Connect other end of cable to Tach 1 on the Model 4040 Analyzer.
5. Connect optical tracker (Item 8) to the Aux/Comm. port on the Model 4040 Analyzer. The blades will be numbered as in (Figure 2). This is the location of the main rotor head when the magnetic pickup and interrupter are aligned.

NOTE

Secure and route cables as not to interfere with any flight controls in the cockpit area.

Equipment Installation Diagram

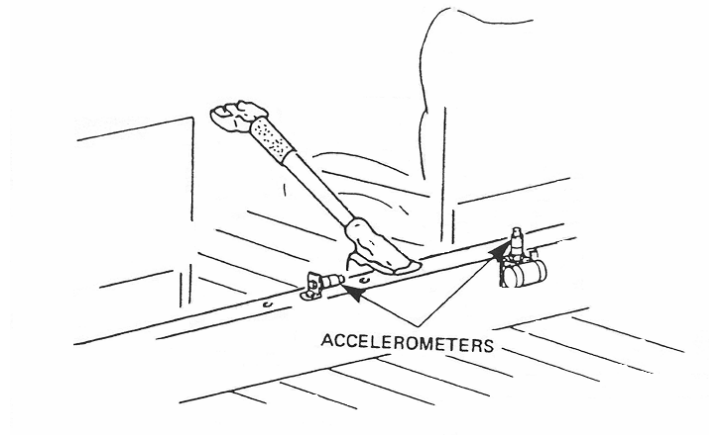

Figure 1

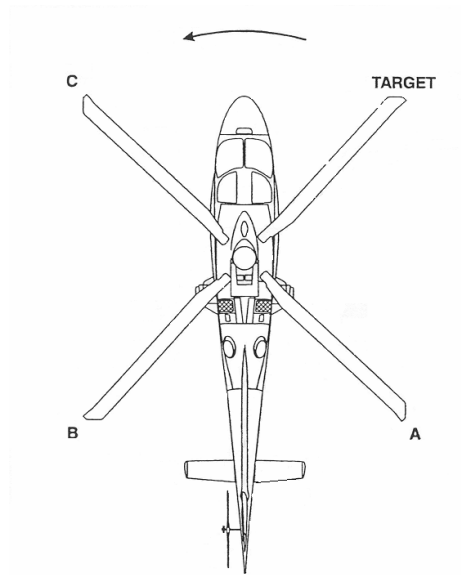
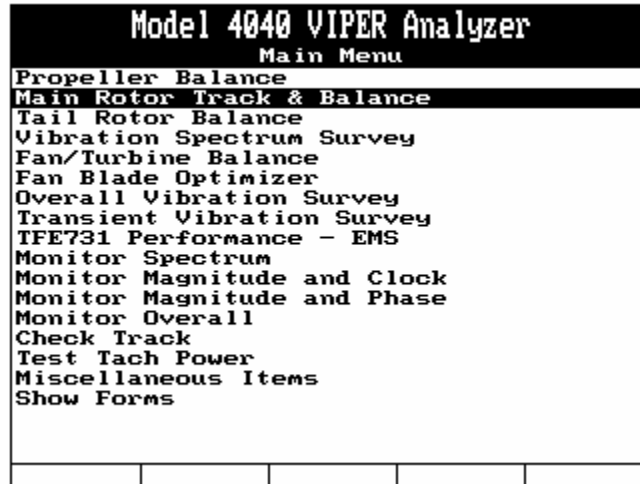

Figure 2



C. Analyzer Set Up

1. Insure the analyzer battery is charged prior to starting the job.
2. Turn the analyzer ON by pressing the [ON/OFF] key.
3. From the Main Menu shown below, select “Main Rotor Track & Balance” and press the [ENTER] key.



4. From the Main Rotor Track & Balance Menu shown below, select “Start Job” and press the [ENTER] key.

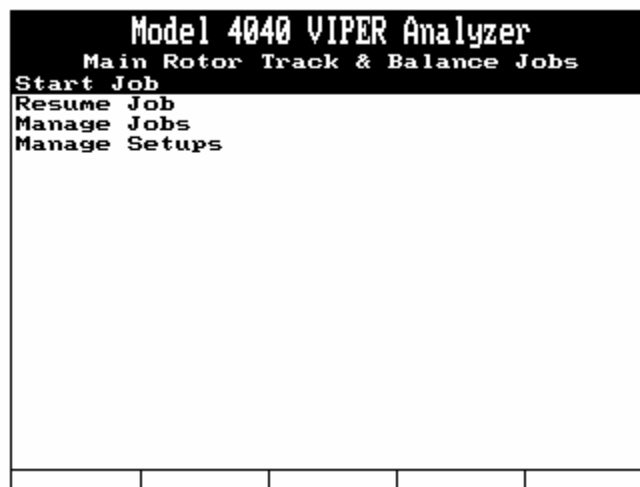

5. If the Agusta 109E Power is listed in the Setup List, select it using the [↓] key, press [ENTER] and go to Section D below. If the Agusta 109E Power is not in the Setup List, press the [F1], “New” key and go to Step 6 below.

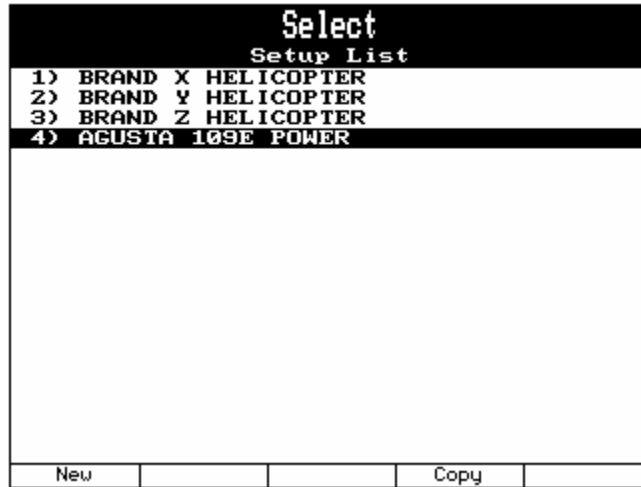

6. The “Main Rotor Setup” screen now appears. Enter the Main Rotor Setup as shown below. When completed press [ENTER].

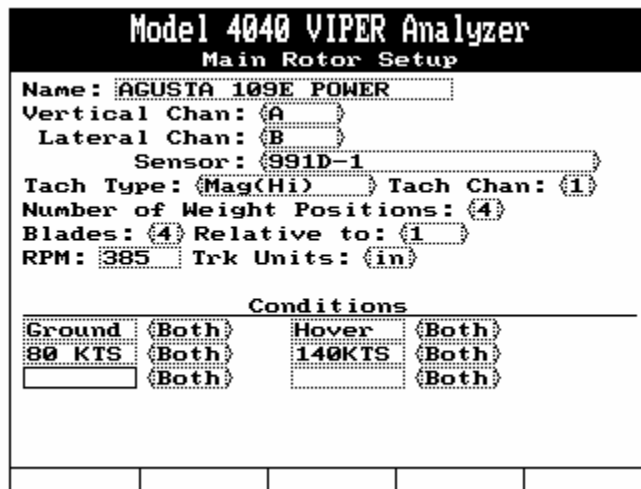

7. The “Tracking Setup” screen will be displayed next. Enter the values as shown in the illustration below. Press [ENTER] to continue.

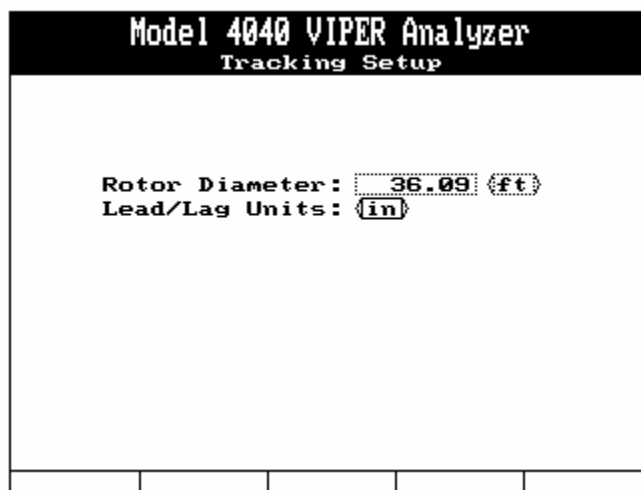

8. The “Main Rotor Conds. Setup” screen will appear next as displayed below. Enter the information as indicated in the illustration below. Press [ENTER] to continue.

```

Model 4040 VIPER Analyzer
Main Rotor Conds. Setup
Vert   Lat   Track
Chart  Chart  Adj.
Conds. ID    ID    ID
-----
Ground 0     1     1
Hover  0     0     1
80 KTS 0     0     2
140KTS 1     0     2

Limit  0.20  0.20  0.25

Enter ID, or 0 if no adjustment.
Different charts use different IDs.
    
```

9. The next screen to appear will be the “M/R Adj Symbol Setup” screen. The function of this screen is to determine the direction of movement for a positive (+) adjustment. In this application, a positive move indication means to ADD weight, sweep a blade FWD, and move the blade UP with both Pitch Change Link (BLADE) and Trim Tab (TAB). Enter the values as shown below. The final line is identified as “Soln:” this line will determine which solutions the analyzer will display after the completion of a run. “ALL” will present all available solutions and “MAX” will present the solution derived from the highest value over the limits set in Paragraph 8 above for each chart. When completed press [ENTER].Next, the balance charts will be entered into the analyzer.

```

Model 4040 VIPER Analyzer
M/R Adj Symbol & Soln Logic

Adjustment Positive Value Meaning
Weight:  (ADD)
Sweep:   (FWD)
Blade:   (UP)
TAB:     (UP)

Soln:    (ALL)
    
```

10. The first balance chart to define will be the “Vert: 140KTS” chart. Enter the information as presented below. Press [ENTER] to continue.



```

Model 4040 VIPER Analyzer
Main Rotor Chart Setup
Name: Vert 140KTS
Type: Regular Sweep Only: No
No Adjustment Bld/Pos: None
Max ICF Update: 150 % R(°): 45
Adj Unit: DEG Adj/IPS: 8.000
Bld/Pos MoveLine Bld/Pos
TARGET 5 : 30
A 2 : 30
B
C
Bld/Pos: in CW or CCW order

+Adj = WtAdd/SwFwd/B1Up/TabUp

Help
    
```

11. The second chart to define will be the “Lat: Ground” chart. Enter the information as shown below and press [ENTER] to continue.

```

Model 4040 VIPER Analyzer
Main Rotor Chart Setup
Name: Lat Ground
Type: Regular Sweep Only: No
No Adjustment Bld/Pos: None
Max ICF Update: 150 % R(°): 45
Adj Unit: GMS Adj/IPS: 1200.000
Bld/Pos MoveLine Bld/Pos
TARGET 2 : 50
A 11 : 50
B
C
Bld/Pos: in CW or CCW order

+Adj = WtAdd/SwFwd/B1Up/TabUp

Help
    
```

12. The Ground – Hover “Tracking Influence Setup” screen data will be entered as shown below. When completed, press [ENTER] to continue.

```

Model 4040 VIPER Analyzer
Tracking Influence Setup

| Conds        | Adj Name | Unit | Adj/in | Max Upd% |
|--------------|----------|------|--------|----------|
| Ground-Hover | PCL      | FLI  | 4.000  | 200      |

No Adjustment Bld/Pos: None
Blade Names:
1. TARGET
2. A
3. B
4. C

+Adj = WtAdd/SwFwd/B1Up/TabUp

Help
    
```

- The 80 KTS – 140KTS “Tracking Influence Setup” screen data will be entered as shown below. When completed, press [ENTER] to continue.

```

Model 4040 VIPER Analyzer
Tracking Influence Setup

Adj      Max
Conds    Name Unit Adj/in Upd%
80 KTS-140KT TAB DEG 1.000 200
No Adjustment Bld/Pos: (None)
Blade Names:
1. TARGET
2. A
3. B
4. C

+Adj = WtAdd/SwFwd/BlUp/TabUp
    
```

D. Data Acquisition

- The “Job Identification” will be displayed, as shown below. Use the analyzer keypad to enter a customer name in the “Name:” field. The analyzer will maintain a list of customer names as new names are entered. If names have been previously entered into this analyzer, you may press the [F1] “Names” key and select a customers name from the provided list. Press the [↓] key to move to the next field and use the analyzer keypad to enter the optional aircraft registration and aircraft total time as required. When all fields are complete, press the [ENTER] key to accept and continue.

```

Model 4040 VIPER Analyzer
Job Identification

Name : CUSTOMER NAME
A/C Registration: N1234
A/C Total Time: 123.4

Press ENTER to continue

Names
    
```

- The next screen to be displayed is the “Tracking Selections”, as shown below. Enter the data as displayed. When all fields are complete, press the [ENTER] key to continue.

| Model 4040 VIPER Analyzer | | | | |
|---|--|--|--|--|
| Tracking Selections | | | | |
| Track Device: <input type="text" value="Tracker"/> | | | | |
| - For Optical Tracking Only - | | | | |
| Number of Rotations: <input type="text" value="50"/> | | | | |
| Inches To Blade Tip: <input type="text" value="144"/> | | | | |
| | | | | |

- The next screen to be displayed will be the “Main Rotor Equipment Setup” screen as illustrated below. This screen gives instructions on installing sensors and cables. Press [ENTER] to continue to the next screen.

| Model 4040 VIPER Analyzer | | | | |
|--|--|--|--|--|
| Main Rotor Equipment Setup | | | | |
| Install the speed sensor and connect to TACH channel 1 | | | | |
| Install vertical vibration sensor to vibration channel A | | | | |
| Install lateral vibration sensor to vibration channel B | | | | |
| Tach power is Off | | | | |
| Tach On | | | | |

- The “Start Aircraft” screen will be displayed with instructions to “Start Aircraft per Flight Manual”. When the aircraft is started and normal operating conditions have been established, press the [ENTER] key to continue.

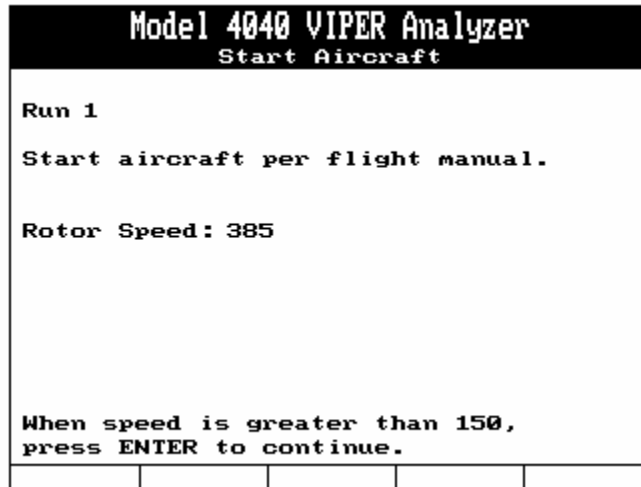

- 5. The analyzer will display the “Select Aircraft Condition” screen as displayed below. Select the condition that you want to gather data for using the [↑] [↓] arrows and press [ENTER]. Pressing [F5] “Chk Track” will allow you to view the track picture but will not save the reading as part of the highlighted condition. See paragraph 7 below to record the track picture with the condition’s vibration readings.



Note

At any time during a flight if the vibration levels are found to be too severe to continue, the user has the option to end run and solve for the vibration data acquired to that point.



- After pressing [ENTER] the “Run: 1 Condition: Ground” screen will be displayed as shown in the example below. Chapter 20 of the Model 4040 User’s Manual gives detailed instructions on how to read the converging scale if you are not familiar with it. Operate the aircraft in the configuration for the selected condition and allow the analyzer to collect data. The “Err:” indication at the bottom of the text portion of the screen should be as steady as possible with very little change before you press [ENTER] to stop acquisition. If the “Err” is not “0”, this is not an indication of failure or fault, only that the vibration averaging errors cannot be resolved below the displayed level. This “Err” value will typically be higher as the balancing process reduces the vibration amplitude.

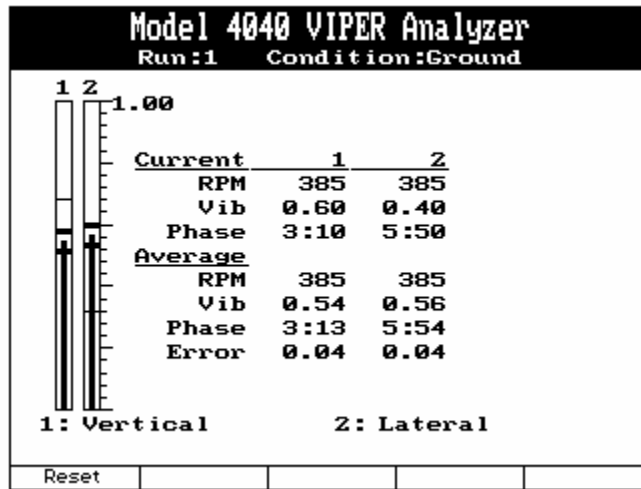

- The “Review Data” screen will be displayed as shown in the example below. These are the amplitude and clock angle readings for the condition. You may retake the data by pressing the [F1] “Retake” function key as indicated at the bottom of the screen. When satisfied with the acquired data as displayed, press the [ENTER] key to accept the data with “No” track information and continue. To record the track picture for the condition, press [F5] “Track” and proceed to paragraph 8.

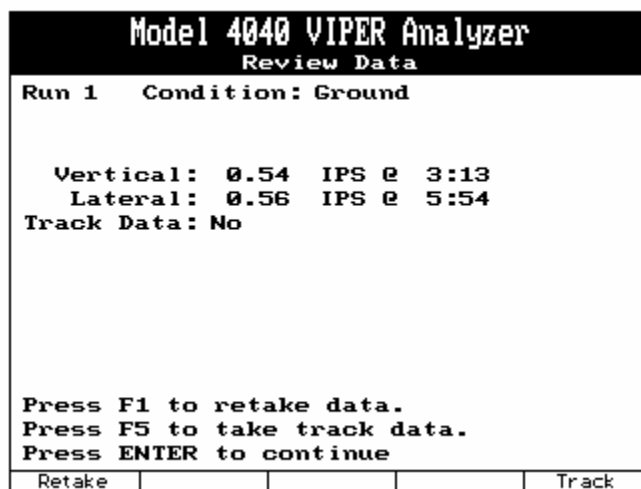

8. The “Aim and fire tracker” screen will be displayed as shown in the example below. To aim the tracker, raise the tracker smoothly towards the rotating rotor disk while observing the LEDs on the back of the tracker.

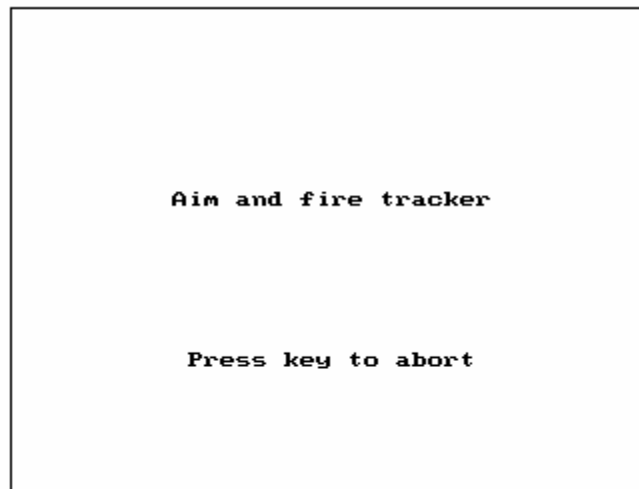

- a. Raise the tracker until the three green LED lights are illuminated.
 - b. Raise the tracker further to verify the upper set of three red LEDs illuminate. Illumination of the three upper LEDs verifies there is enough contrast to operate the tracker. If the upper set of red LEDs does not illuminate, there is not enough contrast for the tracker to operate properly.
 - c. If sufficient contrast is verified, slowly lower the tracker to a point where the center green LED is illuminated. Hold the tracker steady in this position.
 - d. To activate the tracker, press and release the trigger one time. It is not necessary to hold the trigger down. Continue to hold the tracker steady (green lights illuminated) while acquiring data.
 - e. When the amber light extinguishes, data acquisition is complete and you may lower the tracker.
9. The track picture will be displayed on the “Check Track – Results” screen. Lead/lag readings will be displayed at the top of the screen. A negative number (-) indicates a “Lead” condition as this blade is the indicated measurement less than the average interval. A positive number (no sign) indicates a “Lag” condition as this blade is the indicated measurement more than the average interval. Readings will be displayed graphically in the center of the screen. Lead readings will be indicated to the Left of the average interval marking vertical line. Lag readings will be displayed to the Right of the line. Track readings will be displayed above or below the line relative to the average of all blades or in relation to the blade specified in the setup, Paragraph C.6. The bottom of the screen will give a numeric reading of the blade track elevation. The bottom line will display the number of data samples gathered. If the total number of data samples gathered is less than 75% of the total number of samples requested (the last value on the line) the results are questionable and should be retaken. When you are happy with the quality of the data, press **[ENTER]** to continue.

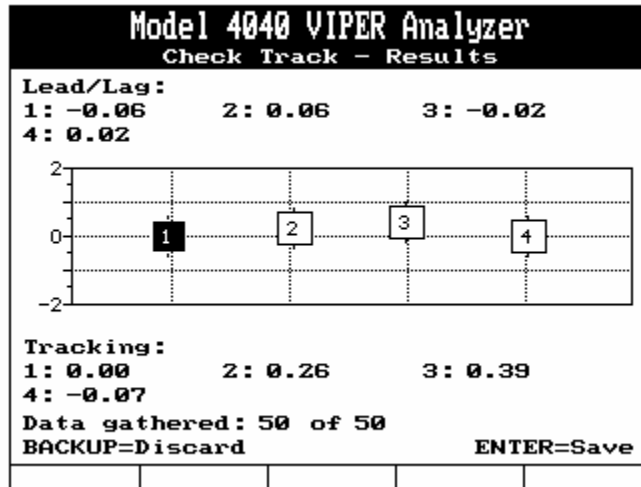

10. The “Review Data” screen will reappear as shown in the example below. This time the “Track Data” line will read “Yes” indicating that track data has been taken and stored in this condition. You may retake vibration data by pressing the [F1] “Retake” function key as indicated at the bottom of the screen. You may retake the track data by pressing the [F5] “Track” key. If you are satisfied with the current measurements, press [ENTER] to continue.

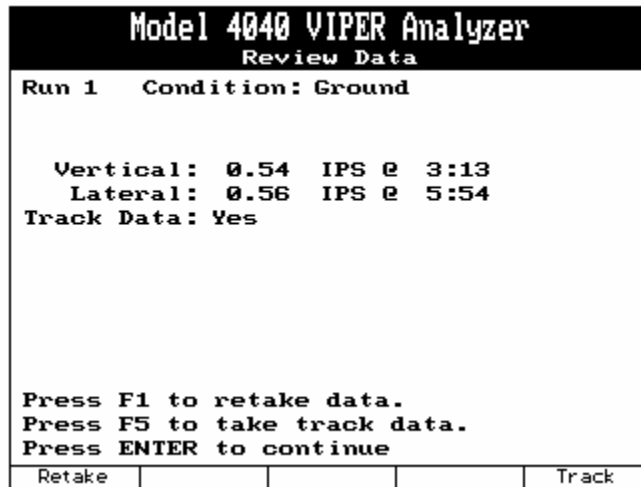

11. The “Select Aircraft Condition” screen will reappear as shown in the example below. This time any condition that has stored vibration and/or track data will have an [x] preceding the condition name. Repeat sequence through all flight regimes. You can choose to “End Run” at any time by pressing the [F1] “End Run” key. This sequence will allow you to review all previous measurements before proceeding to the suggested solutions. If a condition has recorded a vibration or track reading that is in excess of the limits defined in paragraph C.8 above, the word “Adjust” will appear above the [F2] key. Pressing [F2] “Adjust” will bypass the review process and move directly to the suggested solution screens. In either case you will be taken to paragraph 12 below.

| Model 4040 VIPER Analyzer | | | | |
|---------------------------|--------|--|--|-------|
| Select Aircraft Condition | | | | |
| [x] | Ground | | | |
| [x] | Hover | | | |
| [x] | 80 KTS | | | |
| [x] | 140KTS | | | |
| End Run | Adjust | | | Track |

NOTE

The [F1] “End Run” and [F2] “Adjust” keys are the only ways to exit this screen. Pressing [ENTER] will restart the data collection process for the highlighted condition.

- The analyzer will display the “Shut Down Aircraft” screen. When this process is complete, press the [F5] “Continue” key to review the data or view the suggested solutions.

| Model 4040 VIPER Analyzer | | | | |
|--|--|--|--|----------|
| Shut Down Aircraft | | | | |
| Shut Down Aircraft per flight manual instructions | | | | |
| | | | | Continue |

NOTE

It is important to remember that when installing or removing weights and recording their positions the influence used for the next run will be updated by the result from the previous run’s solution. Therefore, be as accurate as possible when recording adjustments made regardless whether the recommended solution is implemented. The only entries on these screens should reflect the actual solution implemented.

- The analyzer will present all of the solutions possible from the data gathered. It is possible for the analyzer to give two adjustments that would adversely affect the other. The user is ultimately responsible for determining which adjustments to implement and which to discard. If a suggested correction is determined unnecessary, use “Inst=None” [F2] to eliminate data

in the “Installed” column. Make the desired adjustments to the rotor system as called for by analyzer and press [ENTER]. The user will now be prompted to start the engine and continue with run #2.

E. Solution Examples

This section contains samples of the solution screens presented by the analyzer. The corrections are examples only and do not reflect actual aircraft data.

CAUTION

At no point should a correction be made that contradicts information in the maintenance manual.

NOTE

Solutions will only be presented for readings that exceed the limits set in Paragraph C.8 above. All solutions may not appear after every run. It is necessary to add the closest measurable amount of correction and record the actual correction in the “Installed” column.

1. The first possible solution screen is the “Vert: 140KTS, DEG” solution. This screen will suggest Trim Tab adjustments based on the measured vertical vibration readings.

In the example below, it is suggested to adjust the TARGET trim tab up 1.58 degrees (DEG) and the A trim tab up 4.02 DEG. The closest possible adjustment was 1.50 degrees on the TARGET Blade and 4.00 DEG on the A Blade. This adjustment was made and entered into the analyzer.

| Model 4040 VIPER Analyzer | | | |
|-------------------------------------|-----------|-----------|----------|
| M/R Suggested/Installed Adjustments | | | |
| Run 1 | | | |
| Name: Vert 140KTS, DEG | | | |
| Bld/Pos | Suggested | Installed | |
| TARGET | 1.58 | 1.50 | |
| A | 4.02 | 4.00 | |
| B | 0.00 | 0.00 | |
| C | 0.00 | 0.00 | |
| +Adj = WtAdd/SwFwd/BIUp/TabUp | | | |
| Inst=Sugg | Inst=None | | Quit Job |

2. The second possible solution screen available is from the “Lat: Ground, GMS” chart. This screen suggests the corrections to make to improve Lateral vibration readings. In the example below, the suggestion is to add 247.78 grams (GMS) to the TARGET Blade and add 45.92 GMS to the C Blade. The closest measurable value was the addition of 250.00 GMS to the TARGET Blade and the addition of 46.00 GMS to the C Blade. This move was made and entered into the analyzer.

| Model 4040 VIPER Analyzer | | | |
|-------------------------------------|-----------|-----------|----------|
| M/R Suggested/Installed Adjustments | | | |
| Run 1 | | | |
| Name: Lat Ground, GMS | | | |
| Bld/Pos | Suggested | Installed | |
| TARGET | 247.78 | 250.00 | |
| A | 0.00 | 0.00 | |
| B | 0.00 | 0.00 | |
| C | 45.92 | 46.00 | |
| +Adj = WtAdd/SwFwd/BlUp/TabUp | | | |
| Inst=Sugg | Inst=None | | Quit Job |

- The next possible solution comes from the “Trk: Ground – Hover, PCL, Flt” chart. The analyzer will present a suggested correction to the Pitch Change Links (PCL) in flats (Flt) to bring the track within limits. In this case, the analyzer will present solutions to work toward the TARGET Blade as defined in Paragraph C.6 the line reading “Relative to”. Adjusting the A Blade DOWN by (-) 0.64 Flt, bringing the B Blade down by (-) 0.76 Flt, and bringing the C Blade up by 0.27 Flt should correct the track split. The closest measurable adjustments were determined to be to adjust the A Blade down (-) 0.50 Flt, the B Blade down (-) 1.00 Flt, and no adjustment was made to the C Blade. The adjustments are made and entered into the analyzer. To enter a negative (-) number press the [SPACE] key once.

| Model 4040 VIPER Analyzer | | | |
|-------------------------------------|-----------|-----------|----------|
| M/R Suggested/Installed Adjustments | | | |
| Run 1 | | | |
| Name: Trk Ground-Hover, PCL, F | | | |
| Bld/Pos | Suggested | Installed | |
| TARGET | 0.00 | 0.00 | |
| A | -0.64 | -0.50 | |
| B | -0.76 | -1.00 | |
| C | 0.27 | 0.00 | |
| +Adj = WtAdd/SwFwd/BlUp/TabUp | | | |
| Inst=Sugg | Inst=None | | Quit Job |

4. The final possible solution comes from the “Trk 80 KTS – 140 KTS, TAB, Deg” chart. The analyzer will present a suggested correction to the Trim Tabs (TAB) in Degrees (Deg) to bring the track within limits. In this case, the analyzer will present solutions to work toward the TARGET Blade as defined in Paragraph C.6 the line reading “Relative to”. Adjusting the A Blade DOWN by (-) 0.25 Deg should correct the track split. The closest measurable adjustments were determined to be to adjust the A Blade down (-) 0.25 Deg. The adjustment is made and entered into the analyzer. To enter a negative (-) number press the [SPACE] key once. Keep in mind adjustments from this screen may contradict adjustments to the trim tabs from the “Vert: 140KTS, DEG” chart. You will be responsible for choosing the solution path that meets your needs.

| Model 4040 VIPER Analyzer | | |
|-------------------------------------|-----------|-----------|
| M/R Suggested/Installed Adjustments | | |
| Run 1 | | |
| Name: Trk 80 KTS-140KTS, TAB, | | |
| Bld/Pos | Suggested | Installed |
| TARGET | 0.00 | 0.00 |
| A | -0.25 | -0.25 |
| B | 0.00 | 0.00 |
| C | 0.00 | 0.00 |
| +Adj = WtAdd/SwFwd/BIUp/TabUp | | |
| Inst=Sugg | Inst=None | Quit Job |

F. Quit Job

1. Repeat steps D.4 through D.13 applying the solutions as necessary. If all measurements in all conditions are below the limits set in Paragraph C.8 above, the message below will appear. Pressing the [BACKUP] key will allow you to return to review the measurements from all runs. Pressing the [ENTER] key will allow you to take additional readings if you choose. Pressing [F5] “Quit Job” will mark the job as complete.

| Model 4040 VIPER Analyzer | | |
|-------------------------------|--|----------|
| M/R Track & Balance | | |
| No solutions are recommended. | | |
| Press BACKUP to view data. | | |
| Press F5 to quit job. | | |
| Press ENTER for next Run. | | |
| | | Quit Job |